



Designation: **D6940—18 D6940/D6940M – 20**

Standard Practice for Measuring Sifting Segregation Tendencies of Bulk Solids¹

This standard is issued under the fixed designation ~~D6940~~; **D6940/D6940M**; the number immediately following the designation indicates the year of original adoption or, in the case of revision, the year of last revision. A number in parentheses indicates the year of last reappraisal. A superscript epsilon (ϵ) indicates an editorial change since the last revision or reappraisal.

1. Scope*

1.1 This practice covers an apparatus and procedure for simulating the segregation tendencies of bulk solids by means of the sifting mechanism.

1.2 Temperature- and humidity-sensitive bulk solids may need to be tested at different temperatures and moisture contents, as would happen in an industrial environment.

1.3 The maximum particle size should be limited to 3 ~~mm~~, **mm** [$1/8$ in.], to reduce the likelihood of binding the slide gate.

1.4 This standard is not applicable to all bulk solids and segregation mechanisms: while sifting is a common segregation mechanism experienced by many bulk solids, other segregation mechanisms not evaluated by this standard might induce segregation in practice. Practice **D6941** covers another common mechanism: fluidization.

1.5 The extent to which segregation will occur in an industrial situation is not only a function of the bulk solid and its tendency to segregate, but also the handling equipment (for example, bin design), process (for example, transfer rates), and environment.

1.6 Units—The values stated in either SI units or inch-pound units are to be regarded as standard. ~~No other units of measurement are included in this standard.~~ The values stated in each system may not be exact equivalents; therefore, each system shall be used independently of the other. Combining values from the two systems may result in nonconformance with the standard.

1.7 All observed and calculated values shall conform to the guidelines for significant digits and rounding established in Practice **D6026**.

1.8 This practice offers a set of instructions for performing one or more specific operations. This document cannot replace education or experience and should be used in conjunction with professional judgment. Not all aspects of this practice may be applicable in all circumstances. This ASTM standard is not intended to represent or replace the standard of care by which the adequacy of a given professional service must be judged, nor should this document be applied without consideration of a project's many unique aspects. The word "Standard" in the title of this document means only that the document has been approved through the ASTM consensus process.

1.9 *This standard does not purport to address all of the safety concerns, if any, associated with its use. It is the responsibility of the user of this standard to establish appropriate safety, health, and environmental practices and determine the applicability of regulatory limitations prior to use.*

1.10 *This international standard was developed in accordance with internationally recognized principles on standardization established in the Decision on Principles for the Development of International Standards, Guides and Recommendations issued by the World Trade Organization Technical Barriers to Trade (TBT) Committee.*

2. Referenced Documents

2.1 *ASTM Standards:*²

D653 Terminology Relating to Soil, Rock, and Contained Fluids

D2216 Test Methods for Laboratory Determination of Water (Moisture) Content of Soil and Rock by Mass

D3740 Practice for Minimum Requirements for Agencies Engaged in Testing and/or Inspection of Soil and Rock as Used in Engineering Design and Construction

D6026 Practice for Using Significant Digits in Geotechnical Data

¹ This practice is under the jurisdiction of ASTM Committee **D18** on Soil and Rock and is the direct responsibility of Subcommittee **D18.24** on Characterization and Handling of Powders and Bulk Solids.

Current edition approved ~~June 1, 2018~~ Jan. 1, 2020. Published ~~July 2018~~ January 2020. Originally approved in 2003. Last previous edition approved in 2010 as **D6940—10—18**. DOI: ~~10.1520/D6940-18~~ 10.1520/D6940_D6940M-20.

² For referenced ASTM standards, visit the ASTM website, www.astm.org, or contact ASTM Customer Service at service@astm.org. For *Annual Book of ASTM Standards* volume information, refer to the standard's Document Summary page on the ASTM website.

*A Summary of Changes section appears at the end of this standard

D6941 Practice for Measuring Fluidization Segregation Tendencies of Powders

3. Terminology

3.1 Definitions:

3.1.1 For common definitions of terms in this standard, refer to Terminology **D653**.

3.1 Definitions:

3.1.1 For common definitions of terms in this standard, refer to Terminology **D653**.

3.1.2 funnel flow pattern, *n*—in storing, handling and processing bulk solids using industrial equipment, a flow sequence in a bin or hopper characterized by having some particles moving while other particles are stagnant during discharge.

3.1.3 mass flow pattern, *n*—in storing, handling and processing bulk solids using industrial equipment, a flow sequence in a bin or hopper characterized by having all particles moving when discharge occurs.

3.1.4 sifting segregation, *n*—in storing, handling and processing bulk solids using industrial equipment, a mechanism in which finer particles preferentially percolate into a zone within the bulk solid.

4. Summary of Practice

4.1 A representative sample of a bulk solid is placed in the upper hopper of the apparatus.

4.2 The bulk solid is discharged to form a pile within the lower hopper, allowing segregation to take place.

4.3 The segregated material is discharged in a funnel flow pattern intended to recover zones of segregated material in a known sequence. Specimens are collected from the discharge stream.

4.4 The specimens are then available to be tested for differences relevant to the application, for example, particle size or chemical assay.

5. Significance and Use

5.1 Sifting segregation can cause horizontal segregation (for example, center-to-periphery) within bins used to hold and transport bulk solids. This can affect final product quality or subsequent processes in industrial applications.

5.2 By measuring a bulk solid's segregation tendency, one can compare results to other bulk solids with known history, or determine if the given bulk solid may have a tendency to segregate in a given process.

5.3 Sifting, which is a process by which smaller particles move through a matrix of larger ones, is a common method of segregation. Four conditions must exist for sifting to occur:

5.3.1 *A Difference in Particle Size between the Individual Components*—This ratio can be as low as 1.3 to 1. In general, the larger the ratio of particle sizes, the greater the tendency for particles to segregate by sifting.

5.3.2 *A Sufficiently Large Mean Particle Size*—Sifting segregation can occur with a mean particle size in the 50 µm range and can become a dominant segregation mechanism if the mean particle size is above 100 µm.

5.3.3 *Sufficiently Free Flowing Material*—This allows the smaller particles to sift through the matrix of larger particles. With cohesive materials, the fine particles are bound to one another and do not enter the voids among the coarse particles.

5.3.4 *Interparticle Motion*—This can be caused during formation of a pile, by vibration, or by a velocity gradient across the flowing material.

5.4 All four of these conditions must exist for sifting segregation to occur. If any one of these conditions does not exist, the material will not segregate by this mechanism.

NOTE 1—The quality of the result produced by this practice is dependent on the competence of the personnel performing it, and the suitability of the equipment and facilities used. Agencies that meet the criteria of Practice **D3740** are generally considered capable of competent and objective testing/sampling/inspection/etc. Users of this practice are cautioned that compliance with Practice **D3740** does not in itself assure reliable results. Reliable results depend on many factors; Practice **D3740** provides a means of evaluating some of those factors.

Practice **D3740** was developed for agencies engaged in the testing and/or inspection of soil and rock. As such it is not totally applicable to agencies performing this practice. However, users of this practice should recognize that the framework of Practice **D3740** is appropriate for evaluating the quality of an agency performing this practice. Currently there is no known qualifying national authority that inspects agencies that perform this practice.

6. Apparatus

6.1 The apparatus is shown in **Fig. 1**, and all critical dimensions are specified in **Fig. 2**. The apparatus consists of the following:

6.2 An upper hopper assembly consisting of an inner hopper seated within an outer hopper. This outer hopper-hopper, which provides support for the inner hopper, and has a hopper has an attached slide gate to start/stop material flow-flow and a guide cylinder to direct discharging particles to the lower hopper. The outer hopper also has support legs, which mate to the lower hopper assembly.

6.2.1 The inner hopper has a steep conical section made of metal or plastic and is designed to sit within the upper outer hopper and to provide mass flow for most bulk solids.

6.2.2 The outer hopper has a conical section made of metal or plastic and is designed to provide funnel flow for most bulk solids.

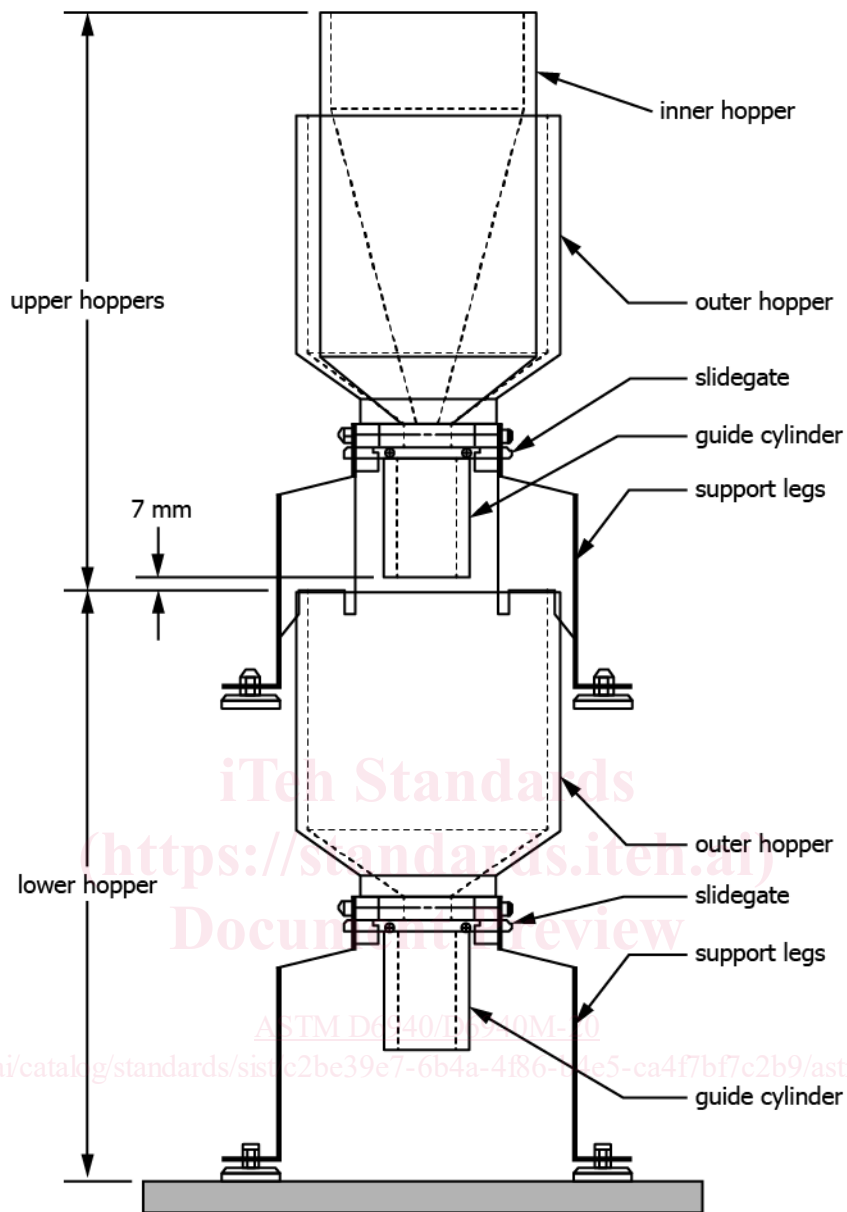

FIG. 1 Apparatus

6.2.2.1 Transparent plastic should be used to construct the inner and outer hoppers when observations of particle flow are desirable.

6.2.2.2 The slide gate, when open, shall have an opening size matching the opening size of the bottom of the outer hopper.

NOTE 2—Although only the inner hopper is used to contain the bulk solid being tested, placing this hopper inside the outer hopper provides a means to locate and support it, as well as a means to fill and empty the hopper (by using the slide gate). In addition, this outer hopper can be used for alternate test procedures that involve recycling material to and from a hopper of similar type. In this case a second inner hopper is also required.

6.3 A lower hopper assembly consisting of a second outer hopper. This outer hopper provides support for the upper hopper assembly, has an attached slide gate to start/stop material flow, and a guide cylinder for dispensing material into collecting cups. The outer hopper also has support legs to support the entire segregation tester.

6.3.1 The outer hopper has a conical section made of metal or plastic and is designed to provide funnel flow for most bulk solids.

6.3.2 Transparent plastic should be used to construct the outer hopper when observations of particle flow are desirable.

6.4 A collecting cup with a minimum capacity of 55 mL, mL [3.4 in.³], to collect specimens as they discharge from the lower hopper. The collecting cups must fit within the apparatus.

7. Procedure

7.1 Clean the apparatus and allow all parts to dry.