



Designation: **F496 – 14a F496 – 20**

# Standard Specification for In-Service Care of Insulating Gloves and Sleeves<sup>1</sup>

This standard is issued under the fixed designation F496; the number immediately following the designation indicates the year of original adoption or, in the case of revision, the year of last revision. A number in parentheses indicates the year of last reapproval. A superscript epsilon ( $\epsilon$ ) indicates an editorial change since the last revision or reapproval.

## 1. Scope

1.1 This specification covers the in-service care, inspection, testing, and use voltage of insulating gloves and sleeves for protection from electrical shock.

1.2 The values stated in SI units are to be regarded as the standard. See IEEE/ASTM SI-10.

1.3 The following safety hazards caveat pertains only to the test method portion, Sections 6 and 7, of this specification. *This standard does not purport to address all of the safety concerns, if any, associated with its use. It is the responsibility of the user of this standard to establish appropriate safety, health, and environmental practices and determine the applicability of regulatory limitations prior to use.* For a specific warning statement, see 7.2.

1.4 *This international standard was developed in accordance with internationally recognized principles on standardization established in the Decision on Principles for the Development of International Standards, Guides and Recommendations issued by the World Trade Organization Technical Barriers to Trade (TBT) Committee.*

## 2. Referenced Documents

2.1 *ASTM Standards:*<sup>2</sup>

[D120 Specification for Rubber Insulating Gloves](#)

[D1051 Specification for Rubber Insulating Sleeves](#)

[D2865 Practice for Calibration of Standards and Equipment for Electrical Insulating Materials Testing](#)

[F696 Specification for Leather Protectors for Rubber Insulating Gloves and Mittens](#)

[F819 Terminology Relating to Electrical Protective Equipment for Workers](#)

[F1236 Guide for Visual Inspection of Electrical Protective Rubber Products](#)

2.2 *ANSI Standards:*

[C 39.5 Safety Requirements for Electrical and Electronic Measuring and Controlling Instrumentation](#)<sup>3</sup>

[IEEE/ASTM SI-10 Standard for Use of the International System of Units \(SI\): The Modern Metric System](#)<sup>2</sup>

## 3. Significance and Use

3.1 Compliance with this specification should continue to provide personnel with insulating gloves and sleeves of known and acceptable quality after initial acceptance in accordance with Specifications [D120](#) and [D1051](#). The specifications herein are to be considered as minimum requirements.

3.2 A margin of safety shall be provided between the maximum use voltage and the voltage at which the gloves and sleeves are retested. The relationship between retest voltage and maximum use voltage at which the gloves and sleeves shall be used is shown in [Table 1](#).

3.2.1 When work is not being performed on energized conductors or equipment, or both, any contact with energized conductors or equipment, or both, would be limited to the phase-to-ground potential. If gloves are the only protection used in such operations, the phase-to-ground voltage to which the gloves may be exposed shall be limited to the maximum use voltage of that class glove as listed in [Table 1](#).

<sup>1</sup> This specification is under the jurisdiction of ASTM Committee [F18](#) on Electrical Protective Equipment for Workers and is the direct responsibility of Subcommittee [F18.15](#) on Worker Personal Equipment.

Current edition approved Nov. 1, 2014; Jan. 1, 2020. Published December 2014; February 2020. Originally approved in 1977. Last previous edition approved in 2014 as [F496 – 14](#); [F496 – 14a](#). DOI: [10.1520/F0496-14A](#); [10.1520/F0496-20](#).

<sup>2</sup> For referenced ASTM standards, visit the ASTM website, [www.astm.org](#), or contact ASTM Customer Service at [service@astm.org](#). For *Annual Book of ASTM Standards* volume information, refer to the standard's Document Summary page on the ASTM website.

<sup>3</sup> Available from American National Standards Institute (ANSI), 25 W. 43rd St., 4th Floor, New York, NY 10036, [http://www.ansi.org](#).

**TABLE 1 Voltage Requirements**

Class Designation of Glove or Sleeve	Maximum AC Use Voltage rms, V	AC Retest Voltage rms, V	Maximum DC Use Voltage avg, V	DC Retest Voltage avg, V
00	500	2 500	750	10 000
0	1 000	5 000	1 500	20 000
1	7 500	10 000	11 250	40 000
2	17 000	20 000	25 500	50 000
3	26 500	30 000	39 750	60 000
4	36 000	40 000	54 000	70 000

3.3 The user of these types of protective equipment shall be knowledgeable of and instructed in the correct and safe inspection and use of such equipment.

#### 4. Terminology

##### 4.1 Definitions:

4.1.1 *ozone*—a very active form of oxygen that may be produced by corona, arcing, or ultraviolet rays.

4.1.2 For definitions of other terms, refer to Terminology **F819**.

#### 5. Classification

5.1 Gloves and sleeves covered under this specification are designated as Type I or Type II; Class 00, Class 0, Class 1, Class 2, Class 3, or Class 4.

5.1.1 *Type I*, nonresistant to ozone, made from a high-grade *cis*-1,4-polyisoprene rubber compound of natural or synthetic origin, properly vulcanized.

5.1.2 *Type II*, ozone resistant, made of any elastomer or combination of elastomeric compounds.

5.1.3 The electrical properties correspond to those shown in **Table 1**. The class designations are those specified in Specifications **D120** and **D1051**.

#### 6. Inspection and Testing at an Electrical Testing Facility

6.1 The recommended sequence of inspection and testing of gloves and sleeves at an electrical testing facility is:

6.1.1 Check-in, washing, and preliminary inspection,

6.1.2 Repair,

6.1.3 Electrical test,

6.1.4 Drying,

6.1.5 Final inspection,

6.1.6 Record-keeping and marking, and

6.1.7 Powdering, pairing, and packing for storage or shipment.

6.2 When gloves and sleeves are received at an electrical test facility, they should be checked in as soon as practicable to eliminate any folds, creases, and improper storage.

6.3 The gloves and sleeves shall be washed with a mild soap or mild detergent and water. After washing, the gloves and sleeves shall be thoroughly rinsed with water to remove all soap or detergent and dried. Mild household type chloride bleach may be used for disinfectant purposes. Soaps, detergents, and bleaches shall not be used at strengths that would attack or harm the rubber surface.

NOTE 1—The cleaning agent shall not degrade the insulating qualities of the gloves and sleeves.

NOTE 2—A commercial tumble-type washing machine may be used, but caution must be observed to eliminate any interior surfaces or edges that will cut, abrade, puncture, or pinch the gloves and sleeves.

NOTE 3—Gloves and sleeves may be suspended to allow drainage and air circulation or dried in a commercial tumble-type automatic dryer. In an automatic dryer, caution must be observed to eliminate any ozone or ultraviolet lamps and interior surfaces that will cut, abrade, puncture, or pinch the gloves and sleeves.

6.4 Prior to the electrical test, gloves and sleeves should be given a preliminary inspection for punctures, tears, cuts, bruises, ozone cutting or checking, or any other obvious conditions that would adversely affect performance. (See Guide **F1236**). If any of these conditions are found, the glove or sleeves shall be rejected, or repaired in accordance with Section 10. Minor surface corona cutting or ozone checking in the gauntlet area, (See **Fig. 1**), above the water line, need not be cause for rejection.

6.5 The gloves and sleeves shall be tested in accordance with Section 7.

6.6 The gloves and sleeves shall not be air-dried with an air temperature in excess of 65 °C (150 °F).

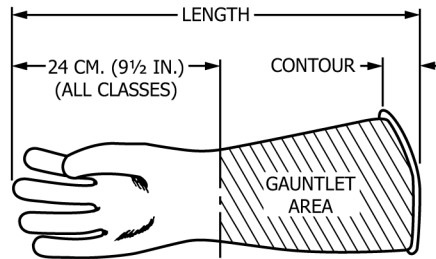

FIG. 1 Rubber Glove—Gauntlet Area (All Classes)

6.7 The gloves and sleeves shall be given a detailed inspection over their entire surface for physical defects and ozone damage. (See Guide F1236). They may be turned inside out for inside inspection, but only for the duration of the inspection. They may be inflated with air to enhance the identification of small defects, but caution shall be exercised to avoid over-inflation (see Note 10). This detailed inspection may be performed prior to the electrical tests, where it can be demonstrated that the electrical testing process does not cause ozone damage.

6.8 The inside surface of gloves may be dusted with a powder. Gloves and sleeves should be sorted by pairs and packed in accordance with Section 8 for field care, inspection, and storage.

7. Electrical Tests

7.1 Electrically retest gloves or sleeves issued for service. Base the interval between date of issue and retests on work practices and test experience. It shall not exceed 6 months for gloves and twelve months for sleeves. Gloves or sleeves that have been electrically tested but not issued for service shall not be placed into service unless they have been electrically tested within the previous twelve months.

7.1.1 Each glove or sleeve shall withstand the 50-Hz or 60-Hz ac retest voltage (rms value) or the dc retest voltage (average value) specified in Table 1. The test voltage shall be applied continuously for not less than 1 min and not more than 3 min.

7.1.2 The insulating gloves tested by the ac method shall also meet the requirements of Table 2.

7.2 **Warning**—The test apparatus should be designed to afford the operator full protection in the performance of his duties. Reliable means of de-energizing and grounding the high-voltage circuit should be provided. It is particularly important to incorporate positive means of grounding the high-voltage section of dc test apparatus due to the likely presence of high-voltage capacitance charges at the conclusion of the test. See ANSI C39.5.

7.2.1 The equipment shall be inspected at least annually to ensure that the general condition of the equipment is acceptable and to verify the characteristics and accuracy of the test voltages.

7.2.2 To eliminate damaging ozone and possible flashover along the glove cuff or sleeve openings, there should be a sufficient flow of air into and around the glove or sleeve and an exhaust system to adequately remove ozone from the test machine. Consistent ozone cutting and checking during the test procedure should be cause to ascertain the adequacy of the exhaust system.

7.3 Industries, such as telecommunications, that utilize insulating gloves as precautionary protection against unintentional contact with energized conductors, may increase the maximum interval between issue and retest to nine months.

7.4 Both ac and dc voltage retest methods are included and either method may be selected for electrical testing.

7.5 Glove Tests:

7.5.1 Perform all electrical tests on clean gloves and at normal room temperatures. Fill the gloves, right side out, with conductive, clean water and immerse to a depth in compliance with Table 3 for the retest voltage to be used. The water level during the test shall be the same inside and outside the gloves. Connect the water inside the glove, which forms one test electrode, and

TABLE 2 AC Proof-Test Current, max, mA

Class Designation of Glove	Retest Voltage, max	Glove, 280 mm (11 in.)		Glove, 360 mm (14 in.)		Glove, 410 mm (16 in.)		Glove, 460 mm (18 in.)	
		50Hz	60Hz	50Hz	60Hz	50Hz	60Hz	50Hz	60Hz
00	2 500	6.7	8	10	12	<sup>A</sup>	<sup>A</sup>	<sup>A</sup>	<sup>A</sup>
0	5 000	6.7	8	10	12	11.7	14	13.3	16
1	10 000	—	—	11.7	14	13.3	16	15	18
2	20 000	—	—	13.3	16	15	18	16.7	20
3	30 000	—	—	15	18	16.7	20	18.3	22
4	40 000	—	—	—	—	18.3	22	20	24

<sup>A</sup> Not applicable.

**TABLE 3 Flashover Clearances Between Electrodes<sup>A</sup>**

Class Designation, Glove or Sleeve	AC Retest		DC Retest	
	in.	mm	in.	mm
00	3	76	3	76
0	3	76	3	76
1	3	76	4	102
2	5	127	6	152
3	7	178	8	203
4	10	254	12	305

<sup>A</sup> Flashover clearances are stated in terms of the shortest electrical air path between electrodes around the edge of the item being tested. In those cases where atmospheric conditions make the specified clearances impractical, the distance may be increased by the maximum of 51 mm (2 in.).

the water in the tank outside the glove, which forms the other electrode, to the opposite terminals of the high-voltage source. The water should be free of air bubbles and air pockets inside or outside the glove and the exposed portion of the glove above the water line shall be dry.

7.5.2 Insulating gloves being retested by the ac method shall meet the requirements of Table 2. If the proof test current is in excess of these limits, the glove shall be rejected.

NOTE 4—For further details on recommended equipment and procedures, refer to Specification D120.

7.6 *Sleeve Tests*— Perform all electrical tests on clean sleeves right side out and at normal room temperature. Seven methods of mounting sleeves are described in the following sections, with test limitations on some of the methods. Both ac and dc proof-test procedures are included in this section. In each of the six test methods, the inner and outer electrodes shall be connected to the opposite terminals of the high-voltage source. Electrode to electrode clearances shall be as specified in Table 3.

7.6.1 *Electrodes:*

7.6.1.1 *Water Electrodes, Inverted Mounting*—In this method, invert the small end of the sleeve and pull through to the large end to form an annular trough as shown in cross section in Fig. 2. (see Note 5). Immerse the sleeve in water and fill the trough with water until the levels both inside and outside the trough are the same. Particular care should be taken to avoid any sharp folds in the sleeves as they may cause premature dielectric breakdown at these points.

NOTE 5—Use of this method may result in excessive breakdown failures when tested above 10 000 V ac or 50 000 V dc if the test apparatus does not conform with 7.2.2.

7.6.1.2 *Water Electrodes, Sling Mounting*—In this method, place a non-insulating pipe or rod at least 51 mm (2 in.) in diameter at about the midpoint between the cuff and underarm edge. The pipe or rod should be of sufficient weight to hold the sleeve down to prevent creasing and its length should be no less than the width of the sleeve. Immerse the sleeve in water with the rod in place and fill with water until the water levels are the same both inside and outside the sleeve, and the cuff and underarm edges are equidistant above the water line as shown in the cross section in Fig. 3 (see Note 5). Particular care should be taken to avoid any sharp folds in the sleeves as they may cause premature dielectric breakdown at these points.

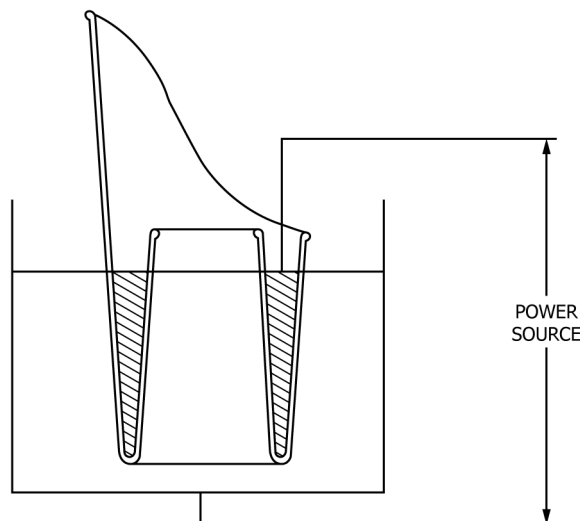

**FIG. 2 Water Electrodes, Inverted Mounting**

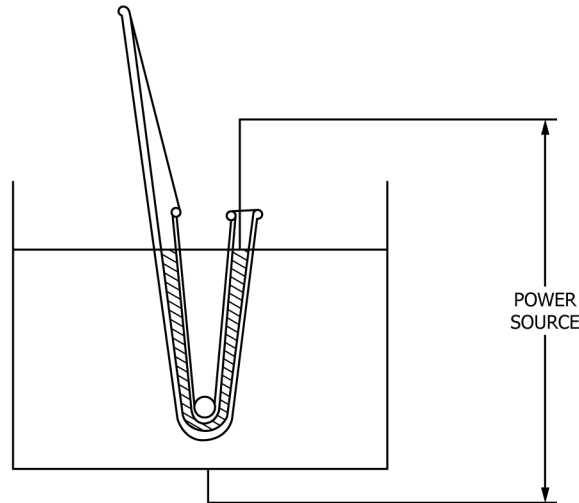

FIG. 3 Water Electrodes, Sling Mounting

7.6.1.3 *Water Electrodes, Hammock Mounting*—The sleeve shall be hung in the test machine so that the top of the shoulder area, the top of the underarm, and the cuff edge are all in a horizontal plane, parallel to the surface of the water in the test tank (see Fig. 4). The test equipment holding or supporting the sleeve under test should be of such design that there is minimal stress created in the sleeve material. Place a rod or pipe across the top surface of the sleeve at approximately the midpoint between the cuff and underarm edge. The pipe or rod shall be noninsulating, at least 51 mm (2 in.) in diameter, and of sufficient weight to hold the sleeve down to prevent creasing. The length of the pipe or rod shall be no less than the width of the sleeve. Fill the sleeve with water and immerse the sleeve to the test position, allowing for proper flashover clearance for the test voltage used. In so far as practical, the water levels should be the same both on the inside and outside of the sleeve, and the top of the shoulder area, the top of the underarm, and the cuff edge are equidistant above the water line (see Fig. 4). Particular care shall be taken to avoid any sharp folds or areas of stress in the sleeve, as they may cause premature dielectric breakdown or ozone cutting, or both, at these points (see Note 5).

7.6.1.4 *Water Electrodes Straight Mounting*—In these methods, a high-dielectric medium is used to separate and electrically isolate the water electrodes inside and outside the vertically mounted sleeve.

(1) *Straight Mounting, Liquid Cuff Seal* (see Fig. 5)— In this method, a high dielectric medium is used to separate and isolate the water electrodes inside and outside the vertically mounted sleeve. Place a layer of high dielectric strength liquid, having a specific gravity greater than 1.0 and insoluble in water, in the test tank to a depth of approximately 51 mm (2 in.) greater than the depth listed in Table 3. Then fill the tank with water to the desired level. Immerse the sleeve, with the cuff end first, into the water until the cuff end is below the interface between the two liquids, to a depth required to provide the flashover clearance shown in Table 3. The dielectric liquid separates and electrically insulates the inside water electrode from the outside water electrode. This mounting may be used for all voltages, both ac and dc.

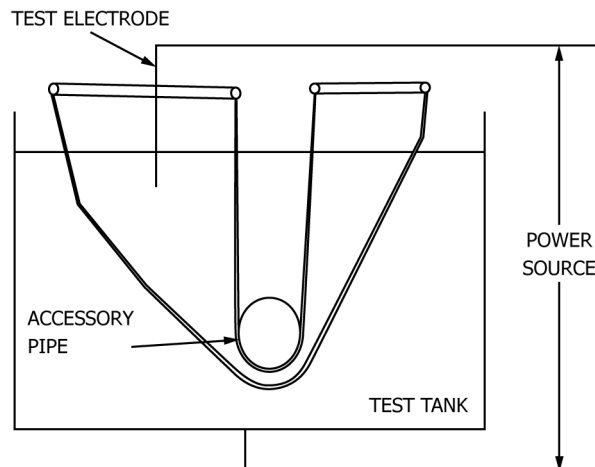

FIG. 4 Water Electrodes, Hammock Mounting

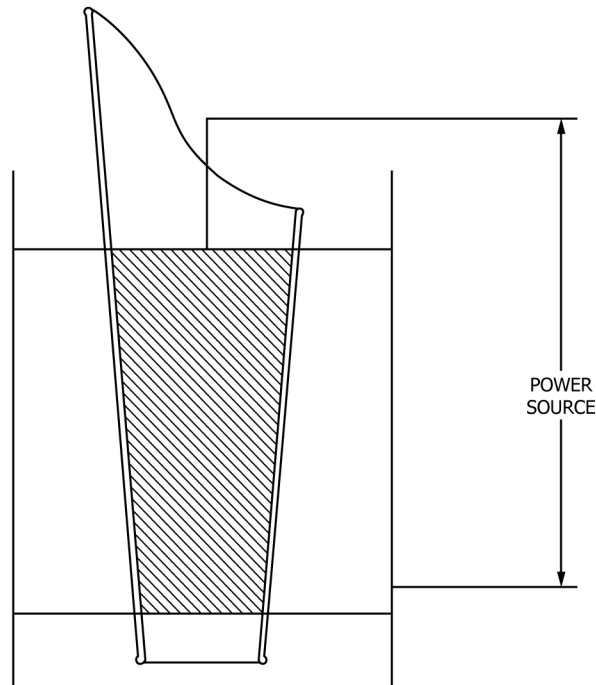

FIG. 5 Water Electrodes, Straight Mounting

NOTE 6—Some dielectric liquids are toxic in nature and therefore proper precautionary measures shall be followed. One satisfactory dielectric liquid is trichlorotrifluoroethane (Dielectric Grade). The rubber sleeve should be exposed to the trichlorotrifluoroethane for only the time needed to complete the test, as extended exposure time will cause temporary distortion of the rubber. Repeated testing may result in loss of dielectric strength due to water dielectric mixing, so separation time or other means may be needed. Care should be taken to prevent the sleeves from folding back out of the dielectric liquid. Hanger systems may be obtained from most test equipment manufacturers to facilitate the hammock mounting method.

(2) *Straight Mounting Mechanical Cuff Seal*—In this method, a mechanical seal is placed on the cuff of the sleeve to be tested. This device shall provide a tight, leakproof seal at the cuff and a high dielectric medium to separate and electrically isolate the inside water electrode from the outside water electrode. The sleeve to be tested is then filled with water to meet the clearance requirements of Table 3. The test arrangement shall provide that the sleeve stay essentially straight. This mounting may be used for all voltages, both ac and dc.

7.6.1.5 *Wet Sponge Electrodes*—A method utilizing sponge electrodes and masking may be used to retest sleeves as in Fig. 6 and Fig. 7. Use a grounded plate as the table. Place a 3.2-mm (1/8-in.) thick ozone-resistant sheet of insulating rubber with a 76-mm (3.0-in.) diameter hole on the table and place 1/8-in. thick wet sponge or wet felt in the hole as the ground contact. Place a second 3.2-mm (1/8-in.) thick ozone-resistant sheet of insulating rubber, with the shape of the sleeve cut out of its surface, on top of the first sheet. Place a 51-mm (2.0-in.) thick wet sponge form, cut to fit inside the sleeve. This inside sponge electrode should be 63 mm (2.5 in.) shorter on each end than the sleeve being tested. Place a wet felt or sponge cloth outer electrode, designed to cover the outside of the sleeve, on the cut out blanket making contact with the ground. Then place the sleeve encasing the sponge in position on the wet felt or sponge which is wrapped around the sleeve. Place an ozone-resistant mask of insulating rubber, 127 mm (5.0 in.) wide and 3.2 mm (1/8 in.) thick, in the undercut of the arms, 51 mm (2.0 in.), to extend the flashover distance in this area. Extend an energizing lead from the voltage source to the inside electrode in the sleeve. Cutouts and electrodes can be made in multiples to test more than one sleeve at a time (See 7.2.2).

NOTE 7—Use of this method with present technology may result in excessive breakdown failures when testing Type I sleeves at voltages above 20 kVAC.

7.6.1.6 *Dry Electrodes, Straight Mounting*—In this method, the electrodes consist of two electrically conductive plates or shapes, constructed to conform closely to the inside and outside of the sleeve. Round any edges on these shapes so as to eliminate sharp nicks and protuberances. Draw the sleeve snugly and without stretching over the inner electrode and place the outer electrode around it and adjust to a snug fit as shown in the cross section in Fig. 8. For versatility in testing sleeves of different sizes, the electrodes can be made longer than those indicated, in which case masking the edges with a nonconductive material will permit testing of larger areas of the sleeve. This method should not be used for ac testing of Type I sleeves because of potential ozone generation.

7.7 AC Test:

7.7.1 Voltage Supply and Regulation: