International Standard



4612

INTERNATIONAL ORGANIZATION FOR STANDARDIZATION • МЕЖДУНАРОДНАЯ ОРГАНИЗАЦИЯ ПО СТАНДАРТИЗАЦИИ • ORGANISATION INTERNATIONALE DE NORMALISATION

Plastics — PVC paste resins — Preparation of a paste

Plastiques — Résines PVC pour pâtes — Préparation d'une pâte

First edition — 1979-08-15

iTeh STANDARD PREVIEW
(standards.iteh.ai)

[ISO 4612:1979](#)

<https://standards.iteh.ai/catalog/standards/sist/9660855c-631a-4e27-bb96-0e000d35b501/iso-4612-1979>

Foreword

ISO (the International Organization for Standardization) is a worldwide federation of national standards institutes (ISO member bodies). The work of developing International Standards is carried out through ISO technical committees. Every member body interested in a subject for which a technical committee has been set up has the right to be represented on that committee. International organizations, governmental and non-governmental, in liaison with ISO, also take part in the work.

Draft International Standards adopted by the technical committees are circulated to the member bodies for approval before their acceptance as International Standards by the ISO Council.

International Standard ISO 4612 was developed by Technical Committee ISO/TC 61, *Plastics*, and was circulated to the member bodies in January 1978.

iTeh STANDARD PREVIEW
(standards.iteh.ai)

It has been approved by the member bodies of the following countries :

Austria	India	South Africa, Rep. of
Belgium	Iran	Spain
Brazil	Israel	Sweden
Bulgaria	Italy	Switzerland
Canada	Japan	Turkey
Czechoslovakia	Kenya	United Kingdom
Egypt, Arab Rep. of	Korea, Rep. of	USA
Finland	Mexico	USSR
France	Netherlands	Yugoslavia
Germany, F. R.	Poland	
Hungary	Romania	

No member body expressed disapproval of the document.

Plastics — PVC paste resins — Preparation of a paste

iTeh STANDARD PREVIEW (standards.iteh.ai)

1 Scope and field of application

This International Standard specifies a method for the laboratory preparation of a paste from PVC paste resins under controlled conditions.

This paste can be used for the control (in particular, of the rheological properties) and comparison of resins.

NOTES

- 1 For certain studies and in particular those concerning application problems, other methods using different apparatus and formulae can be used (for example with stabilizers).
- 2 The method shall not be used if the relative humidity is equal to or less than 20 % as anomalous results can be obtained in such cases.

2 Principle

A standard paste is prepared in a planetary type mixer at a controlled temperature of 23 ± 2 °C by mixing defined quantities of resin and plasticizer, under defined conditions of beater rotational frequency, temperature and time of mixing.

The plasticizer used is di-2-ethylhexyl phthalate (DOP).

3 Reagent

Di-2-ethylhexyl phthalate (DOP).

The quality of new supplies of DOP shall be verified by measuring the viscosity of a paste prepared from it and a previously assessed resin.

4 Apparatus

Usual laboratory equipment, and in particular :

- 4.1 **Balance**, accurate to the nearest 1 g.
- 4.2 **Vessels**, of capacity about 1 litre, for weighing the plasticizer.
- 4.3 **Stopwatch** or **clock** which indicates seconds.
- 4.4 **Beakers**, tall-form, of different capacities, suitable for the quantity of pastes intended for the various individual tests.
- 4.5 **Vacuum pump**, of sufficient capacity to permit the de-aeration of the paste (see note to 5.2).

4.6 Sieve, of aperture size 1 mm.

4.7 Planetary type mixer¹⁾, of the shape illustrated in figure 1, and of the dimensions shown in figure 2, having a motor sufficiently powerful to obtain the specified rotational frequencies²⁾, particularly 20 to 60 and $120 \pm 5 \text{ min}^{-1}$, and to maintain them throughout the mixing procedure, and having a stainless steel bowl and a device (for example a jacket for the circulation of water) to maintain the ingredients and paste at a temperature of $23 \pm 2 \text{ }^\circ\text{C}$ (obligatory requirement).

The circulating fluid shall not produce a significant pressure in the jacket.

If necessary, the mixer may be provided with a rotating wiper to scrape the inside of the bowl. The blade which rotates at the same time as the beater, may be made of polytetrafluoroethylene or other flexible material resistant to DOP (but not of rubber).

5 Procedure

5.1 Formulae for the preparation of the paste

Two reference formulae are given (parts by mass):

$$\left\{ \begin{array}{l} 100 \text{ resin} \\ 50 \text{ DOP} \end{array} \right. \quad \text{and} \quad \left\{ \begin{array}{l} 100 \text{ resin} \\ 70 \text{ DOP} \end{array} \right.$$

designated "100 and 50" and "100 and 70".

NOTE — In certain cases it may be necessary to use other formulae; they should be chosen at intervals of ± 10 parts of plasticizer per hundred of resin (p.h.r.) as for the reference formulae, for example "100 and 40", "100 and 60", "100 and 80".

According to the formula for the relevant paste, calculate the amount of polymer and of DOP in such a way that the total amount is between 650 and 750 g.

Examples :

- for a formula of 50 p.h.r. of DOP, 470 g of resin and 230 g of DOP;
- for a formula of 70 p.h.r. of DOP, 410 g of resin and 290 g of DOP.

5.2 Preparation of the paste

Weigh the calculated amount of resin and transfer it to the bowl of the mixer (4.7).

Weigh the calculated amount of DOP in a 1 litre vessel (4.2).

Place the bowl on the mixer.

Allow the apparatus and products to reach temperature equilibrium at $23 \pm 2 \text{ }^\circ\text{C}$.

Lower the head of the mixer after having fixed the beater in such a way that it is as close as possible to the wall of the bowl.

Add all the DOP together, taking care that it is distributed evenly over the resin.

At the same time, start the stopwatch or clock (4.3) and start the beater at a low rotational frequency of 20 to 60 min^{-1} in air in order to avoid spattering; mix the ingredients until a paste is formed.

At this moment note the elapsed time and stop the beater.

Wipe down both the bowl and the beater with a spatula.

Restart the beater at a rotational frequency of $120 \pm 5 \text{ min}^{-1}$, or at a lower frequency if necessary and if agreed upon (this shall be stated in the report), and continue to mix until the total mixing time, taking into account the first slow mixing time, is 20 min.

Check that the temperature of the paste is $23 \pm 2 \text{ }^\circ\text{C}$. If the temperature is outside these limits, prepare another paste.

Pour the paste into a beaker (4.4) for subsequent tests. Check that the paste is free of lumps by pouring a sample through the sieve (4.6). If there are lumps, prepare another paste.

De-aerate the paste in a desiccator, under a partial vacuum, for example of $7 \times 10^{-2} \text{ Pa}$, at $23 \pm 2 \text{ }^\circ\text{C}$, and maintain it for 5 min after observing the foam collapse.

NOTE — The de-aeration may be effected directly in the mixing bowl used to prepare the paste if the mixer is suitably equipped to apply a partial vacuum.

The paste is then ready for use.

6 Report

The report shall include the following information :

- a) reference to this International Standard;
- b) full identification of the PVC resin used;
- c) formula of the paste, indicated as : "standard paste, 100 and x" where x is the number of parts by mass of DOP per hundred parts of resin (p.h.r.);
- d) rotational frequency of the beater if it is lower than 120 min^{-1} .

1) A suitable mixer is available commercially. Details may be obtained from the Secretariat of ISO/TC 61 (ANSI) or from ISO Central Secretariat.

2) This rotational frequency is that of the beater around the axis of the bowl. (The corresponding rotational frequency of the beater around its own axis is in the ratio 7:3.)

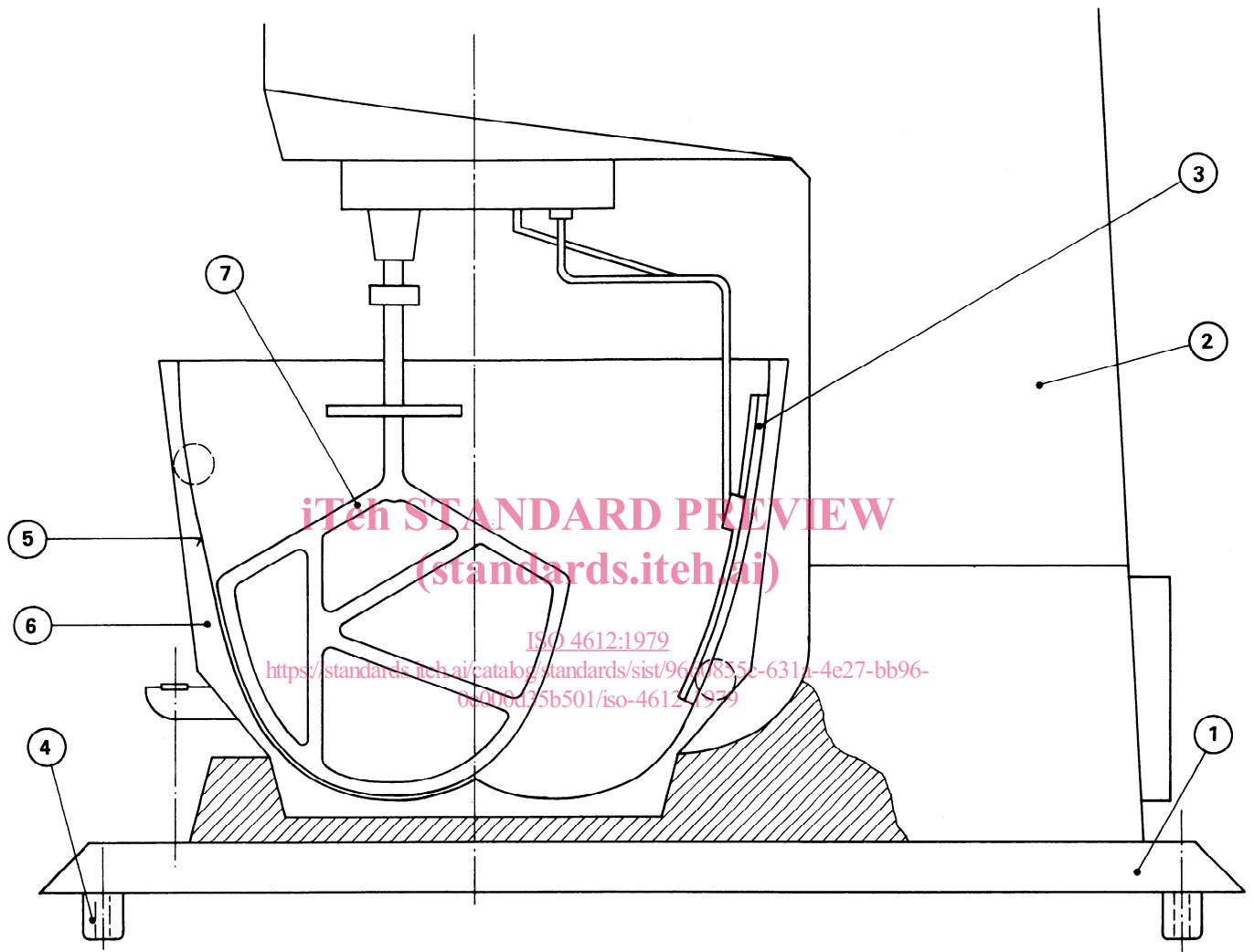

ITeH STANDARD PREVIEW
(standards.iteh.ai)

ISO 4612:1979

<https://standards.iteh.ai/catalog/standards/sist/9667835e-6317-4e27-bb96-630b6d35b501/iso-4612-1979>

- 1 – Base
- 2 – Planetary type mixer
- 3 – Wiper or scraper (rotating to clean inside of bowl)
- 4 – Feet
- 5 – Stainless steel bowl
- 6 – Jacket (for temperature control)
- 7 – Special beater

Figure 1 – General sketch of the modified planetary mixer

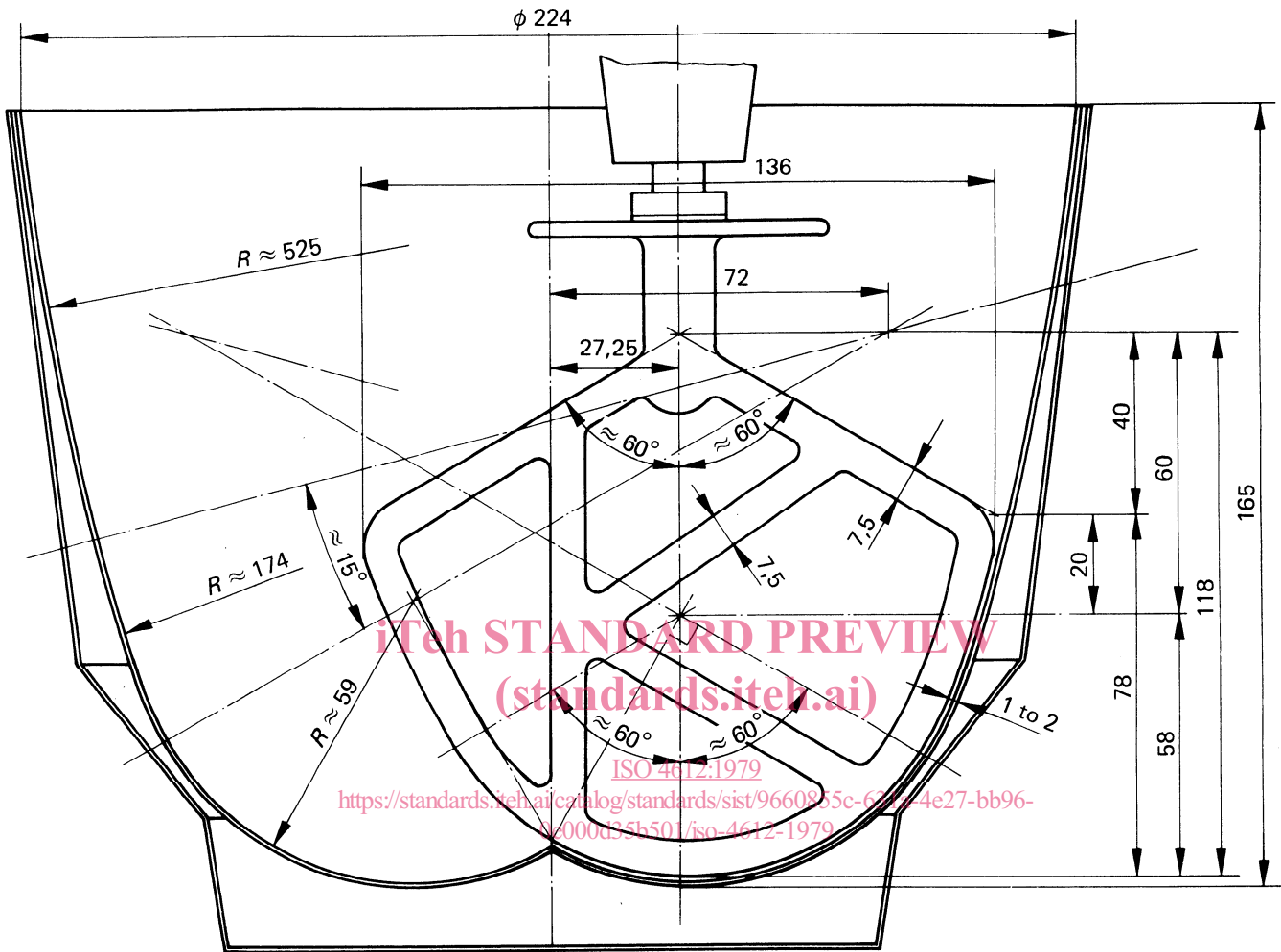

Figure 2 — Principal dimensions of the bowl and the beater

iTeh STANDARD PREVIEW
(standards.iteh.ai)

This page intentionally left blank

[ISO 4612:1979](#)

<https://standards.iteh.ai/catalog/standards/sist/9660855c-631a-4e27-bb96-0e000d35b501/iso-4612-1979>

iTeh STANDARD PREVIEW
(standards.iteh.ai)

This page intentionally left blank

[ISO 4612:1979](#)

<https://standards.iteh.ai/catalog/standards/sist/9660855c-631a-4e27-bb96-0e000d35b501/iso-4612-1979>