



Standard Guide for Conducting Small Boat Stability Test (Deadweight Survey and Air Inclining Experiment) to Determine Lightcraft Weight and Centers of Gravity of a Small Craft¹

This standard is issued under the fixed designation F3052; the number immediately following the designation indicates the year of original adoption or, in the case of revision, the year of last revision. A number in parentheses indicates the year of last reapproval. A superscript epsilon (ϵ) indicates an editorial change since the last revision or reapproval.

^{e1} NOTE—Keywords were added editorially in February 2020.

INTRODUCTION

Small craft operators, builders, buyers, accident investigators, and others may be required to determine the centers of gravity for their craft in order to apply stability criteria or perform other analyses. The conventional in-water stability test can be difficult to perform accurately on small craft, so an in-air inclining experiment may be specified. However, there are no guidelines available to help standardize and explain the process.

This guide provides the marine industry with an understanding of an Air-Incline stability test for small craft. It contains procedures to ensure that valid results are obtained with precision at a minimal cost to owners, shipyards and the government. The guide is not intended to direct a person(s) in the actual calculations of the lightcraft weight and centers of gravity, but to be a guide to the recommended procedures required to gather accurate data for use in the calculation of the lightcraft characteristics.

A complete understanding and documentation of proper procedures to conduct a stability test is paramount to confirm that the results gathered during the test can be examined for accuracy, especially by third parties subsequently reviewing the data. This guide is recommended to be used for all small craft capable of being lifted safely with forward and aft pick points capable of enduring additional inclining weights to be used for the stability test.

1. Scope

1.1 This guide covers the determination of a small boat's lightcraft characteristics. The air incline stability test can be considered two separate tasks; a deadweight survey and an air-inclining experiment. The stability test is recommended, but not required, for all small craft upon their construction completion or after major conversions, or both, where stability information is required. It is typically conducted indoors and an enclosed facility to protect the vessels from unprotected environmental conditions.

1.2 *This standard does not purport to address all of the safety concerns, if any, associated with its use. It is the responsibility of the user of this standard to establish appropriate safety, health, and environmental practices and determine the applicability of regulatory limitations prior to use.*

¹ This guide is under the jurisdiction of ASTM Committee F25 on Ships and Marine Technology and is the direct responsibility of Subcommittee F25.01 on Structures.

Current edition approved Feb. 1, 2020. Published February 2020. Originally approved in 2014. Last previous edition approved in 2014 as F3052 – 14. DOI: 10.1520/F3052-14R20E01.

1.3 *This international standard was developed in accordance with internationally recognized principles on standardization established in the Decision on Principles for the Development of International Standards, Guides and Recommendations issued by the World Trade Organization Technical Barriers to Trade (TBT) Committee.*

2. Referenced Documents

2.1 *ASTM Standards:*²

F1321 [Guide for Conducting a Stability Test \(Lightweight Survey and Inclining Experiment\) to Determine the Light Ship Displacement and Centers of Gravity of a Vessel](#)

3. Terminology

3.1 *Definitions:*

3.1.1 *deadweight survey, n*—comprises weighing the vessel at two longitudinal points to determine the total weight and

² For referenced ASTM standards, visit the ASTM website, www.astm.org, or contact ASTM Customer Service at service@astm.org. For *Annual Book of ASTM Standards* volume information, refer to the standard's Document Summary page on the ASTM website.

longitudinal center of gravity of the craft, then auditing all items found on board to be added, deducted or relocated on the craft at the time of the stability test so the observed condition of the small craft can be adjusted to the specified lightcraft condition. All loose items or outfit equipment (that is, anchor, anchor warp, dock lines, fire extinguishers, etc.) found on board should be removed completely from the craft and weighed separately on a calibrated scale.

3.1.2 *inclining experiment, n*—comprises moving a series of known weights in a transverse direction and then measuring the resulting change in the equilibrium heel angle of the craft. This information is used to calculate the vessel’s vertical center of gravity.

3.1.3 *keel (baseline), n*—the datum point used for measuring the vertical location of the pivot points and subsequently defining the vertical location of the weights involved in the test. It is often the lowest point of the craft hull, but may be defined as any convenient point, provided it is consistent within the experiment, consistent with any other documentation such as the drawings or weight estimate, and well documented.

3.1.4 *lightcraft, n*—a small craft, or boat in the lightest condition (“Condition 1”) is a boat complete in all respects without consumables, stores, cargo crew and effects and without any liquids on board except machinery fluids, such as lubricants and hydraulics at operating levels. The lightcraft should be as defined in the craft procurement or other specifications, or in the operating manual, as to outfit permanently aboard, etc.

3.1.5 *stern reference point (SRP), n*—the intersection of the transom and the keel (baseline) of the boat or as otherwise defined in the documentation, but should be clearly defined and documented in the test report, and should be verified by physical measurement at the time of the test relative to the lift

points. The SRP is where all relative locations of outfit and centers of gravity should be referenced in Fig. 3.

3.2 *Symbols:*

3.2.1 *B*—vertical distance from SRP to pick points and roll axis/centerline of knife edges.

3.2.2 *LCG*—longitudinal center of gravity measured from the SRP.

3.2.3 *Tan θ*—tangent angle of deflection.

3.2.4 *VCG*—vertical center of gravity measured from the baseline.

3.2.5 *W*— $W_1 + W_2$, is total weight of the boat.

3.2.6 *W₁*—weight in pounds at the aft pick point.

3.2.7 *W₂*—weight in pounds at the forward pick point.

3.2.8 *X*—longitudinal distance from stern reference point (SRP) to longitudinal center of gravity of the boat.

3.2.9 *X₁*—longitudinal distance from stern reference point (SRP) to aft pick point.

3.2.10 *X₂*—longitudinal distance from stern reference point (SRP) to forward pick point.

4. Significance and Use

4.1 From the lightcraft characteristics, calculations of the stability characteristics of the small craft for all load conditions can determine compliance to applicable stability criteria or provide mass properties information for other analyses or investigations. Accurate results from an air incline stability test may therefore determine future survival of the boat, the crew and compliment. If the small craft is not 100 % complete or there is fuel or other liquids in a tank that is supposed to be clean and dry then the person leading the stability test must determine the acceptability of all variances from the guide based on the ability to correct for these variances analytically.

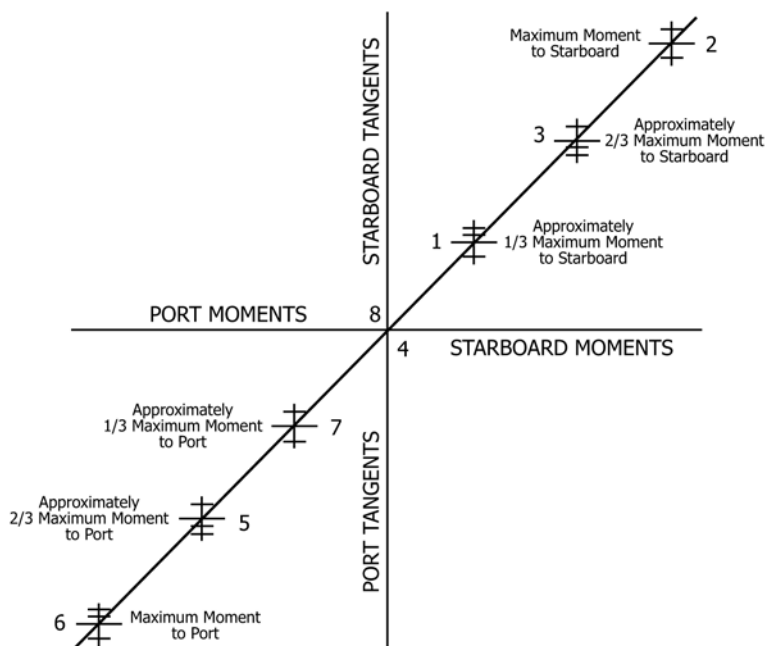

FIG. 1 Typical Incline Plot

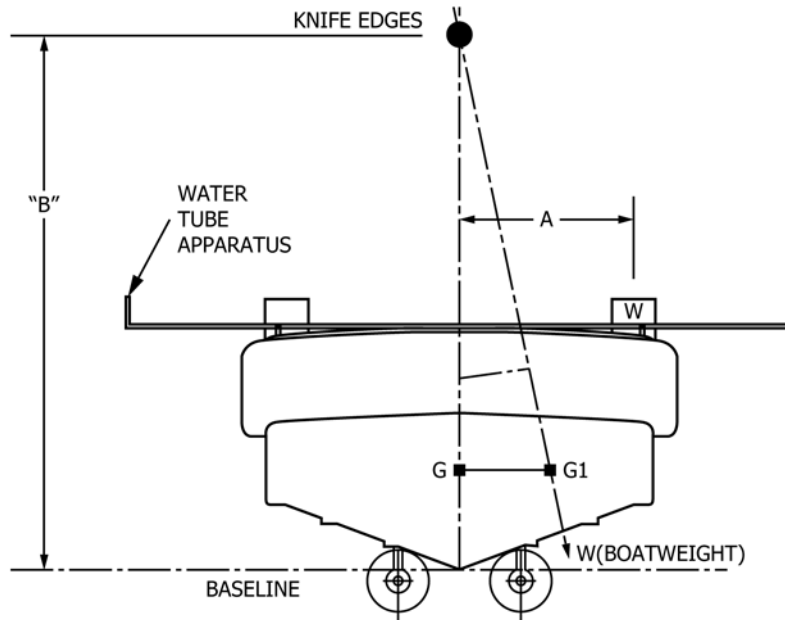

FIG. 2 Measurement of KM, GM, & KG

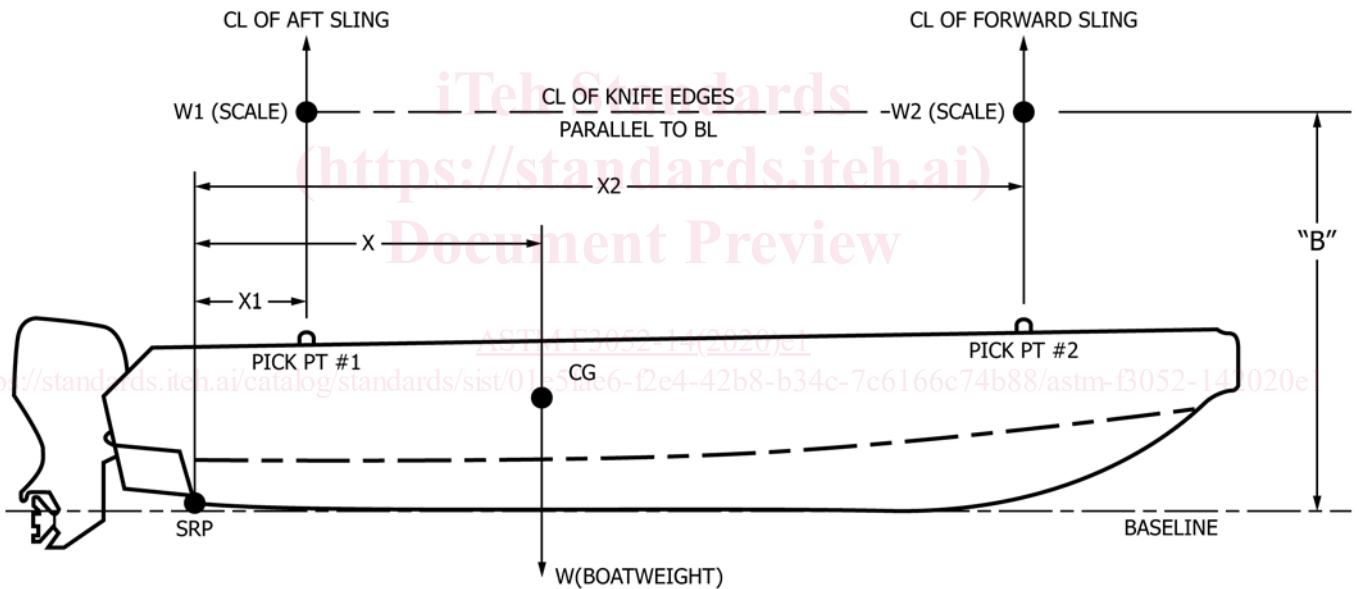

FIG. 3 Relationships of Pick Points and Center of Gravity

A complete understanding of the principles behind the stability test and knowledge of the factors that affect the results is therefore necessary.

4.2 The results of the stability test typically supersede the corresponding values in the weight estimate for any subsequent use in ascertaining compliance to stability or weight control criteria and may be used in weight margin adjudication.

5. Theory

5.1 This test is analogous to the standard in-water inclining test of Guide F1321 and the basic concepts are similar, but the information determined by the readings of the scale(s) and the location of the pivot point are substituted for the hydrostatic properties of the floating vessel in an in-water inclining

experiment. Similar terms are used in some cases based on this analogy, but these terms should not be confused with those derived from hydrostatic data.

5.2 *The Metacenter*—The transverse metacenter “M” is the point around which the boat swings through small angles of inclination (typically 0° to 5°). This is the point at which transverse movement is not constrained relative to the craft hull. For example, as shown in Fig. 5, the lift straps constrain the lower shackle from moving transversely relative to the craft hull, but there is no such constraint on the upper shackle, so the lower shackle pivots on the contact surface between the upper and lower shackles and the metacenter is at their mutual contact point. The height of “M” above “K” is known as “KM”. The location of M is fixed over the range of angles of

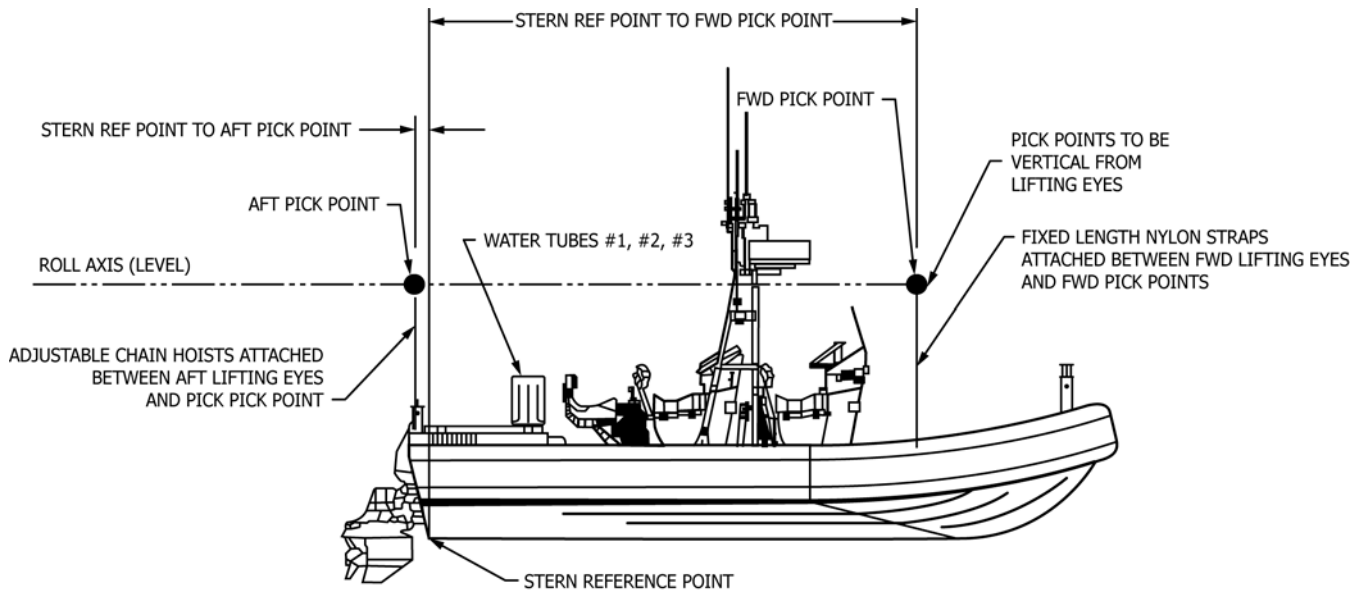

FIG. 4 Typical Lifting Arrangement with Pick Point References and Water Tube Location

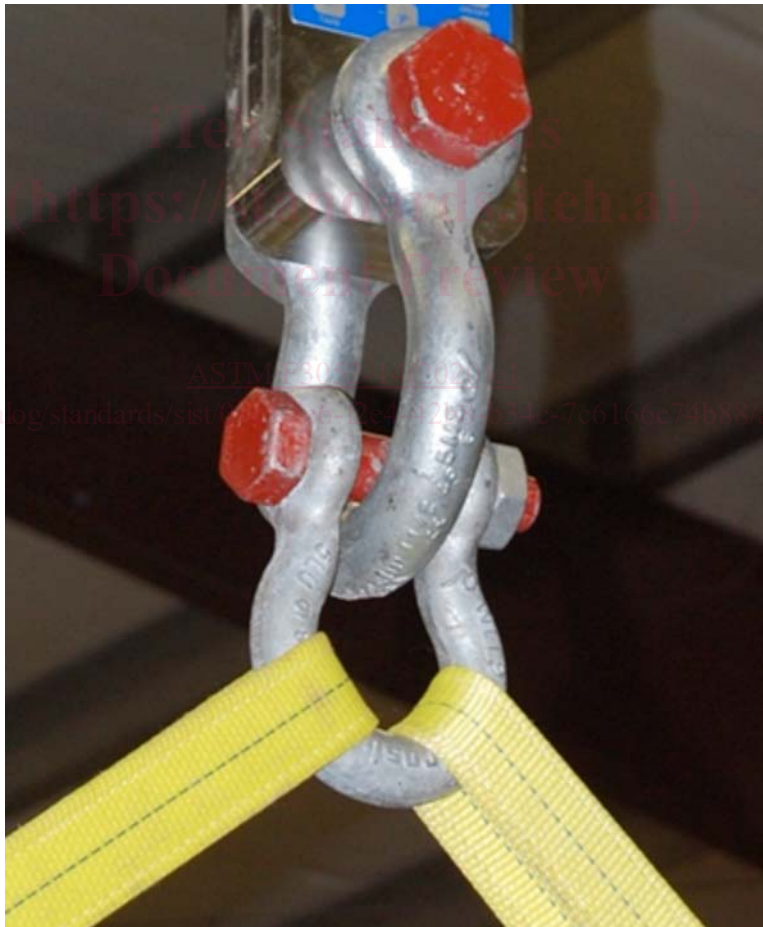

FIG. 5 Improvised “Knife-Edge” Configuration (Forward and Aft) Pick Points

inclination during the stability test. The intersection between the bearing surfaces of the shackles is known as the “*knife-edge*”. It is imperative that this height, “KM”, be exactly parallel between the forward and aft pick points and the

baseline of the boat. Note also that one source of error in this experiment is inaccurate or inconsistent location of the pivot point. It is important the system from the craft hull to the pivot point be effectively rigid in the transverse plane and the pivot

point itself be completely free to rotate through the full range of observed angles of inclination without any binding.

5.3 Metacentric Height—The vertical distance between the center of gravity “G” and “M” is called the metacentric height, “GM”. At small angles of inclination, GM is equal to the initial slope of the righting arm “GZ” curve and is calculated based on the relationship:

$$GZ = GM \sin \theta \quad (1)$$

GM is a measure of stiffness in roll that can be calculated during the air inclining experiment. Moving a weight “w” across the deck a distance “A” will cause a shift in the overall center of gravity “GG₁” of the small craft equal to:

$$GG_1 = \left(\frac{(w)(A)}{W} \right) \quad (2)$$

and parallel to the movement of “w”. The small craft will list over to a new equilibrium heel angle. Because the angle of inclination during the stability test is small, the shift of “G” can be approximated by:

$$GM_1 = \left(\frac{(w)(A)}{W(\tan \theta)} \right) \quad (3)$$

Because the GM and weight remain constant throughout the entire air inclining experiment, the ratio in Eq 3 will remain constant. A series of weight shifts will result in a plot of tangents at the corresponding moments. This ratio is the slope of the best represented straight line drawn through the plotted points as shown in Fig. 1. The line does not necessarily pass through the origin or any other particular point, for no single point is more significant than any other point. Therefore, a linear regression analysis should be used to fit a straight line through the points.

5.4 Calculating the Height of the Center of Gravity Above the Keel—KM remains constant throughout the entire stability test and is represented as “B”, see Fig. 2. The metacentric height, GM, as calculated in Eq 3, is determined from the inclining experiment. The difference between KM and GM is the center of gravity, KG. Therefore, the center of gravity above the keel is:

$$KG = B - GG_1 \cos \theta$$

$$KG = B - \frac{wA}{W} \cos \theta \quad (4)$$

5.5 Calculating the Weight of the Boat—The weight of the boat is obtained by adding the two calibrated scale readings, W₁ + W₂, Fig. 3. The distance “X” of the longitudinal center of gravity from the stern reference point (SRP) is calculated by taking the moments:

$$W_1 X_1 + W_2 X_2 = W(X) \quad (5)$$

$$X = \frac{W_1 X_1 + W_2 X_2}{W} \quad (6)$$

5.6 Measuring the Angle of Inclination—Each incidence where an inclining weight, “w”, is shifted a distance, “x”, the boat will settle to some final equilibrium heel angle, “θ”. To accurately measure this angle, pendulums, a digital inclinometer, a set of water tubes, pendulums or any combi-

nations thereof can be used. At least three independent means of measuring the angle should be used.

5.7 When pendulums are used, the two sides of the triangle defined by the pendulum are measured, “Y”, is the length of the pendulum from the pivot point to the ruled batten and “Z” is the distance the pendulum deflects from the initial reference position along the ruled batten where transverse deflections are measured. Tangent “θ” is then calculated, see Fig. 6:

$$\tan \theta = Z/Y \quad (7)$$

Plotting the readings during the stability test will aid in the discovery of a bad shift in weight or deflection. Since Eq 1 should be constant, the incline plot theoretically should be a straight line. Deviations from a straight line are indicators that there are other moments acting adversely on the craft or the height of “B” is not the same at the fore and after sling pick points. These errors should be identified and corrected and the weight shift repeated until a straight line can be achieved.

5.8 Free Surface—During the stability test, the inclining of the vessel should result solely from the movement of the inclining weights. It should not be inhibited or exaggerated by unknown moments of shifting of liquids or on board components so all such liquids or other weights should be removed or documented so that they can be corrected for during the analysis. Note also that any free surface has the effect of reducing the observed roll stiffness of the system, because it is similar to an additional inclining weight. This means that free surface effects have the effect of raising the observed KG and therefore are subtracted from the observed KG resulting in a lower lightcraft KG.

5.8.1 Tankage During the Air-Inclining—There should not be any liquids on board with the exception of machinery fluids, such as lubricants and hydraulics at operating levels as defined in the specified lightcraft condition. Unless the exact weight and distance of liquid shifted can be precisely calculated, the GM from Eq 1 will be in error. Free surface should be minimized by emptying the tanks completely and making sure all bilges are dry. The shifting of fluids within tanks due to the entrapment of air or pocketing within a complex tank causes considerable errors in the computation of the GM. Note especially that tanks near to empty or full may exhibit heeling moments that vary with the inclining angle as the fluid in the tank touches the top of the tank or as part of the bottom of a tank goes dry. These varying moments severely degrade the accuracy of the test, so tank loads that may produce these effects should be avoided.

6. Preparations for the Stability Tests

6.1 General Condition of the Small Craft—The boat should be as complete as possible at the time of the stability test. The boat will be inspected and any standing water and loose items of “outfit” (anchor, anchor warp, dock lines, fire extinguishers, etc.) found on board should be removed completely or stored securely as specified in any procurement documentation or operator’s manuals if they are defined as part of lightcraft in that documentation. Seacocks and drainage pipes should be dry. The exterior of the hull(s) should be clean and dry. Fig. 4

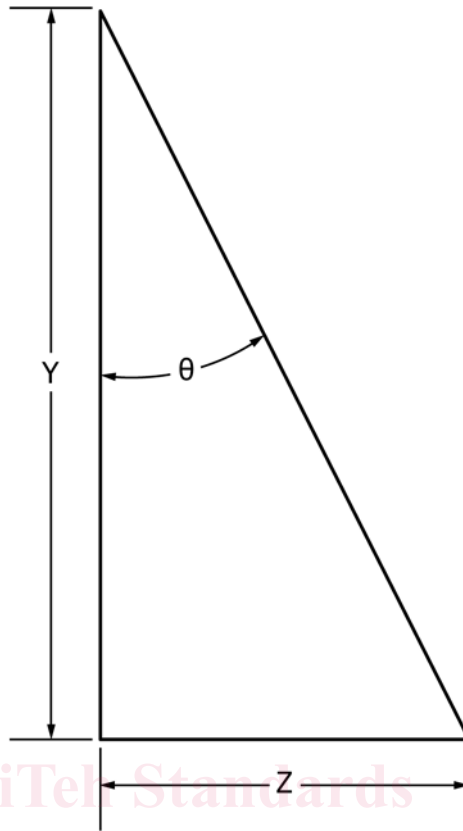

iTech Standards
(<https://standards.iteh.ai>)
Document review

$$\tan \theta = Z/Y$$

$$\tan 4^\circ = 6 \text{ in.}/Y$$

$$Y = 6 \text{ in.}/\tan 4^\circ$$

$$Y = 6 \text{ in.}/0.0699$$

$$Y = 87 \text{ in.}$$

$$\tan 3^\circ = 6 \text{ in.}/Y$$

$$Y = 6 \text{ in.}/\tan 3^\circ$$

$$Y = 6 \text{ in.}/0.0524$$

$$Y = 114 \text{ in.}$$

$$\tan 2^\circ = 6 \text{ in.}/Y$$

$$Y = 6 \text{ in.}/\tan 2^\circ$$

$$Y = 6 \text{ in.}/0.0349$$

$$Y = 172 \text{ in.}$$

FIG. 6 Angle of Inclination versus Pendulum Length

is an example of a typical lifting arrangement diagram used in an air incline stability test.

6.1.1 The small craft should have structurally sufficient lifting points forward and aft or should be lifted by slings or by rigid frames designed for the purpose. The lift means should not shift in any respect during the test. Slings should be marked at the contact point with the hull or secured by tape to the hull such that any slipping can be readily observed.

6.1.2 The boat should be suspended by slings or other hoisting gear forward and aft. Each sling should be vertical and should connect to a “knife-edge” defining the metacenter. The arrangement of shackles, as shown in Fig. 5 is a typical such configuration. The slings should be adjusted so that the craft

baseline is level within one inch over the length of the craft and parallel with the forward and aft metacenters or knife edges, which should also be level within one inch. In Fig. 3, the height of “B” must be equal at the forward and aft pick points within one inch. At each pick point, there should be a calibrated scale with a rated capacity greater than that of the total estimated weight of the boat. It is possible to use one scale and a link of the same length (within 1/8 in.) instead of two scales. In this case, the craft should be lifted twice, once with the scale in the forward position and the link aft and once with the positions reversed, but the requirements above for level positions of the metacenters should be verified in both lifts. The subsequent inclining process may be done with the link and scale in either

position. The scale(s) should have a current calibration certificate, which should be copied and recorded on the test documentation.

6.2 *Tankage*—All tank(s) should be empty and clean. Alternatively, the fuel tank(s) can be pressed full or 100 %.

6.2.1 *Pressed Tanks*—Tanks that are completely full with no voids caused by trim, heel, or inadequate venting. Anything less than 100 % is unacceptable. 98 % condition regarded for full operational purposes is unacceptable. The craft should be rolled side to side to eliminate entrapped air before starting the air incline. Special care should be taken when pressing fuel tanks to prevent accidental over flow or pollution.

6.2.2 *Empty Tanks*—It is generally not sufficient to pump tanks until suction is lost. All attempts should be made to ensure a tank(s) are empty prior to the stability test. This may require physical inspection through a manhole or other means such as a video bore scope.

6.2.3 *Slack Tanks*—Half full tank(s) are undesirable during the stability test and are susceptible to errors in the air inclination plot.

6.3 *Test Weights*—The total weight used should be sufficient to provide a minimum inclination of 1 degree and a maximum of 4 degrees of list.

6.3.1 A means to estimate the amount of weight needed is as follows:

6.3.1.1 Measure the maximum athwartships distance, x , available on deck to shift incline weights.

6.3.1.2 Take the combined weight readings from the fore and aft scales used for the experiment.

6.3.1.3 Estimate a reasonable GM of the boat (as defined by this test, not the hydrostatic GM), typically, this is no less than 1.5 ft. This can be done by using the KG from the construction weight estimate compared to the metacenter as defined by the height B in Fig. 3. In the absence of a weight estimate, KG is generally near the sheerline.

6.3.1.4 Calculate the total incline weight, w , required to heel the boat within the limits of inclination in 6.3.

$$w = \left(\frac{(G M)(\tan \theta)(W)}{(x)} \right) \quad (8)$$

where:

θ = the desired angle of inclination between 1 and 4 degrees.

6.3.2 It is prudent to have additional weights readily accessible to compensate for any inaccuracies.

6.3.3 Test weights should be compact and easily moveable by personnel or crane and in such configuration that the vertical centers can be accurately determined. Mark each weight accordingly with an identification number and weight. One means of accurately determining the effective centers of the weights and making them convenient to handle without requiring anyone to get onto the boat is to suspend the weights from the boat gunwales. The accuracy of the process can be improved by providing a definite point of suspension, such as a hook from a beam placed on the boat or an angle on the side of the hull that the suspension strap passes over. The center of gravity of the weight is then the point of suspension. If

suspended weights are used, verify that they are free to swing transversely throughout the range of inclining angles.

6.3.4 At least three inclined positions should be done from level in each direction (port and starboard). This requires three weights or groups of weights of roughly equal size, on each side, that can be moved separately for each “move” or position, for a total of six weights or weight groups.

6.3.5 Test weights should be certified using a certified scale. Performing the weighing close to the time of the stability test will ensure accuracy.

6.3.6 An additional crane, not one being used for the stability test, or some other means, such as a forklift may be required during the stability test to shift test weights in a safe and efficient manner.

6.3.7 Consider where the test weights will reside on the deck of the boat during weight movements. If deck strength is a concern, check the scantlings below the deck to determine if the existing scantlings can support the additional weight.

6.3.8 Test weight centers of gravity should be at the same vertical and longitudinal location in both the original and shifted positions.

6.4 *Pendulums:*

6.4.1 Pendulums should be arranged to be conveniently situated, in any location on the boat, longitudinally and transversely, and importantly where personnel can accurately read them without disturbing the boat, typically aft of the transom of the boat or forward of the bow. No pendulum or any other means of measuring angle should require a person aboard the boat. No pendulum or any other means of measuring angle should require a person be under the boat, and no person should be under the boat while suspended as any part of this procedure. It also is preferable that no person be required to board the boat once it is suspended.

6.4.2 The pendulum(s) should be long enough to give a measured deflection of at least 4–6 in. to each side, and a precision equivalent to a 1/8 in. deflection of an eight foot pendulum. Generally this requires a pendulum length of about 8–10 ft. A longer pendulum produces more accurate results, however, may take more time to settle down which in this case the accuracy of the results may be questionable. With smaller boats, increasing the weight as prescribed in 6.3 will increase the heel thus utilizing a shorter length pendulum. As shown in Fig. 6, pendulums must be at least 87 in. long to get at least 6 in. of deflection to either side without exceeding the 4 degree maximum heel.

6.4.3 The pendulums are fixed to a point on the craft, as is the batten used to record deflections. The damping trough should be below the batten and may be on the boat or on the floor, but if it is on the floor its weight and its free surface effect need not be deducted from the craft weight condition. Note that the damping trough is not connected to the battens or the pendulum, so it may be moved as required to ensure that the bob doesn't contact the sides of the trough. This also means that the trough need not be of any particular shape as long as it allows the bob to be free from contact with the sides; a regular round bucket is generally acceptable.

6.4.4 A weighted winged pendulum bob (such as two angles connected at their heels) should be immersed in a trough filled

with a liquid to dampen oscillations after each weight movement. Liquid detergent generally works well. The trough should be deep enough to prevent the pendulum bob from touching the bottom.

6.4.5 Battens used to record the readings should be smooth, easy to read and securely fixed in position so that an inadvertent contact will not create a bad reading. They should be marked with a horizontal datum line that defines the lower point of the vertical height of the pendulum. The battens should be aligned close, but not touching the pendulum. The deflection used to calculate the inclining angle comprises the location of the pendulum string where it crosses the datum line of the batten. This is recorded on battens which may comprise a scale for noting the deflections or a markable surface. If necessary, a mirror or other reflective surface one or behind the batten may be used to visually align the pendulum line and its image and thereby correct for any error due to misalignment.

6.5 *Water Tubes:*

6.5.1 Water tubes may be substituted for pendulums; however, at least one pendulum must be used for the test.

6.5.2 At a minimum, three (3) water tubes should be arranged to allow personnel to read and record deflections caused by the weight shift during the stability test on either side of the boat. Like the pendulum, the greater the span between the vertical ends of the water tube apparatus, the higher the deflection readings when shifting the weight. Water tubes should be arranged to give equivalent measurement precision as a pendulum. Water tubes should be located forward, midship, and aft.

6.5.3 The flexible water tubes should be long enough to lay freely athwartships on the boat and extend vertically on the ends of an apparatus, see Fig. 7. The tubes should not come in contact with the ground.

6.5.4 Make sure the water tube is free of any air bubbles. Trapped air bubbles will cause an error in the deflection

readings. Generally, when using three water tubes in parallel with one another, different colored dye is added to each water tube to allow personnel recording the deflections to do so without discrepancy. This also ensures that the port and starboard legs of the tube are correctly matched. Note that a stopcock on each end of each tube allows them to be moved or otherwise inclined without loss of the fluid, but verify that the stopcocks are fully open during each measurement.

6.5.5 Rulers or battens should be fixed to the vertical ends of the water tube apparatus to easily read the deflection in the water tube, as shown in Fig. 8. Measurements of the deflections recorded must be readable to 1/16 in. and a minimum of 6 in. of deflection must be attained above and below the zero point on each side of the vessel.

6.5.6 The water tube apparatus is usually located in an unobstructed section of the boat deck where it can pass freely from side to side. Note that the tube connecting the water levels may run freely vertically and fore and aft, etc. as convenient provided that no point on the tube is higher than the measurement area and that no air pockets are formed.

6.6 *Digital Inclinerometers:*

6.6.1 A calibrated digital inclinometer may be used for quick reference validation and not to substitute the pendulums or water tubes. They should be located with the active axis athwartships and in an unobstructed area easily viewed by personnel to record. They should have a precision equivalent to at least ±0.01 degrees and an accuracy of ±0.05 degrees. If the reading does not stabilize at a single number, an average of at least five maximum-minimum swings (therefore, ten readings) should be recorded for each weight movement.

6.6.2 Manufacturer's data or certification for the inclinometer must also be submitted.

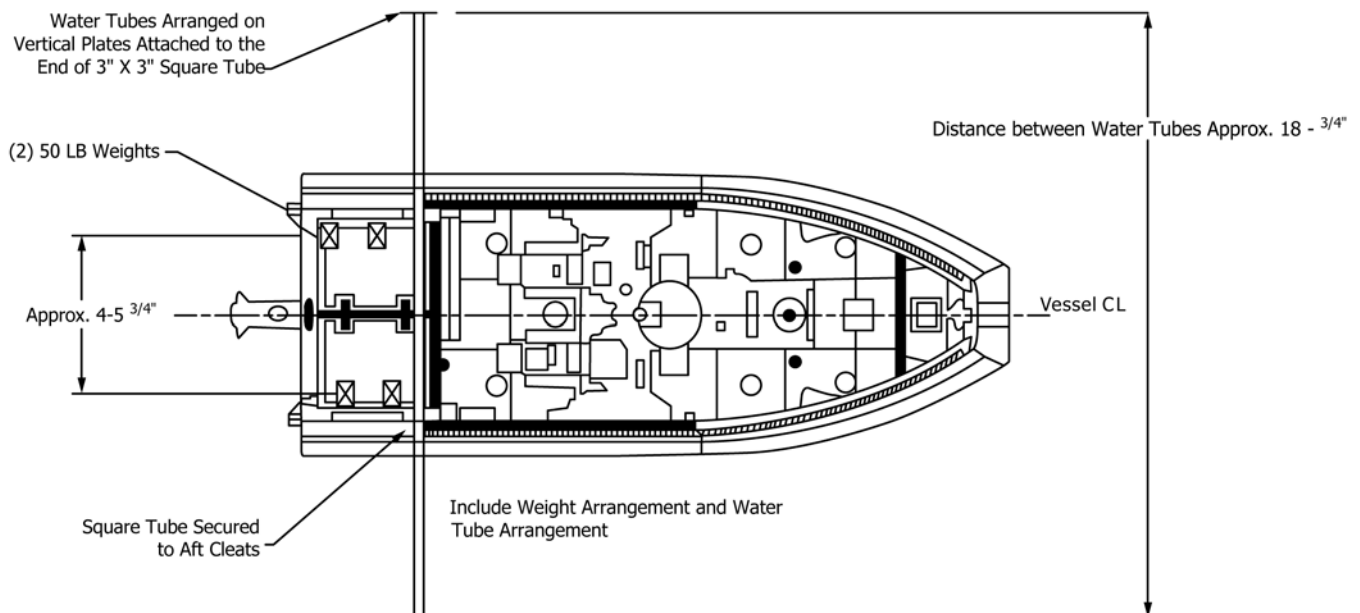

FIG. 7 Typical Water Tube Arrangements

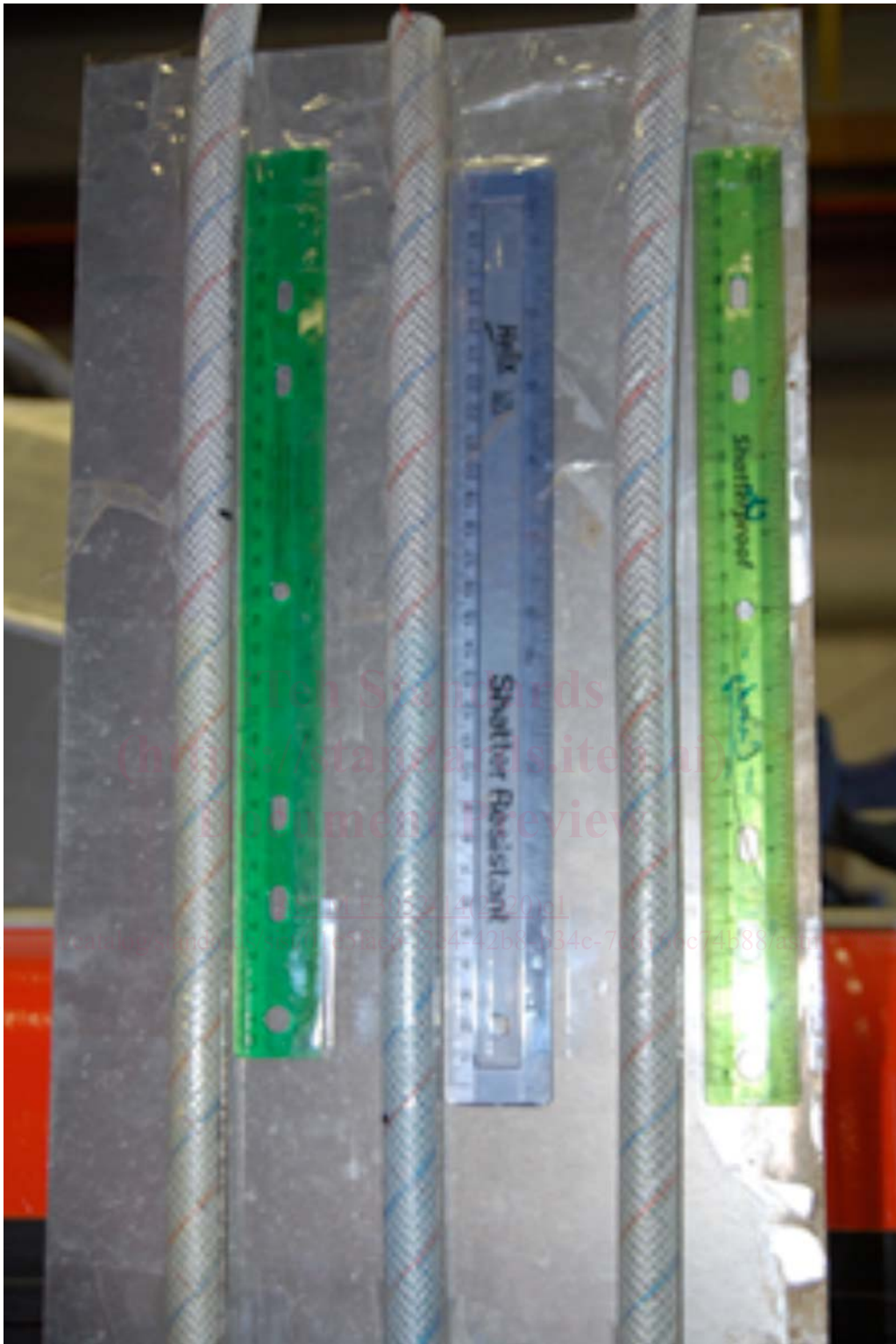

FIG. 8 Typical Water Tube Deflection Recording Station

6.7 *Laser Level:*

6.7.1 A laser level can be used during a stability test to check for even trim of the boat.

6.7.2 A laser transit can be used to assure the knife-edge pick points and the boat baseline are level and parallel.

6.7.3 A laser level or optical transit can be used for determining the inclination of the boat. If used, this should be only one of at least three independent means of determining the inclination of the boat and should be shown by calculation to give equivalent precision to 0.1 % slope.

6.8 *List and Trim*—The most crucial procedure for the stability test is to ensure that the boat should be as close as possible to even trim and list hanging from fore and aft cranes. A water tube or laser transit can be used to ensure the boat is level and that the fore and aft pick/lift points are the exact distance from the baseline. With inclining weights in the initial position, up to ½ ° of list is acceptable. If the list exceeds the acceptable limit, use leveling weights to put the vessel at an acceptable condition.

6.9 *Communication Arrangements:*

6.9.1 One person at a central location within the stability test facility should have ultimate control over all personnel involved with the test.

6.9.2 If necessary, efficient two-way communications between central control and weight handlers and central control and data collectors.

6.9.3 Ultimately, the stability test should be administered indoors in an enclosed facility with no less than two cranes to avoid any environmental effects (that is, wind, rain, etc.) during the test; however, if an enclosed facility cannot be provided, a test can be satisfactorily administered outdoors in calm conditions (that is, no wind, no rain, etc.). The test leader should determine the results satisfactory by monitoring the plot and noting any major deflections or errors.

6.10 *General:*

6.10.1 If the person administering the test desires to substitute inclinometers or other measuring devices for pendulums or water tubes, they should complete prior testing of the measuring devices to verify their accuracy. It is recommended that such devices be used in conjunction with at least one pendulum or water tube as mentioned in 6.4 of this guide instead of using only other devices and no pendulum or water tubes.

6.11 *Additional Requirements:*

6.11.1 **Annex A1** contains additional requirements that must be met, if U.S. Coast Guard approval of the stability test is needed.

6.11.2 **Annex A2** contains additional requirements that must be met for stability tests on U.S. Navy vessels.

7. Plans and Required Equipment

7.1 *Plans*—The person in charge of the air inclining should have available a copy of the following at the time of the stability test:

- 7.1.1 General arrangement plan;
- 7.1.2 Outboard/Inboard profile;
- 7.1.3 Midship section;
- 7.1.4 Capacity plan (if available) showing capacities and centers of gravity of tanks and so forth.

7.2 *Equipment*—Besides the physical equipment necessary, the following are necessary to the person in charge of the air incline procedure:

- 7.2.1 Sufficient number of engineering scales or equivalent devices for measuring pendulum and water tube deflections;
- 7.2.2 Sufficient number of pencils to mark deflections or record deflections, or both;
- 7.2.3 Chalk for marking various positions of the incline weights;

7.2.4 A sufficiently long measuring tape (steel, 100 ft) for measuring the movement of the inclining weights;

7.2.5 Duct tape;

7.2.6 Ladders to access the hull when lifted;

7.2.7 Digital camera;

7.2.7.1 It is important to record where and the timing of when a photograph was taken to avoid any discrepancies later when generating the final report.

7.2.8 Flashlight;

7.2.9 Calculator;

7.2.10 Permanent marker;

7.2.11 Graph paper to plot inclining moments, sufficient number of pads of paper to record information or a single computer station configured to track the air inclining results, or both;

7.2.12 At least two (2) calibrated scales rated to accept the total estimated weight of the craft;

7.2.13 At least two (2) adjustable chain hoists or other means of adjusting the length of the lift gear between the boat and the knife edge if the craft has dedicated lift points that are appropriate for this test;

7.2.14 Assortment of shackles to provide extra length of straps if needed;

7.2.15 If the craft does not have appropriate lift points, two (2) nylon slings rated at the capacity of one of the scales and slings of adequate length (that is, approximately 30 ft) fitted with means to adjust the sling length so that the required level and parallel relationships of the craft and the lift points may be achieved. Note that the adjustment means must be in the sling such that the spread of the sling legs is maintained as shown in Fig. 5. This ensures that the knife edge is the true pivot point. The adjustable means should not be between the point where the two legs come together and the knife edge.

7.2.16 Other means of connecting the craft to the knife edge, such as dedicated rigid frames, may be used provided they are vertical, achieve the required level and parallel relationship, are of well-known weight and center, and achieve the required restraint of the lower component of the knife edge relative to the craft.

8. Procedure

8.1 *Safety*—First and foremost, throughout the entire air inclining procedure, it is advised NOT to go under a suspended craft.

8.2 Bring the lift gear taut without lifting the craft. Verify the location and vertical measurement of the lift points, knife edges, weight locations, etc. relative to the SRP. Verify the transverse measurements of the weight shifts.

8.3 Lift the craft in the as-inclined condition with all inclining equipment aboard and set up in position and with the weights in their initial position.

8.3.1 Verify the level and parallel condition. Note the scale reading(s). Photograph the craft showing the entire craft from several views, with close up views of the weights and the scale reading(s).

8.3.2 If only one scale is used, interchange the scale and link and repeat as in accordance with 8.3.1.