

## ISO/ASTM 51631:2013(E)

## ISO/ASTM 51631 – 2020(E)



# Standard Practice for Use of Calorimetric Dosimetry Systems for Electron Beam Dose Measurements and Routine Dosimetry System Calibration in Electron Beams<sup>1</sup>

This standard is issued under the fixed designation ISO/ASTM 51631; the number immediately following the designation indicates the year of original adoption or, in the case of revision, the year of last revision.

## 1. Scope

1.1 This practice covers the preparation and use of semi-adiabatic calorimetric dosimetry systems for measurement of absorbed dose and for calibration of routine dosimetry systems when irradiated with electrons for radiation processing applications. The calorimeters are either transported by a conveyor past a scanned electron beam or are stationary in a broadened beam.

1.2 This document is one of a set of standards that provides recommendations for properly implementing dosimetry in radiation processing, and describes a means of achieving compliance with the requirements of ~~ASTM~~ISO/ASTM Practice ~~E2628~~[E2628](#)~~52628~~ for a calorimetric dosimetry system. It is intended to be read in conjunction with ~~ASTM~~ISO/ASTM Practice ~~E2628~~[E2628](#)~~52628~~.

1.3 The calorimeters described in this practice are classified as Type II dosimeters on the basis of the complex effect of influence quantities. See ~~ASTM~~ISO/ASTM Practice ~~E2628~~[E2628](#)~~52628~~.

1.4 This practice applies to electron beams in the energy range from 1.5 to 12 MeV.

1.5 The absorbed dose range depends on the calorimetric absorbing material and the irradiation and measurement conditions. Minimum dose is approximately 100 Gy and maximum dose is approximately 50 kGy.

1.6 The average absorbed-dose rate shall generally be greater than 10 Gy·s<sup>-1</sup>.

1.7 The temperature range for use of these calorimetric dosimetry systems depends on the thermal resistance of the calorimetric materials, on the calibrated calibration range of the temperature sensor, and on the sensitivity of the measurement device.

1.8 *This standard does not purport to address all of the safety concerns, if any, associated with its use. It is the responsibility of the user of this standard to establish appropriate safety, health, and ~~health~~environmental practices and determine the applicability of regulatory limitations prior to use.*

1.9 *This international standard was developed in accordance with internationally recognized principles on standardization established in the Decision on Principles for the Development of International Standards, Guides and Recommendations issued by the World Trade Organization Technical Barriers to Trade (TBT) Committee.*

## 2. Referenced Documents

### 2.1 ASTM Standards:<sup>2</sup>

~~E170 Terminology Relating to Radiation Measurements and Dosimetry~~

~~E666 Practice for Calculating Absorbed Dose From Gamma or X Radiation~~

~~E668 Practice for Application of Thermoluminescence-Dosimetry (TLD) Systems for Determining Absorbed Dose in Radiation-Hardness Testing of Electronic Devices~~

~~E2628~~[E3083 Practice for Dosimetry in Radiation Processing](#)~~Terminology Relating to Radiation Processing: Dosimetry and Applications~~

~~E2701 Guide for Performance Characterization of Dosimeters and Dosimetry Systems for Use in Radiation Processing~~

<sup>1</sup> This practice is under the jurisdiction of ASTM Committee E61 on Radiation Processing and is the direct responsibility of Subcommittee E61.02 on Dosimetry Systems, and is also under the jurisdiction of ISO/TC 85/WG 3.

Current edition approved Aug. 16, 2012Jan. 15, 2020. Published April 2013February 2020. Originally published as E 1631 – 94. ASTM E 1631 – 96The present<sup>E1</sup> was adopted by ISO in 1998 with the intermediate designation ISO 15568:1998(E). The present Fourth Edition of International Standard ISO/ASTM 51631:2013(E) replaces ISO 15568 and 51631:2020(E) is a major revision of the last previous edition ISO/ASTM 51631–2003(E). Third Edition of ISO/ASTM 51631–2013(E).

<sup>2</sup> For referenced ASTM and ISO/ASTM standards, visit the ASTM website, www.astm.org, or contact ASTM Customer Service at service@astm.org. For *Annual Book of ASTM Standards* volume information, refer to the standard's Document Summary page on the ASTM website.

## 2.2 ISO/ASTM Standards:<sup>2</sup>

[51261 Practice for Calibration of Routine Dosimetry Systems for Radiation Processing](#)

~~[51431 Practice for Dosimetry in Electron and X-Ray \(Bremsstrahlung\) Irradiation Facilities for Food Processing](#)~~

[51649 Practice for Dosimetry in an Electron Beam Facility for Radiation Processing at Energies Between 300 keV and 25 MeV](#)

[51707 Guide for Estimating Uncertainties in Dosimetry for Radiation Processing](#)

[52628 Practice for Dosimetry in Radiation Processing](#)

## 2.3 International Commission on Radiation Units and Measurements (ICRU) Reports:<sup>3</sup>

[ICRU Report 34 The Dosimetry of Pulsed Radiation](#)

[ICRU Report 35 Radiation Dosimetry: Electron Beams with Energies Between 1 and 50 MeV](#)

~~[ICRU Report 37 Stopping Powers for Electrons and Positrons](#)~~

~~[ICRU Report 44 Tissue Substitutes in Radiation Dosimetry and Measurements](#)~~

[ICRU Report 80 Dosimetry Systems for use in Radiation Processing](#)

[ICRU Report 85a Fundamental Quantities and Units for Ionizing Radiation](#)

## 2.4 Joint Committee for Guides in Metrology (JCGM) Reports:

[JCGM 100:2008, GUM-1995, 1995, with minor corrections, Evaluation of measurement data – Guide to the Expression of Uncertainty in Measurement](#)<sup>4</sup>

[JCGM 200:2012, VIM International vocabulary of metrology – Basic general concepts and general terms](#)<sup>5</sup>

## 3. Terminology

### 3.1 Definitions:

3.1.1 *primary-standard dosimetry system*—dosimetry system that is designated or widely acknowledged as having the highest metrological qualities and whose value is accepted without reference to other standards of the same quantity.

3.1.2 *reference standard dosimetry system*—dosimetry system, generally having the highest metrological quality available at a given location or in a given organization, from which measurements made there are derived.

3.1.3 *transfer standard dosimetry system*—dosimetry system used as an intermediary to calibrate other dosimetry systems.

3.1.4 *type II dosimeter*—dosimeter, the response of which is affected by influence quantities in a complex way that cannot practically be expressed in terms of independent correction factors.

### 3.2 Definitions of Terms Specific to This Standard:

3.2.1 *adiabatic*—no heat exchange with the surroundings.

3.2.2 *calorimeter*—assembly consisting of calorimetric body (absorber), thermal insulation, and temperature sensor with ~~wiring; wiring that, when irradiated, exhibits increase in the absorber temperature that can be related to absorbed dose. This language parallels that of dosimeter.~~

3.2.3 *calorimetric body*—mass of material absorbing radiation energy and whose temperature is measured.

3.2.4 *calorimetric dosimetry system*—dosimetry system consisting of calorimeter, measurement instruments and their associated reference standards, and procedures for the system's use.

3.2.5 *endothermic reaction*—chemical reaction that consumes energy.

3.2.6 *exothermic reaction*—chemical reaction that releases energy.

3.2.7 *heat defect (thermal defect)*—amount of energy released or consumed by chemical reactions caused by the absorption of radiation energy.

3.2.8 *specific heat capacity*—amount of energy required to raise 1 kg of material by the temperature of 1 K.

3.2.9 *thermistor*—electrical resistor with a well-defined relationship between resistance and ~~temperature; temperature of the thermistor.~~

3.2.10 *thermocouple*—junction of two metals producing an electrical voltage with a well-defined relationship to junction temperature.

3.3 Definitions of other terms used in this standard that pertain to radiation measurement and dosimetry may be found in ASTM Terminology [E170E3083](#). Definitions in [E170E3083](#) are compatible with ICRU Report 85a; that document, therefore, may be used as an alternative reference.

<sup>3</sup> Available from the Commission on Radiation Units and Measurements, 7910 Woodmont Ave., Suite 800, Bethesda, MD 20814, U.S.A.

<sup>4</sup> Document produced by Working Group 1 of the Joint Committee for Guides in Metrology (JCGM/WG 1). Available free of charge at the BIPM website (<http://www.bipm.org>).

<sup>5</sup> Document produced by Working Group 2 of the Joint Committee for Guides in Metrology (JCGM/WG 2). Available free of charge at the BIPM website (<http://www.bipm.org>).

#### 4. Significance and use

4.1 This practice is applicable to the use of calorimetric dosimetry systems for the measurement of absorbed dose in electron beams, the qualification of electron irradiation facilities, periodic checks of operating parameters of electron irradiation facilities, and calibration of other dosimetry systems in electron beams. Calorimetric dosimetry systems are most suitable for dose measurement at electron accelerators irradiation facilities utilizing conveyor systems for transport of product during irradiation.

NOTE 1—For additional information on calorimetric dosimetry system operation and use, see ICRU Report 80. For additional information on the use of dosimetry in electron accelerator facilities, see ISO/ASTM Practices ~~51431~~ and ~~51649~~, and ICRU Reports 34 and 35, and Refs **(1-3)**.<sup>6</sup>

4.2 The calorimetric dosimetry systems described in this practice are not primary standard dosimetry systems. The calorimeters are classified as Type II dosimeters (~~ASTM(ISO/ASTM E2628)~~~~52628~~). They ~~may~~might be used as internal standards at an electron beam irradiation facility, including being used as transfer standard dosimetry systems for calibration of other dosimetry systems, or they ~~may~~might be used as routine dosimeters. The calorimetric dosimetry systems are calibrated by comparison with ~~transfer-standard~~transfer standard dosimeters.

4.3 The dose measurement is based on the measurement of the temperature rise (dosimeter response) in an absorber (calorimetric body) irradiated by an electron beam. Different absorbing materials are used, but the response is usually defined in terms of dose to water.

NOTE 2—The calorimetric bodies of the calorimeters described in this practice are made from low atomic number materials. The electron fluences within these calorimetric bodies are almost independent of energy when irradiated with electron beams of 1.5 MeV or higher, and the mass collision stopping powers are approximately the same for these materials.

4.4 The absorbed dose in other materials irradiated under equivalent conditions ~~may~~can be calculated. Procedures for making such calculations are given in ASTM Practices **E666** and **E668**, and Ref **(1)**.

4.4.1 Calorimeters for use at industrial electron accelerators have been constructed using graphite, polystyrene or a Petri dish filled with water as the calorimetric body (**4-10**). The thickness of the calorimetric body ~~shall~~should be less than the range of the incident electrons.

4.4.2 Polymeric materials other than polystyrene ~~may~~might also be used for calorimetric measurements. Polystyrene is used because it is known to be resistant to radiation (**11**) and because almost no exo- or endothermic reactions take place (**12**).

#### 5. Interferences

5.1 *Extrapolation*—The calorimetric dosimetry systems described in this practice are not adiabatic, because of the exchange of heat with the surroundings or within the calorimeter assembly. The maximum temperature reached by the calorimetric body is different from the temperature that would have been reached in the absence of that heat exchange. The temperature drifts before and after irradiation ~~are~~should be extrapolated to the midpoint of the irradiation period in order to determine the true temperature increase due to the absorbed dose.

5.2 *Heat Defect*—Chemical reactions in irradiated material (resulting in what is called the heat defect or thermal defect) ~~may~~might be endo- or exothermic and ~~may~~might lead to measurable temperature changes (**3**).

5.3 *Specific Heat Capacity*—The specific heat capacity of some materials used as a calorimetric body ~~may~~might change with accumulated absorbed dose, thereby affecting the response of the calorimeters. This is notably the case for polymers, such as polystyrene, and it will therefore be necessary to recalibrate calorimetric dosimetry systems at intervals that will depend on the total accumulated dose.

NOTE 3—For calorimeters using polystyrene as material for the calorimetric body, the change in specific heat capacity might be in the order of 1 % per accumulated dose of 1 MGy. It can therefore be useful to track accumulated dose for polystyrene calorimeters.

5.4 *Influence Quantities*—The response of the calorimetric dosimetry systems to absorbed dose does not depend on ~~environmental~~ambient relative humidity and temperature.

5.5 *Temperature Effects from Accelerator Structure*—The calorimeters are often irradiated on a conveyor used for passing products and samples through the irradiation zone. ~~Radiated~~Recognizing that the thermal insulation around the calorimetric body is not perfect, there is possibility that, for example, radiated heat from the mechanical structures of the irradiation facility and from the conveyor ~~may~~might contribute to the measured temperature increase in the calorimeters.

5.6 *Thermal Equilibrium*—The most reproducible results are obtained when the calorimeters are in thermal equilibrium with their surroundings before irradiation.

5.7 *Other Foreign Materials*—The temperature sensors, wires, etc. of the calorimeter represent foreign materials, which ~~may~~might influence the temperature rise of the calorimetric body. These components should be as small as possible.

5.8 *Dose Gradients*—Dose gradients will exist within the calorimetric body when it is irradiated with electrons. These gradients must be taken into account, for example, when other dosimeters are calibrated by comparison with calorimetric dosimetry systems.

<sup>6</sup> The boldface numbers in parentheses refer to the bibliography at the end of this practice.

## 6. Apparatus

6.1 A *Typical Graphite Calorimeter* is a disc of graphite placed in a ~~thermally-insulating~~ thermally insulating material such as foamed plastic (4-6). A calibrated thermistor or thermocouple is embedded inside the disc. Some typical examples of graphite disc thicknesses and masses are listed in ~~Table 1~~ Annex A2 (2).

6.2 A *Typical Water Calorimeter* is a sealed polystyrene Petri dish filled with water and placed in ~~thermally-insulating~~ thermally insulating foamed plastic (4). A calibrated temperature sensor (thermistor) is placed through the side of the dish into the water. The shape and size of the water calorimeter can be similar to the shape and size of the polystyrene calorimeter (see 6.3).

6.3 A *Typical Polystyrene Calorimeter* is a polystyrene disc placed in ~~thermally-insulating~~ thermally insulating foamed plastic. A calibrated thermistor or thermocouple is imbedded inside the disc. The dimension of the polystyrene disc ~~may~~ might be similar to that of the graphite and water calorimeters (9). See Fig. 1 as an example of a 10-MeV-calorimeter. ~~Fig. 2~~ shows an example of a polystyrene calorimeter designed for use at 1.5 to 4-10 MeV electron accelerators: irradiation (13).

6.4 The thickness of the calorimetric body should be less than the range of the irradiating electrons, typically not exceeding  $\frac{1}{3}$  of the range of the incident electrons. ~~That~~ This will limit the effects of variation of the dose gradients within the calorimetric body.

6.5 Radiation-resistant components should be used for the parts of the calorimeter that are exposed to the electron beam. This also applies to insulation of electrical wires.

6.6 Good thermal contact must exist between the temperature sensor and the calorimetric body. For graphite and polystyrene calorimeters, this can be assured by adding a small amount of heat-conducting compound when mounting the temperature sensor.

6.7 *Measurement*—The response of the calorimeters is the temperature rise of the calorimetric body. This temperature rise is usually registered by thermistors or thermocouples.

6.7.1 *Thermistor*—A high-precision ohm-meter can be used for measurement of thermistor resistance. The meter should have a reproducibility of better than  $\pm 0.1\%$  (~~and an accuracy =1~~) and a combined uncertainty of better than  $\pm 0.2\%$ .  $\pm 0.2\%$  ( $k=1$ ). It should preferably be equipped for four-wire type resistance measurements, especially if the thermistor resistance is less than 10 k $\Omega$ . With the four-wire measurement technique, the effects of resistance in the measurement wires and electrical contacts are minimized.

6.7.2 Other appropriate instrumentation may be used for the thermistor resistance measurement, for example, a resistance bridge or commercially calibrated thermistor readers (5). It is important for both ohm-meters and resistance bridge measurements to minimize the dissipated power in the thermistor, preferably below 0.1 mW: mW, in order to avoid self-heating of the thermistor during measurement.

6.7.3 *Thermocouple*—A high-precision digital voltmeter, or ~~commercial reader~~ other dedicated instrument (2), can be used for the measurement. The reproducibility of the voltmeter should be better than 0.1  $\mu\text{V}$ ,  $\mu\text{V}$  (~~and an accuracy =1~~), and a combined uncertainty of better than  $\pm 0.2\%$ .  $\pm 0.2\%$  ( $k=1$ ).

6.7.4 *Suppliers*—Some commercial suppliers of calorimetric dosimetry systems are listed in Annex A2A3.

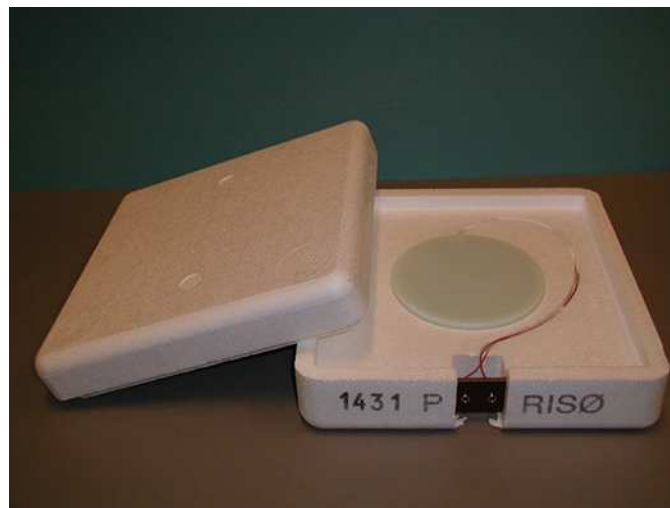

NOTE 1—All dimensions are in mm.

Courtesy of Risø High Dose Reference Laboratory.

**FIG. 1** Example of a polystyrene calorimeter used for routine measurements at a 10-MeV industrial electron accelerator

### 7. Calibration procedures

7.1 Prior to use, the calorimetric dosimetry system (consisting of calorimeter and measurement instruments) shall be calibrated in accordance with the user's documented procedure that specifies details of the calibration process and quality assurance requirements. This calibration process shall be repeated at regular intervals to ensure that the accuracy of the absorbed dose measurement is maintained within required limits. Calibration methods are described in ISO/ASTM Guide 51261.

7.2 Graphite, water or polystyrene calorimetric dosimetry systems ~~may~~should be calibrated by comparison with transfer standard dosimetry systems from an accredited calibration laboratory by irradiating the calorimeter(s) and transfer-standard dosimeters sequentially (or simultaneously) at an electron ~~accelerator~~irradiation facility. The radiation field over the cross-sectional area of the calorimetric body shall be uniform over the time required to irradiate the calorimeters and the transfer-standard dosimeters. Any non-uniformity should be taken into ~~account~~account when evaluating and comparing dose to calorimeter and dose to transfer-standard dosimeter.

7.3 It must be assured that the transfer-standard dosimeters and the calorimeters are irradiated to the same dose. Specially designed absorbers (phantoms) are needed for irradiation of the transfer-standard dosimeters, see for example Fig. 32.

7.4 The specific heat capacities of polystyrene and of graphite are functions of temperature, while the specific heat capacity of water is almost constant within the temperature range normally employed in electron beam calorimetry. The calibration curves of the calorimetric dosimetry systems are therefore expected to be functions of the average temperature of the calorimetric body (see Note 34).

7.4.1 For graphite calorimetric dosimetry systems, the calibration curve ~~may~~might take the following form:

$$Dose = (T_2 - T_1 - T_a) \cdot c_G \cdot (S_{el/\rho})_G \cdot w / (S_{el/\rho})_G \cdot k$$

$$Dose = (T_2 - T_1 - T_a) \cdot c_G \cdot (S_{el/\rho})_W / (S_{el/\rho})_G \cdot k$$

where:

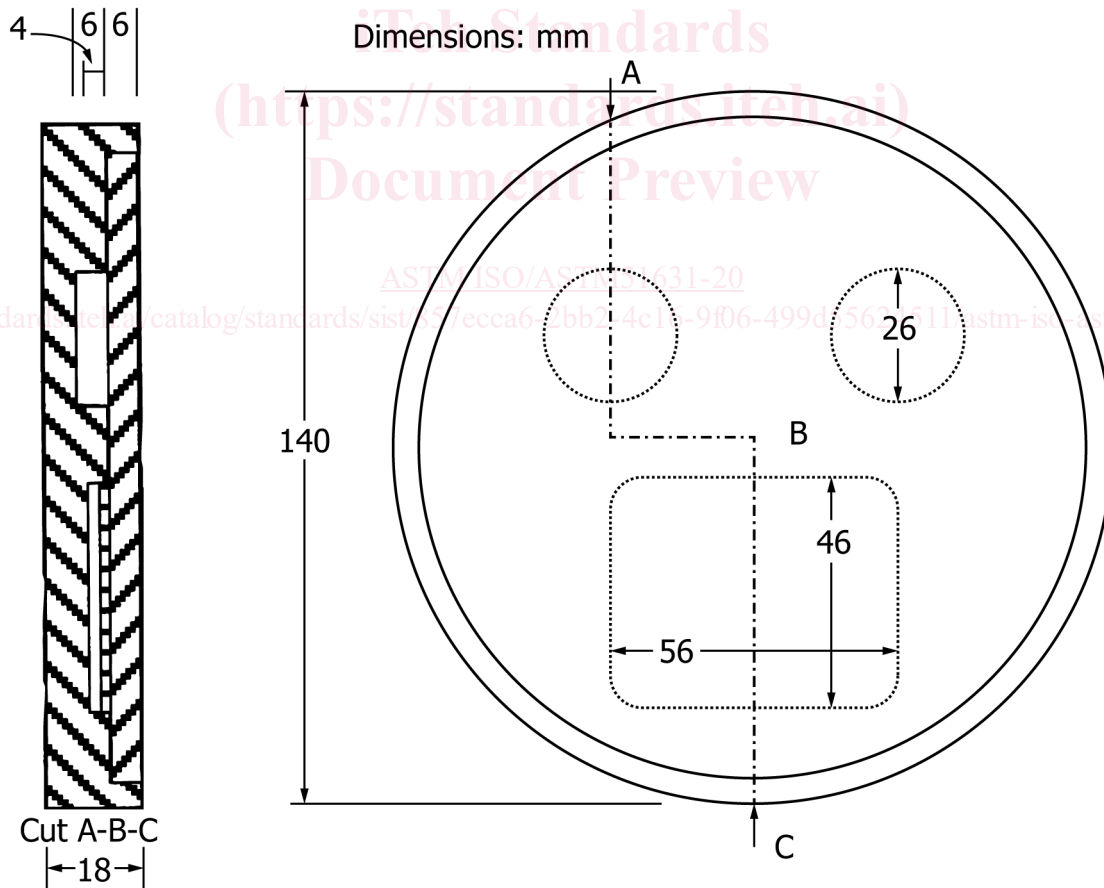

NOTE 1—All dimensions are in mm.

All dimensions are in mm. Alanine transfer standard dosimeters in cylindrical flat holders (diameter 25 mm, thickness 6 mm) to be placed in the round cut-outs. Routine dosimeters (thin film dosimeters) to be placed in rectangular cut-outs. The centres of both dosimeters are placed in the same depth in the absorber.

FIG. 32 Absorber (phantom) for irradiation at 10 MeV electron ~~accelerator~~irradiation facility of routine and transfer-standard dosimeters (10). Material: Polystyrene

- $T_1$  = temperature before irradiation,  
 $T_2$  = temperature after irradiation,  
 $T_a$  = temperature rise from irradiation facility components,  
 $c_G$  = specific heat capacity of graphite,  
 $(S_{el/\rho})_W$  and  $(S_{el/\rho})_G$  = are the electronic mass stopping powers of water and graphite, respectively, and  
 $(S_{el/\rho})_W$  = electronic mass stopping power of water,  
 $(S_{el/\rho})_G$  = electronic mass stopping power of graphite, and  
 $k$  = calibration constant to be determined during calibration verification.

NOTE 4—Repeated measurements of specific heat of various types of graphite have been carried out over the range of 0 to 50°C, indicating a value for the specific heat capacity of graphite  $c_G$  ( $J \cdot kg^{-1} \cdot ^\circ C^{-1}$ ) =  $644.2 + 2.86 T$ , where  $T$  is the mean temperature ( $^\circ C$ ) of the graphite. This value must, however, not be considered a universal value (6).

7.4.2 For polystyrene calorimetric dosimetry systems, the calibration curve may~~might~~ take the following form:

$$Dose = (T_2 - T_1 - T_a) \cdot F(T) \cdot k$$

where:

- $T_1$  = temperature before irradiation,  
 $T_2$  = temperature after irradiation,  
 $T_a$  = temperature rise from irradiation facility components,  
 $F(T)$  = function representing specific heat capacity of polystyrene, and  
 $k$  = calibration constant to be determined during calibration verification.

NOTE 5—The function  $F(T)$  takes the form  $F(T) = C1 + C2 \cdot T$ , where  $C1$  and  $C2$  are constants and  $T$  is the mean temperature ( $^\circ C$ ) of the calorimetric body-body following irradiation. The values of  $C1$  and  $C2$  depend on the type of polystyrene used for making the calorimetric absorber.

NOTE 6—~~The value of  $T_a$  depends on the facility where the calorimeter is used.  $T_a$  can be determined by passing a calorimeter through the irradiation zone shortly after the electron beam has been switched off, and measuring the temperature increase of the calorimetric absorber.~~

NOTE 7—The sensitivity of water calorimetric dosimetry systems is approximately  $3.4 \text{ kGy} \cdot ^\circ C^{-1}$  and for polystyrene calorimetric dosimetry systems it is approximately  $1.4 \text{ kGy} \cdot ^\circ C^{-1}$ . For graphite calorimetric dosimetry systems, the ~~sensitivity~~sensitivity is approximately  $0.75 \text{ kGy} \cdot ^\circ C^{-1}$ .

7.5 Calibration of all types of calorimetric dosimetry systems used as routine dosimetry systems should be ~~checked by~~verified by the user by comparison with reference standard or transfer standard dosimetry systems at a frequency determined by the user.

7.6 It is recommended that calibration of the calorimetric dosimetry system be carried out by irradiation at the user's facility in order for the effect of influence quantities to be minimized.

7.7 Calorimetric dosimetry systems ~~may~~can be calibrated by irradiation at a calibration laboratory. The calibration obtained in this way must be verified by ~~simultaneous~~simultaneous irradiation of the calorimeters and transfer-standard dosimeters together at the user's facility.

NOTE 8—Calibration curves provided by manufacturers of calorimeters are typically not obtained by irradiation at the user's facility. Such calibration curves should be verified by irradiation at the user's facility.

7.8 An example of a calibration verification of a calorimetric dosimetry system is given in [Annex A1](#).

7.9 *Measurement Instrument Calibration and Performance Verification*—For the calibration of the measuring instruments, and for the verification of instrument performance between calibrations, see ISO/ASTM Guide [51261](#) ~~and/or~~or instrument-specific operating ~~manuals~~manuals, or both.

## 8. Dose measurement procedures

8.1 *Conveyor Irradiation Off-Line Measurements*—For calorimeters carried on conveyors through scanned electron beams, the calorimeter is usually disconnected from the temperature measurement system just prior to ~~irradiation~~placing the calorimeter on the conveyor and reconnected for measurement just as soon as practical after irradiation (7).

8.1.1 Before irradiation, ~~measure~~measure the temperature of the calorimetric body ~~and check that the temperature remains stable for is~~measured. It should remain stable, typically less than 0.1°C change over a period of at least 10 min (typically less than 0.1°C change):min.

NOTE 9—It is recommended to store calorimeters in close proximity to the irradiation area, so that the calorimeters are in approximate thermal equilibrium with the conditions of the irradiation area prior to use.

8.1.2 ~~Disconnect the~~The measurement wires are disconnected and place the calorimeter is placed on the conveyor for transport through the irradiation zone.

8.1.3 ~~Transport the calorimeter~~The calorimeter is transported through the irradiation zone on the conveyor system.

8.1.4 ~~Record the~~The time of irradiation, and the irradiation parameters (for example, electron energy, electron current, scanned beam width, and conveyor speed):speed should be recorded.