



Designation: **C140/C140M – 18a** C140/C140M – 20

# Standard Test Methods for Sampling and Testing Concrete Masonry Units and Related Units<sup>1</sup>

This standard is issued under the fixed designation C140/C140M; the number immediately following the designation indicates the year of original adoption or, in the case of revision, the year of last revision. A number in parentheses indicates the year of last reapproval. A superscript epsilon ( $\epsilon$ ) indicates an editorial change since the last revision or reapproval.

*This standard has been approved for use by agencies of the U.S. Department of Defense.*

## 1. Scope\*

1.1 These test methods provide various testing procedures commonly used for evaluating characteristics of concrete masonry units and related concrete units. Methods are provided for sampling, measurement of dimensions, compressive strength, absorption, unit weight (density), moisture content, flexural load, and ballast weight. Not all methods are applicable to all unit types, however.

1.2 Specific testing and reporting procedures are included in annexes to these test methods for the following specific unit types:

- Annex A1—Concrete masonry units (Specifications C90, C129)
- Annex A2—Concrete and calcium silicate brick (Specifications C55, C73, C1634)
- Annex A3—Segmental retaining wall units (Specification C1372)
- Annex A4—Concrete interlocking paving units (Specification C936/C936M)
- Annex A5—Concrete grid paving units (Specification C1319)
- Annex A6—Concrete roof pavers (Specification C1491)
- Annex A7—Dry-cast articulating concrete block (Specification D6684)
- Annex A8—Segmental Concrete Paving Slabs (Specification C1782/C1782M)

1.3 The test procedures included in these test methods are also applicable to other types of units not referenced in these test methods, but specific testing and reporting requirements for those units are not included.

1.4 These test methods include the following sections:

	Section
Scope	1
Referenced Documents	2
Terminology	3
Significance and Use	4
Sampling	5
Measurement of Dimensions	6
Compressive Strength	7
Absorption	8
Calculations	9
Report	10
Keywords	11
Annexes—Test Procedures	
Concrete Masonry Units	Annex A1
Concrete and Calcium Silicate Brick	Annex A2
Segmental Retaining Wall Units	Annex A3
Concrete Interlocking Paving Units	Annex A4
Concrete Grid Paving Units	Annex A5
Concrete Roof Pavers	Annex A6

<sup>1</sup> These test methods are under the jurisdiction of ASTM Committee C15 on Manufactured Masonry Units and are the direct responsibility of Subcommittee C15.03 on Concrete Masonry Units and Related Units.

Current edition approved Dec. 15, 2018; Feb. 1, 2020. Published January 2019/February 2020. Originally approved in 1938. Last previous edition approved in 2018 as C140 – 18; C140 – 18a. DOI: 10.1520/C0140-C0140M-18A-10.1520/C0140\_C0140M-20.

\*A Summary of Changes section appears at the end of this standard



Dry-Cast Articulating  
Concrete Block  
Segmental Concrete Paving Slabs  
Worksheet and Test Report for  
Concrete Masonry Units

Section  
Annex A7

Annex A8  
Appendix X1

NOTE 1—The testing laboratory performing these test methods should be evaluated in accordance with Practice C1093.

1.5 The text of this test method references notes and footnotes that provide explanatory material. These notes and footnotes (excluding those in tables and figures) shall not be considered as requirements of the standard.

1.6 The values stated in either SI units or inch-pound units are to be regarded separately as standard. The values stated in each system may not be exact equivalents; therefore, each system shall be used independently of the other. Combining values from the two systems may result in non-conformance with the standard.

1.7 *This standard does not purport to address all of the safety concerns, if any, associated with its use. It is the responsibility of the user of this standard to establish appropriate safety, health, and environmental practices and determine the applicability of regulatory limitations prior to use.*

1.8 *This international standard was developed in accordance with internationally recognized principles on standardization established in the Decision on Principles for the Development of International Standards, Guides and Recommendations issued by the World Trade Organization Technical Barriers to Trade (TBT) Committee.*

## 2. Referenced Documents

### 2.1 ASTM Standards:<sup>2</sup>

C55 Specification for Concrete Building Brick

C73 Specification for Calcium Silicate Brick (Sand-Lime Brick)

C90 Specification for Loadbearing Concrete Masonry Units

C129 Specification for Nonloadbearing Concrete Masonry Units

C143/C143M Test Method for Slump of Hydraulic-Cement Concrete

C936/C936M Specification for Solid Concrete Interlocking Paving Units

C1093 Practice for Accreditation of Testing Agencies for Masonry

C1232 Terminology for Masonry

C1319 Specification for Concrete Grid Paving Units

C1372 Specification for Dry-Cast Segmental Retaining Wall Units

C1491 Specification for Concrete Roof Pavers

C1552 Practice for Capping Concrete Masonry Units, Related Units and Masonry Prisms for Compression Testing

C1634 Specification for Concrete Facing Brick

C1716/C1716M Specification for Compression Testing Machine Requirements for Concrete Masonry Units, Related Units, and Prisms

C1782/C1782M Specification for Segmental Concrete Paving Slabs

D1056 Specification for Flexible Cellular Materials—Sponge or Expanded Rubber

D6684 Specification for Materials and Manufacture of Articulating Concrete Block (ACB) Systems

E4 Practices for Force Verification of Testing Machines

E6 Terminology Relating to Methods of Mechanical Testing

### 2.2 Other Documents:

SP 960-12 NIST Recommended Practice Guide – Stopwatch and Timer Calibration<sup>3</sup>

## 3. Terminology

3.1 Terminology defined in Terminologies C1232 and E6 shall apply for these test methods.

### 3.2 Definitions of Terms Specific to This Standard:

3.2.1 *lot, n*—any number of concrete masonry units or related units, designated by the producer, of any configuration or dimension manufactured by the producer using the same materials, concrete mix design, manufacturing process, and curing method.

## 4. Significance and Use

4.1 These test methods provide general testing requirements for application to a broad range of concrete products. Those general testing requirements are included in the body of this standard.

<sup>2</sup> For referenced ASTM standards, visit the ASTM website, [www.astm.org](http://www.astm.org), or contact ASTM Customer Service at [service@astm.org](mailto:service@astm.org). For *Annual Book of ASTM Standards* volume information, refer to the standard's Document Summary page on the ASTM website.

<sup>3</sup> Available at <http://tf.nist.gov/general/pdf/2281.pdf>

NOTE 2—Consult manufacturer, supplier, product specifications, or other resources for more specific measurement or testing guidelines for those products not addressed with the annex of this standard.

4.2 These test methods provide specific testing requirements in two distinct sections, the requirements applicable to all units covered by these test methods and those applicable to the specific unit types. The requirements applicable to all units are included in the body of these test methods and those applicable to the specific unit types are included within the annexes.

## 5. Sampling

### 5.1 Selection of Test Specimens:

5.1.1 For purposes of testing, full-sized units shall be selected by the purchaser or authorized representative. The selected specimens shall be of similar configuration and dimensions. Specimens shall be representative of the whole lot of units from which they are selected.

### 5.2 Number of Specimens:

5.2.1 Unless specified otherwise in the applicable annex, a set of units shall consist of six full-size units.

5.3 Remove loose material from the specimens (including the cores) prior to determining the received weight.

NOTE 3—An abrasive stone or wire brush is typically used to remove loose material.

5.4 *Identification*—Mark each specimen so that it may be identified at any time. Markings shall cover not more than 5 % of the surface area of the specimen.

5.5 *Received Weight*—~~Weigh~~ Prior to performing tests, weigh each specimen immediately after sampling and marking, and record as  $w_r$  (received weight). Record time and place  $w_r$  was measured.

NOTE 4—Received weights often have direct relationships with other unit properties and are therefore a useful method of evaluating results or for sorting purposes. It is good laboratory practice to separate sampled units for strength and absorption testing by received weight, such that the averages of the subsets of specimens are similar and representative of the sampled units. Received weight may also be useful in evaluating inconsistency in test results or unit production issues. The weight of a concrete masonry unit and related unit changes with time and exposure conditions, primarily as a result of the moisture within the unit. Therefore, to understand the context of a received weight value, it is also important to understand the point in time and the frame of reference when that weight was determined. “Time and place” should not refer to when and where the unit was sampled but when and where the received weights were determined. In addition to date and time references, it is also important to know if those weights were determined after units reached equilibrium with lab environment, or before units were shipped, or after delivery to the job site, and so forth. Moisture content is not a physical property requirement of concrete masonry units, therefore field measurement of received weight is not necessary (unless specifically specified for a particular job).

## 6. Measurement of Dimensions

### 6.1 Apparatus:

6.1.1 *Measurement Devices*—Devices used to measure specimen dimensions shall have divisions not greater than 0.1 in. [2.5 mm] when the dimension is to be reported to the nearest 0.1 in. [2.5 mm] and not greater than 0.01 in. [0.25 mm] when the dimension is to be reported to the nearest 0.01 in. [0.25 mm].

6.1.2 Measuring devices shall be readable and accurate to the division required to be reported. Accuracy shall be verified at least once annually. Verification record shall include date of verification, person or agency performing verification, identification of reference standard used, test points used during verification, and readings at test points.

6.2 *Specimens*—Three full-size units shall be selected for measurement of dimensions.

6.3 *Measurements*—Measure specimens in accordance with the applicable annex of this standard. For those products not covered by the annexes of this standard, measure overall dimensions (width, height, length) in at least two locations on opposite sides of the specimen to the nearest division required to be reported. Document location of each measurement on a sketch or photograph of the specimen.

NOTE 5—Specimens used for measurement of dimensions may be used in other tests.

NOTE 6—Calipers, micrometers, and steel scales and dividers of the appropriate accuracy and readability have been shown to be adequate for these measurements.

## 7. Compressive Strength

7.1 *Test Apparatus*—The compressive strength testing machine shall conform to Specification **C1716/C1716M**.

NOTE 7—Previous versions of this standard have contained specific requirements for compressive strength test machines. These requirements have been replaced with reference to Specification **C1716/C1716M**.

### 7.2 Test Specimens:

7.2.1 Unless specified otherwise in the applicable annex, test three specimens in compression.

7.2.2 Unless specified otherwise in the applicable annex, specimens shall be full-sized units except when the units cannot be tested full-size due to specimen configuration or testing machine requirements. In these cases, reduce the specimen size in accordance with **Annex A1**.

7.2.3 After delivery to the laboratory, store compression specimens (unstacked and separated by not less than 0.5 in. [13 mm] on all sides) continuously in air at a temperature of  $75 \pm 15^\circ\text{F}$  [ $24 \pm 8^\circ\text{C}$ ] and a relative humidity of less than 80 % for not less than 48 h. Alternatively, if compression results are required sooner, store units unstacked in the same environment described above with a current of air from an electric fan passing over them for a period of not less than 4 h. Continue passing air over the specimens until two successive weighings at intervals of 2 h show an increment of loss not greater than 0.2 % of the previously determined weight of the specimen and until no moisture or dampness is visible on any surface of the unit. Specimens shall not be subjected to oven-drying.

NOTE 8—In this test method, net area (other than certain solid units, see 9.5) is determined from specimens other than those subjected to compression testing. The compressive strength method is based on the assumption that units used for determining net volume (absorption specimens) have the same net volume as units used for compression testing. Sampled split face units, which have irregular surfaces, should be divided at the time they are sampled from the lot, such that the absorption test specimens have a net volume that is visually representative and a weight that is representative of the compression test specimens.

7.2.4 Where saw-cutting of test specimens is allowed or required by the standard or applicable annex, sawing shall be performed in an accurate, competent manner, subjecting the specimen to as little saw vibration as possible. Use a diamond saw blade of proper hardness. Following cutting, residue from the cutting operation shall be removed prior to continuing testing (see Note 9). If the specimen is wetted during sawing, allow the specimen to dry to equilibrium with laboratory air conditions before testing, using the procedures outlined in 7.2.3.

NOTE 9—For specimens cut with a wet saw, rinsing with clean water is typically sufficient for removing cutting residue. For specimens cut with a dry saw, brushing with a soft-bristle brush is typically sufficient for removing cutting residue.

7.2.5 If compression test specimens have been saw-cut from full-sized units and the net area of the compression test specimens can not be determined by 9.5.1, saw-cut an additional three units to the dimensions and configuration of the three compression test specimens. The average net area for the saw-cut compression specimens shall be taken as the average net area of the additional three saw-cut units calculated as required in 9.5. Calculated net volumes of saw-cut specimens shall not be used in calculating equivalent thickness.

7.3 *Capping*—Cap test specimens in accordance with Practice C1552.

7.4 *Compression Testing Procedure:*

7.4.1 *Position of Specimens*—Test specimens with the centroid of their bearing surfaces aligned vertically with the center of thrust of the spherically seated steel bearing block of the testing machine (Note 10). Except for special units intended for use with their cores in a horizontal direction, test all hollow concrete masonry units with their cores in a vertical direction. Test masonry units that are 100 % solid and special hollow units intended for use with their hollow cores in a horizontal direction in the same direction as in service. Prior to testing each unit, ensure that the upper platen moves freely within its spherical seat to attain uniform seating during testing.

NOTE 10—For those masonry units that are symmetrical about an axis, the location of that axis can be determined geometrically by dividing the dimension perpendicular to that axis (but in the same plane) by two. For those masonry units that are nonsymmetrical about an axis, the location of that axis can be determined by balancing the masonry unit on a knife edge or a metal rod placed parallel to that axis. If a metal rod is used, the rod shall be straight, cylindrical (able to roll freely on a flat surface), have a diameter of not less than 0.25 in. [6 mm] and not more than 0.75 in. [19 mm], and its length shall be sufficient to extend past each end of the specimen when placed upon it. The metal rod shall be placed on a smooth, flat, level surface. Once determined, the centroidal axis shall be marked on the end of the unit using a pencil or marker having a marking width of not greater than 0.05 in. [1.5 mm]. A tamping rod used for consolidation of concrete and grout for slump tests performed in accordance with Test Method C143/C143M is often used as a balancing rod.

7.4.2 *Moisture Condition of Specimens*—At the time the specimens are tested, they shall be free of visible moisture or dampness.

7.4.3 *Speed of Testing*—Apply the load (up to one half of the expected maximum load) at any convenient rate, after which adjust the controls of the machine as required to give a uniform rate of travel of the moving head such that the remaining load is applied in not less than 1 nor more than 2 min. The results of the first specimen shall not be discarded so long as the actual loading time for the second half of the actual load is greater than 30 s.

NOTE 11—The allowance for a loading rate outside of 1 to 2 min for the first specimen acknowledges that the expected load may be different than the actual maximum load. The load rate for the remaining two specimens should be adjusted based on the first specimen results.

7.4.4 *Maximum Load*—Record the maximum compressive load in pounds [newtons] as  $P_{max}$ .

## 8. Absorption

8.1 *Apparatus*—Unless specified otherwise in the appropriate annex, the following equipment shall be used:

8.1.1 *Balance*—A balance readable and accurate to 0.1 % of the weight of the smallest specimen tested. Balances shall be calibrated in accordance with Practice C1093.

8.1.2 *Oven*—A ventilated oven of appropriate size capable of maintaining a uniform temperature of  $230 \pm 9^\circ\text{F}$  [ $110 \pm 5^\circ\text{C}$ ]. Ovens shall be verified in accordance with Practice C1093.

8.1.3 *Timer*—A timer readable and accurate to 1 second. Timers shall be verified in accordance with Practice C1093. (See Note 12.)

NOTE 12—Recommended procedures for verifying timers can be found in NIST Special Publication 960-12 (2009): NIST Recommended Practice Guide—Stopwatch and Timer Calibrations.

## 8.2 Test Specimens:

8.2.1 Unless specified otherwise in the applicable annex, test three specimens in absorption.

8.2.2 Unless specified otherwise in the applicable annex, tests shall be performed on full-sized units or specimens saw-cut from full-sized units. Calculated values for absorption and density of reduced-size absorption specimens shall be considered as representative of the whole unit.

8.2.2.1 When test specimens are saw-cut from full-sized units, the test specimen shall have an initial weight after cutting of no less than 20 % of the initial received weight of the full-sized unit.

NOTE 13—When performing absorption tests on reduced-sized specimens, it is preferable to have a test specimen that is as large as practically possible and can be accommodated by laboratory equipment. This helps to reduce any location-specific variability from the absorption results.

## 8.3 Procedure:

8.3.1 Immerse the test specimens in water at a temperature of 60 to 80°F [15 to 27°C] for 24 to 28 h such that the top surfaces of the specimens are at least 6 in. [150 mm] below the surface of the water. Specimens shall be separated from each other and from the bottom of the immersion tank by at least 0.125 in. [3 mm], using wire mesh, grating, or other spacers. The spacer shall not cover more than 10 % of the area of the face that is in direct contact with the spacer (see Note 14).

NOTE 14—The intent of the requirement for spacer contact with the specimen surface is to limit the possibility of reduced absorption of water due to blockage by the spacer. In order to determine compliance, only the area of the surface of the specimen in contact with the spacer should be considered. For example, when a spacer is used between the bottom of the specimen and the bottom of the tank, only the area of the bottom of the unit should be used to determine the 10 % limit (not the surface area of the entire specimen).

8.3.2 Weigh the specimens while suspended by a metal wire and completely submerged in water and record  $w_i$  (immersed weight).

8.3.3 Remove the specimens from water and allow to drain by placing them on a 0.375-in. [10-mm] or coarser wire mesh. While the specimen is draining and before weighing, remove visible surface water with a damp cloth. Weigh specimens  $60 \pm 5$  s following removal from water. Record as  $w_s$  (saturated weight).

8.3.4 Subsequent to saturation, dry all specimens in a ventilated oven at  $230 \pm 9^\circ\text{F}$  [ $110 \pm 5^\circ\text{C}$ ] for not less than 24 h and until two successive weighings at intervals of 2 h show an increment of loss not greater than 0.2 % of the last previously determined weight of the specimen. Record weight of dried specimens as  $w_d$  (oven-dry weight).

## 9. Calculations

9.1 *Absorption*—Calculate absorption as follows:

$$\text{Absorption, lb/ft}^3 = [(w_s - w_d)/(w_s + w_i)] \times 62.4 \quad (1)$$

$$[\text{Absorption, kg/m}^3 = [(w_s - w_d)/(w_s - w_i)] \times 1000]$$

$$\text{Absorption, \%} = [(w_s - w_d)/w_d] \times 100$$

where:

$w_s$  = saturated weight of specimen, lb [kg],  
 $w_i$  = immersed weight of specimen, lb [kg], and  
 $w_d$  = oven-dry weight of specimen, lb [kg].

9.2 *Moisture Content*—Calculate the moisture content of the unit at the time it is sampled (when  $w_r$  is measured) as follows:

$$\text{Moisture Content, \% of total absorption} = [(w_r - w_d)/(w_s - w_d)] \times 100 \quad (2)$$

where:

$w_r$  = received weight of unit, lb [kg],  
 $w_d$  = oven-dry weight of unit, lb [kg], and  
 $w_s$  = saturated weight of unit, lb [kg].

NOTE 15—When determining the moisture content of a unit or set of units, the value determined is a measure of the water content of a unit based upon the received weight of the unit  $w_r$ . Thus, the moisture content calculation above is only applicable to the unit moisture content at the time the received weight,  $w_r$ , is obtained.

9.3 *Density*—Calculate oven-dry density as follows:

$$\text{Density (D), lb/ft}^3 = [w_d / (w_s - w_i)] \times 62.4 \quad (3)$$

$$[\text{Density (D), kg/m}^3 = [w_d / (w_s - w_i)] \times 1000]$$

where:

$w_d$  = oven-dry weight of specimen, lb [kg],  
 $w_s$  = saturated weight of specimen, lb [kg], and  
 $w_i$  = immersed weight of specimen, lb [kg].

9.4 *Net Volume*—Calculate net volume as follows:

$$\text{Net Volume } (V_n), \text{ ft}^3 = w_d/D = (w_s - w_i)/62.4 \quad (4)$$

$$[\text{Net Volume } (V_n), \text{ cm}^3 = (w_d/D) \times 10^6 = (w_s - w_i) \times 10^3]$$

where:

$V_n$  = net volume of specimen, ft<sup>3</sup> [cm<sup>3</sup>],  
 $w_d$  = oven-dry weight of specimen, lb [kg],  
 $D$  = oven-dry density of specimen, lb/ft<sup>3</sup> [kg/m<sup>3</sup>],  
 $w_s$  = saturated weight of specimen, lb [kg], and  
 $w_i$  = immersed weight of specimen, lb [kg].

9.5 *Average Net Area*—Calculate net area as follows:

$$\text{Average Net Area } (A_n), \text{ in.}^2 = (V_n \times 1728)/H \quad (5)$$

$$[\text{Average Net Area } (A_n), \text{ mm}^2 = (V_n \times 10^3)/H]$$

where:

$V_n$  = net volume of specimen, ft<sup>3</sup> [cm<sup>3</sup>],  
 $A_n$  = average net area of specimen, in.<sup>2</sup> [mm<sup>2</sup>], and  
 $H$  = average height of specimen, in. [mm].

NOTE 16—In SI units, net volume is calculated in terms of cubic centimetres to be consistent with the reporting requirements of this standard. Net area, however, is calculated in terms of square millimetres in order to facilitate calculation of compressive strength in MPa which is defined as N/mm<sup>2</sup>.

9.5.1 Except for irregularly shaped specimens, such as those with split surfaces, calculate the net area of coupons and those specimens whose net cross-sectional area in every plane parallel to the bearing surface is equal to the gross cross-sectional area measured in the same plane, as follows:

$$\text{Net Area } (A_n), \text{ in.}^2 [\text{mm}^2] = L \times W \quad (6)$$

where:

$A_n$  = net area of coupon or specimen, in.<sup>2</sup> [mm<sup>2</sup>],  
 $L$  = average length of coupon or specimen, in. [mm], and  
 $W$  = average width of coupon or specimen, in. [mm].

9.6 *Gross Area*—Calculate gross area of each specimen as follows:

$$\text{Gross Area } (A_g), \text{ in.}^2 [\text{mm}^2] = L \times W \quad (7)$$

where:

$A_g$  = gross area of specimen, in.<sup>2</sup> [mm<sup>2</sup>],  
 $L$  = average length of specimen, in. [mm], and  
 $W$  = average width of specimen, in. [mm].

9.6.1 The gross cross-sectional area of a specimen is the total area of a section perpendicular to the direction of the load, including areas within cells and reentrant spaces, unless these spaces are to be occupied in the masonry by portions of adjacent masonry.

9.7 *Compressive Strength*:

9.7.1 *Net Area Compressive Strength*—Calculate the net area compressive strength of the specimen as follows:

$$\text{Net Area Compressive Strength, psi [MPa]} = P_{max}/A_n \quad (8)$$

where:

$P_{max}$  = maximum compressive load, lb [N], and  
 $A_{n, avg}$  = average of the net area values determined for each of the three absorption specimens, in.<sup>2</sup> [mm<sup>2</sup>].

9.7.2 *Gross Area Compressive Strength*—Calculate the gross area compressive strength of the specimen as follows:

$$\text{Gross Area Compressive Strength, psi [MPa]} = P_{max}/A_g \quad (9)$$

where:

$P_{max}$  = maximum compressive load, lb [N], and

$A_{g, avg}$  = average of the gross area values determined for each of the three specimens, in.<sup>2</sup> [mm<sup>2</sup>].

## 10. Report

10.1 For the purpose of reporting test results, all observed or calculated values shall be rounded using the following procedure:

10.1.1 When the digit immediately after the last place to be retained is less than 5, retain unchanged the digit in the last place retained.

10.1.2 When the digit immediately after the last place to be retained is greater than or equal to 5, increase by 1 the digit in the last place retained.

NOTE 17—As an example, density results are required to be reported to the nearest 0.1 lb/ft<sup>3</sup> [1 kg/m<sup>3</sup>] in 10.3.7. For inch-pound units, a calculated value of 130.85 lb/ft<sup>3</sup> should be reported as 130.9 lb/ft<sup>3</sup>. For SI units, a calculated value of 2095.85 kg/m<sup>3</sup> should be reported as 2096 kg/m<sup>3</sup>.

10.2 A complete report shall include the following general information:

10.2.1 Name and address of the testing laboratory,

10.2.2 Identification of the report and the date of issue,

10.2.3 Name and address of the client or the identification of the project,

10.2.4 Description and identification of the test sample,

10.2.5 Date of receipt of the test sample,

10.2.6 Date(s) of test performance,

10.2.7 Identification of the standard test method used, including edition, and a notation of any known deviation from the test method,

10.2.8 Name of the person(s) accepting technical responsibility for the test report,

10.2.9 Age of test specimens, if known,

10.2.10 Identification of any test results obtained from another laboratory, and

10.2.11 A photograph, sketch, or description of the configuration of the unit.

10.3 Unless specified otherwise in the applicable annex, a complete report shall include the following test results for the tests performed:

10.3.1 The average width, height and length to the nearest 0.1 in. [2.5 mm] separately for each specimen and as the average for the three specimens tested.

10.3.2 The net area to the nearest 0.1 in.<sup>2</sup> [50 mm<sup>2</sup>] separately for each specimen and as the average for the three specimens tested.

10.3.3 The maximum load separately for each specimen and as the average for the three specimens tested. Record the load as indicated to the nearest 10 lb [50 N] or the minimum resolution of the test machine as used during testing, whichever is greater.

10.3.4 The net area compressive strength to the nearest 10 psi [0.1 MPa] separately for each specimen and as the average for the three specimens tested.

10.3.5 The immersed, saturated, and oven dry weights ( $w_i$ ,  $w_s$ , and  $w_d$ ) to the nearest 0.1 lb [0.05 kg] separately for each specimen and as the average for the three specimens tested.

10.3.6 The absorption to the nearest 0.1 lb/ft<sup>3</sup> [1 kg/m<sup>3</sup>] separately for each specimen and as the average for the three specimens tested.

10.3.7 The density to the nearest 0.1 lb/ft<sup>3</sup> [1 kg/m<sup>3</sup>] separately for each specimen and as the average for the three specimens tested.

10.3.8 When required, the received weight ( $w_r$ ) to the nearest 0.1 lb [0.05 kg] and the moisture content to the nearest 0.1 % separately for each specimen and as the average for the three specimens tested. The time when the moisture content is determined (when  $w_r$  is measured) shall also be reported.

10.3.9 The size and configuration of the specimens tested for compressive strength and absorption.

10.4 Provide a summary report that includes the information necessary to determine compliance with the applicable product specification for the properties evaluated.

10.5 A complete report shall also include the other reporting requirements from the applicable annex.

NOTE 18—This summary report can be included as part of the test report or provided separately as a cover letter. See Appendix X1 for an example of a test report with summary section for concrete masonry units.

## 11. Keywords

11.1 absorption; compressive strength; concrete masonry units; density; equivalent thickness; face shell; moisture content; roof paver; web area; webs; web thickness

ANNEXES

(Mandatory Information)

A1. TEST PROCEDURES FOR CONCRETE MASONRY UNITS

A1.1 Scope

A1.1.1 This annex includes testing requirements that are particular for concrete masonry units that are manufactured for compliance with the following unit specifications: C90, C129.

A1.2 Measurement

A1.2.1 For each unit, measure and record the following to the nearest division required to be reported (see Fig. A1.1):

- (1) Width ( $W$ ) at mid-length across the top and bottom bearing surfaces. Average the two recorded values to determine the width of the specimen.
- (2) Height ( $H$ ) at mid-length on each face. Average the two recorded values to determine the height of the specimen.
- (3) Length ( $L$ ) at mid-height on each face. Average the two recorded values to determine the length of the specimen.

A1.2.2 For each unit, measure the face shell thicknesses ( $t_{fs}$ ) at the thinnest point 0.50 in. [13 mm] down from the top surface of the unit as manufactured (typically the bottom surface of the unit as laid) and record to the nearest division required to be reported. Disregard grooves, scores, and similar details in the face shell thickness measurements.

A1.2.3 For each unit, when the thinnest point of opposite face shells differ in thickness by less than 0.125 in. [3 mm], calculate the minimum face shell thickness by averaging the recorded measurements. When the thinnest points differ by more than 0.125 in. [3 mm], the minimum face shell thickness shall be taken as the smaller of the two recorded measurements.

A1.2.4 For each unit, measure the web thickness ( $t_w$ ) at the minimum thickness of each web to the nearest 0.01 in. [0.25 mm].

A1.2.5 For each unit, determine the minimum web area using one of the following methods:

A1.2.5.1 For units with rectangular webs, measure the web height ( $t_h$ ) at the minimum height of each web to the nearest 0.1 in. [2.5 mm]. For each unit, calculate the minimum web area for each web ( $A_w$ ) by multiplying the minimum web thickness ( $t_w$ ) and minimum web height ( $t_h$ ) for measured web dimensions of 0.75 in. [19 mm] or greater. For each unit, calculate the total minimum web area ( $A_{wt}$ ) by summing the web area ( $A_w$ ) of each web.

A1.2.5.2 For units with webs that are not rectangular, disregard portions of the web that have a thickness of less than 0.75 in. [19

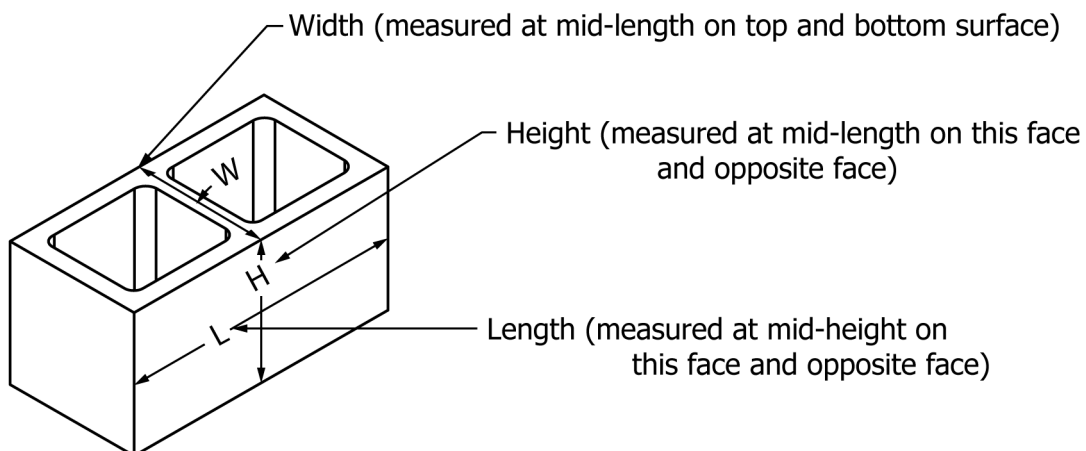

FIG. A1.1 Diagram Showing Location of Measurements for CMU



mm]. Make necessary measurements to determine the web area of each web at the minimum area based on the configuration of the web (see **Note A1.2**). For each unit, calculate the total minimum web area ( $A_{wt}$ ) by summing the web area ( $A_w$ ) of each web.

**NOTE A1.1**—Webs with minimum heights over their entire length or thickness over their entire height of less than 0.75 in. [19 mm] do not typically contribute to the unit's structural stability. Such webs should not be included in the minimum web area calculation. When a web has a portion that is less than 0.75 in. [19 mm] in thickness, the web area should be determined based only on the portions of the web that are larger than 0.75 in. [19 mm] in thickness. See **Fig. A1.2** and **Fig. A1.3**.

**NOTE A1.2**—It can be difficult on some units to access the minimum web area. If necessary, the unit can be saw-cut along the length at the minimum web area to facilitate measurements. **Fig. A1.3** shows an example of a non-rectangular web, where the upper portion would be discarded from the measurement because it is less than 0.75 in. [19 mm] in thickness, and the lower portion would be used to determine web area because it is greater than 0.75 in. [19 mm] in thickness.

### A1.3 Compressive Strength Testing

**A1.3.1 Test Specimens**—Specimens shall be full-sized units unless full-size units cannot be tested due to specimen configuration or testing machine requirements. When necessary, modify specimens as required in **A1.3.1.1** through **A1.3.1.3**.

**A1.3.1.1** Unsupported projections having a length greater than the thickness of the projection shall be removed by saw-cutting. For units with recessed webs, the face shell projecting above the web shall be removed by saw-cutting to provide a full bearing surface over the net cross section of the unit. Where the resulting unit height would be reduced by more than one-third of the original unit height, the unit shall be coupon tested in accordance with **A1.3.1.3**.

**A1.3.1.2** When compression testing full-sized units that are too large for the test machine's bearing block and platens or are beyond the load capacity of the test machine, saw-cut the units to properly size them to conform to the capabilities of the testing machine. The resulting specimen shall have no face shell projections or irregular webs and shall be fully enclosed in a four-sided cell or cells. The compressive strength of the segment shall be considered to be the compressive strength of the whole unit.

**A1.3.1.3** When compression testing units of unusual size and shape where a suitable reduced-size specimen in accordance with **A1.3.1.2** cannot be obtained, (see **Note A1.3** and **Note A1.4**), the specimens shall be saw-cut to remove any face shell projections. The resulting specimen shall be a cell or cells containing four sides that will ensure a 100 % bearing surface. Where saw-cutting will not result in an enclosed four-sided unit, the specimen shall be a coupon cut from a face shell of each unit. The coupon shall be cut from the unit such that the coupon height dimension is in the same direction as the unit's height dimension. The compressive strength of the coupon shall be the net area compressive strength of the whole unit. The coupon size shall conform with the following:

- (1) Targeted coupon width shall be equal to the face shell thickness and shall not be less than 0.75 in. [19 mm].
- (2) Targeted aspect ratio (height divided by width,  $H_s/W_s$ ) of 2.0 before capping.
- (3) Targeted length to width ratio ( $L_s/W_s$ ) of 4.0.
- (4) Actual coupon dimensions shall not differ by more than 0.12 in. [3 mm] from targeted dimensions.
- (5) Coupons shall be solid and not contain voids.

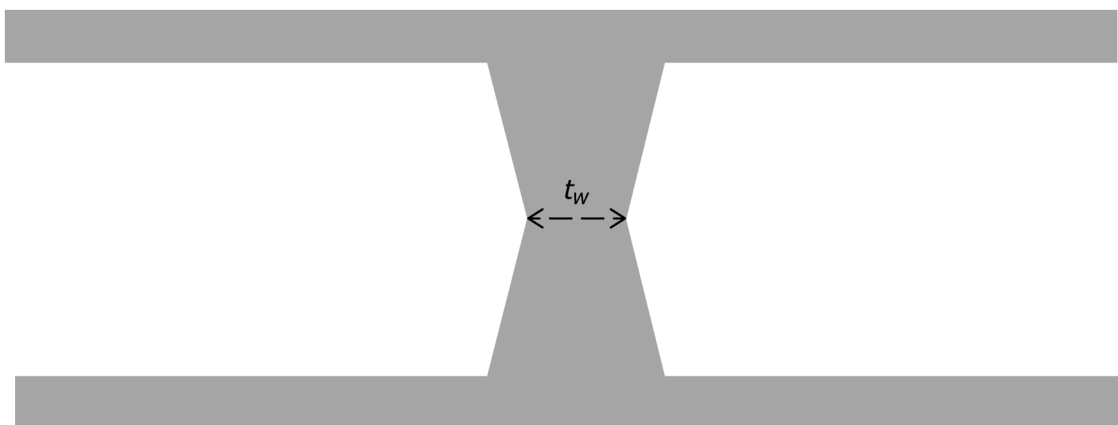

**NOTE 1**—If  $t_w$  is less than 0.75 in. [19 mm] over the entire height of the web, disregard entire area of that web when determining minimum web area.

**FIG. A1.2 Example of Web with Irregular Cross-section—Plan View**

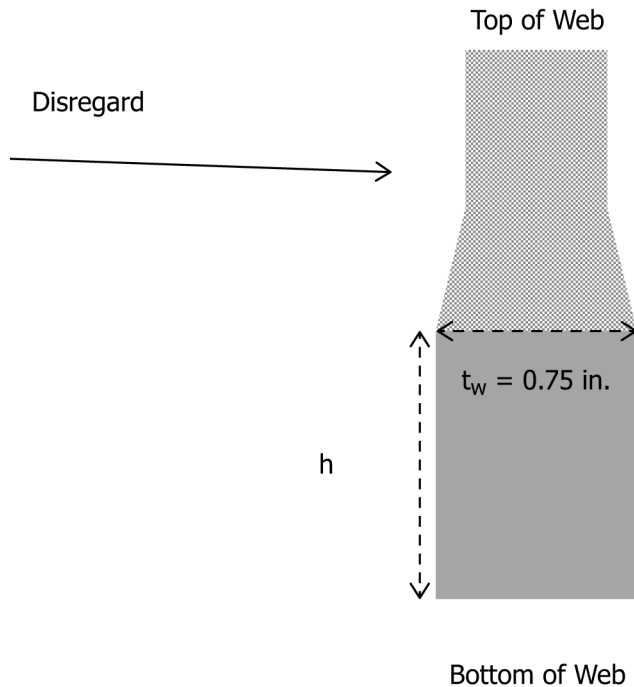

NOTE 1—Web Area =  $t_w * h$

FIG. A1.3 Example of Irregular Web Area Calculation—Section View

A1.3.1.4 If a coupon complying with to A1.3.1.3 is used for compressive strength testing, measure the coupons in accordance with A1.3.2.

A1.3.2 *Coupon Measurement*—Coupon measurements shall be performed to the nearest 0.01 in. [0.25 mm] using a measurement device readable and accurate to 0.01 in. [0.25 mm]. Measurements shall be taken as follows:

A1.3.2.1 *Width*—Measure and record the width of the coupon ( $W_s$ ) across the top and bottom surfaces at mid-length. Average the two recorded values to determine the width of the coupon.

A1.3.2.2 *Height*—Measure and record the height of the coupon ( $H_s$ ) at mid-length on each face. Average the two recorded values to determine the height of the coupon.

A1.3.2.3 *Length*—Measure and record the length of the coupon ( $L_s$ ) at mid-height of each face. Average the two recorded values to determine the length of the coupon

NOTE A1.3—Examples of units having unusual size or shape include, but are not limited to, bond beam units, open end units, and pilaster units.

NOTE A1.4—A full-size unit should be tested if feasible. If that is not feasible, then a reduced-size unit should be tested. If it is not feasible to test a full-size or reduced-size unit, then a coupon should be tested.

A1.3.3 *Testing*—Cap and test specimens in accordance with 7.3 and 7.4.

#### A1.4 Absorption Testing

A1.4.1 *Apparatus*—Absorption testing apparatus shall comply with 8.1.

A1.4.2 *Test Specimens*—Specimens shall be full-size or reduced-size specimens in accordance with 8.2 except as modified in A1.4.2.1.

A1.4.2.1 Tests shall be performed on full-size units when test results are to be used to determine moisture content in accordance with 9.2 or equivalent thickness in accordance with A1.5.3.

A1.4.3 *Testing*—Perform absorption tests in accordance with 8.3.

## A1.5 Calculations

A1.5.1 Calculate absorption, moisture content, density, average net area, and net area compressive strength in accordance with Section 9.

A1.5.2 *Normalized Web Area*—Calculate the normalized web area ( $A_{wn}$ ) of each unit by dividing the total minimum web area ( $A_{wt}$ ) by the nominal length and height of the unit as follows:

$$A_{wn}(\text{in.}^2/\text{ft}^2) = \frac{A_{wt}}{(L_n \times H_n)} \times 144 \quad (\text{A1.1})$$

$$\left[ A_{wn} (\text{mm}^2/\text{m}^2) = \frac{A_{wt}}{(L_n \times H_n)} \times 10^6 \right]$$

where:

$A_{wn}$  = normalized web area, in.<sup>2</sup>/ft<sup>2</sup> [mm<sup>2</sup>/m<sup>2</sup>],  
 $A_{wt}$  = total minimum web area, in.<sup>2</sup> [mm<sup>2</sup>] (see A1.2.5),  
 $L_n$  = nominal length of unit, in. [mm], and  
 $H_n$  = nominal height of unit, in. [mm].

NOTE A1.5—Minimum web area does not apply to the portion of the unit to be filled with grout. The portion of the unit to be filled with grout should be deducted from the calculation of the normalized web area.

A1.5.3 *Equivalent Thickness*—Equivalent thickness for concrete masonry is defined as the average thickness of solid material in the unit and is calculated as follows:

$$T_e, \text{ in.} = (V_n / (L \times H)) \times 1728 \quad (\text{A1.2})$$

$$[T_e, \text{ mm} = (V_n / (L \times H))]$$

where:

$T_e$  = equivalent thickness, in. [mm],  
 $V_n$  = average net volume of full-size units, ft<sup>3</sup> [mm<sup>3</sup>] (see 9.5),  
 $L$  = average length of full-size units, in. [mm] (see A1.2.1), and  
 $H$  = average height of full-size units, in. [mm] (see A1.2.1).

A1.5.3.1 Equivalent thickness shall only be calculated and reported for full-size concrete masonry units.

A1.5.4 *Percent Solid*—Calculate the percent solid as follows:

Inch-pound units:

$$\text{Percent solid, (\%)} = \left( \frac{V_n \times 1728}{(L \times W \times H)} \right) \times 100 \quad (\text{A1.3})$$

SI units:

$$\left[ \text{Percent solid, (\%)} = \left( \frac{V_n \times 1000}{(L \times W \times H)} \right) \times 100 \right] \quad (\text{A1.4})$$

where:

$V_n$  = net volume of specimen, ft<sup>3</sup> [cm<sup>3</sup>] (see 9.5),  
 $L$  = average length of specimen, in. [mm] (see A1.2.1),  
 $W$  = average width of specimen, in. [mm] (see A1.2.1), and  
 $H$  = average height of specimen, in. [mm] (see A1.2.1).

NOTE A1.6—This calculation determines the percentage of concrete in the gross volume of the unit. It is a useful reference value, but it is not a requirement