



Standard Specification for Packing Material, Graphitic or Carbon Braided Yarn¹

This standard is issued under the fixed designation F2191/F2191M; the number immediately following the designation indicates the year of original adoption or, in the case of revision, the year of last revision. A number in parentheses indicates the year of last reapproval. A superscript epsilon (ϵ) indicates an editorial change since the last revision or reapproval.

^{e1} NOTE—Keywords were added editorially in February 2020.

1. Scope

1.1 This specification covers staple or continuous filament carbon/graphite yarn valve stem compression packing, suitable for use as end-rings on packing systems for valves. Intended services include steam, hydrocarbons, water, and non-oxidizing chemicals. Where this specification is invoked as ASTM F2191/F2191M, Sections 1 – 18 apply. Where this specification is invoked as ASTM/DoD F2191/F2191M, Sections 1 – 18 and the Supplementary Requirements shall be applicable.

1.2 The values stated in either SI units or inch-pound units are to be regarded separately as standard. The values stated in each system are not necessarily exact equivalents; therefore, to ensure conformance with the standard, each system shall be used independently of the other, and values from the two systems shall not be combined.

1.3 *This standard does not purport to address all of the safety concerns, if any, associated with its use. It is the responsibility of the user of this standard to establish appropriate safety, health, and environmental practices and determine the applicability of regulatory limitations prior to use.*

1.4 *This international standard was developed in accordance with internationally recognized principles on standardization established in the Decision on Principles for the Development of International Standards, Guides and Recommendations issued by the World Trade Organization Technical Barriers to Trade (TBT) Committee.*

2. Referenced Documents

2.1 ASTM Standards:²

¹ This specification is under the jurisdiction of ASTM Committee F25 on Ships and Marine Technology and is the direct responsibility of Subcommittee F25.02 on Insulation/Processes.

Current edition approved Feb. 1, 2020. Published March 2020. Originally approved in 2002. Last previous edition approved in 2013 as F2191/F2191M – 13. DOI: 10.1520/F2191_F2191M-13R20E01.

² For referenced ASTM standards, visit the ASTM website, www.astm.org, or contact ASTM Customer Service at service@astm.org. For *Annual Book of ASTM Standards* volume information, refer to the standard's Document Summary page on the ASTM website.

C135 Test Method for True Specific Gravity of Refractory Materials by Water Immersion

C561 Test Method for Ash in a Graphite Sample

C562 Test Method for Moisture in a Graphite Sample

C816 Test Method for Sulfur Content in Graphite by Combustion-Iodometric Titration Method

C889 Test Methods for Chemical and Mass Spectrometric Analysis of Nuclear-Grade Gadolinium Oxide (Gd₂O₃) Powder

D129 Test Method for Sulfur in Petroleum Products (General High Pressure Decomposition Device Method)

D512 Test Methods for Chloride Ion in Water

D1179 Test Methods for Fluoride Ion in Water

D1246 Test Method for Bromide Ion in Water

D3178 Test Methods for Carbon and Hydrogen in the Analysis Sample of Coal and Coke (Withdrawn 2007)³

D3684 Test Method for Total Mercury in Coal by the Oxygen Bomb Combustion/Atomic Absorption Method (Withdrawn 2014)³

D3761 Test Method for Total Fluorine in Coal by the Oxygen Bomb Combustion/Ion Selective Electrode Method (Withdrawn 2019)³

D3951 Practice for Commercial Packaging

D4239 Test Method for Sulfur in the Analysis Sample of Coal and Coke Using High-Temperature Tube Furnace Combustion

2.2 Military Standards:⁴

MIL-STD-129 Marking for Shipment and Storage

MIL-P-24583 Packing Material, Graphitic or Carbon Braided Yarn

MIL-P-24503 Packing Material, Graphitic, Corrugated Ribbon or Textured Tape and Preformed Ring

2.3 Fluid Sealing Association Handbook:⁵

Guidelines for the Use of Compression Packings, Copyright 1997

³ The last approved version of this historical standard is referenced on www.astm.org.

⁴ Available from DLA Document Services, Building 4/D, 700 Robbins Ave., Philadelphia, PA 19111-5094, <http://quicksearch.dla.mil>.

⁵ Available from the Fluid Sealing Association, 994 Old Eagle School Road, Suite 1019, Wayne, PA 19087-1866, <http://www.fluidsealing.com>

3. Terminology

3.1 Definitions:

3.1.1 *base fiber density, n*—bulk density of the base fiber before being coated or impregnated and braided into packing.

3.1.2 *braided flexible graphite, n*—a braid constructed of continuous strands or strips of expanded flexible graphite tape or ribbons, which have been overwrapped or have imbedded reinforcing fibers.

3.1.3 *carbon fibers, n*—fibers used in braided packing are produced from viscose rayon, pitch, or polyacrylonitrile (PAN) and are defined as a yarn with a carbon assay of less than 99 %.

3.1.4 *carbon yarns, n*—manufactured from continuous or staple carbon fibers that are twisted or plied into continuous individual strands of between 6 and 18 μm in diameter.

3.1.5 *carbon/graphite fibers, n*—carbon/graphite fibers used in braided packing are produced from viscose rayon, pitch, or polyacrylonitrile (PAN).

3.1.6 *center or corner filler strands, n*—strands of fiber/yarn that run parallel to the longitudinal axis of the braid in the corners or center to control the internal density and dimensional stability of the braid.

3.1.7 *continuous, adj*—individual fibers are almost infinite in length.

3.1.8 *continuous or staple carbon/graphite, n*—continuous or staple defines the length of the individual fibers in the carbonaceous yarn. Continuous means the fibers are infinite in length and staple means the individual fibers are at least 75 mm [3 in.] long and preferably 150 to 200 mm [6 to 8 in.] long. All of the fibers are between 6 to 18 μm in diameter and are twisted/plied into continuous strands called yarns.

3.1.9 *corrosion inhibitors, n*—additives to the yarn or braid to function in a passive or sacrificial manner to reduce galvanic corrosion such as embedded zinc powder, phosphorus, or barium molybdate.

3.1.10 *detrimental materials, n*—abrasive or chemically active constituents such as abrasive ash particles (in high ash content foils) or elemental materials as in **Table 2**.

3.1.11 *diagonal interlocking braid, n*—these strands criss-cross from the surface of the braid diagonally through the body of the braid and each strand is strongly locked by other strands to form an integral structure (see **Fig. 1**).

TABLE 1 Chemical and Physical Properties

Property	Value	Test
Carbon Assay		
Graphitic	99 % by mass, min.	13.4
Carbon	95 % by mass, min.	13.4
Ash	1 % by mass, max.	13.5
Finished Packing (in as-supplied state):		
Specific gravity	1.38 g/cc, min.	13.6
Moisture content	3 %, max.	13.7
Compression recovery	25 %, min.	13.10

TABLE 2 Detrimental Materials (Class 2 Only (See 13.8))

Element	Maximum Allowable Total Impurity Levels in parts per million (ppm)
Mercury (Hg)	10
Sulfur (S)	750
Total halogens (chlorine, bromine, and fluorine)	500
Chlorine (Cl)	250
Bromine (Br)	250
Fluorine (F)	250

3.1.12 *dispersion, n*—various coatings or impregnants added to the base fibers or braid to facilitate handling, lubricate the fibers, accelerate break-in, or act as blocking agents during use.

3.1.13 *graphite fibers, n*—fibers used in braided packing are produced from viscose rayon, pitch, or polyacrylonitrile (PAN) and are defined as a yarn with a carbon assay of 99 % or higher.

3.1.14 *graphite yarns, n*—manufactured from continuous or staple graphite fibers that are twisted or plied into continuous individual strands between 6 to 18 μm in diameter.

3.1.15 *lot, n*—all finished packing of one size, type, class, and grade produced in a continuous run or at the same time and under essentially the same conditions.

3.1.16 *PAN*—polyacrylonitrile fibers used as precursors to manufacture carbon/graphite for braided packing.

3.1.17 *PTFE*—polytetrafluoroethylene. (**Warning**—Graphitic valve packing containing PTFE has been associated with accelerated valve stem corrosion.)

3.1.18 *specific gravity, n*—the ratio of the mass of a unit volume of a material at a stated temperature to the mass of the same volume of distilled water at the same temperature.

3.1.19 *square plait braid, n*—the strands in this type of braid interlock in a single plane and do not interlock through the body of the braid (see **Fig. 1**).

3.1.20 *staple carbon/graphite, n*—individual fibers are at least 75 mm [3 in.] long and preferably 150 to 200 mm [6 to 8 in.] long.

3.1.21 *unraveling, v*—a loss of the original braiding shape or dimensions of the cut end extending from the cut for a distance greater than that specified along the axis of the packing.

4. Classification

4.1 *Classification*—The material shall be of the following types, classes, and grades, as specified (see 5.1):

4.1.1 *Type I*—Continuous carbon or graphite yarn.

4.1.2 *Type II*—Staple carbon or graphite yarn.

4.1.3 *Type III*—Braided flexible graphite.

4.1.3.1 *Class 1*—For use where detrimental material and lubricant content of the packing need not be controlled beyond normal manufacturing limits.

4.1.3.2 *Class 2*—For use where detrimental materials content must be controlled to limits specified herein.

4.1.3.3 *Class 3*—For use where detrimental materials content need not be controlled beyond normal manufacturing limits, and media temperatures do not exceed 500°F [260°C].

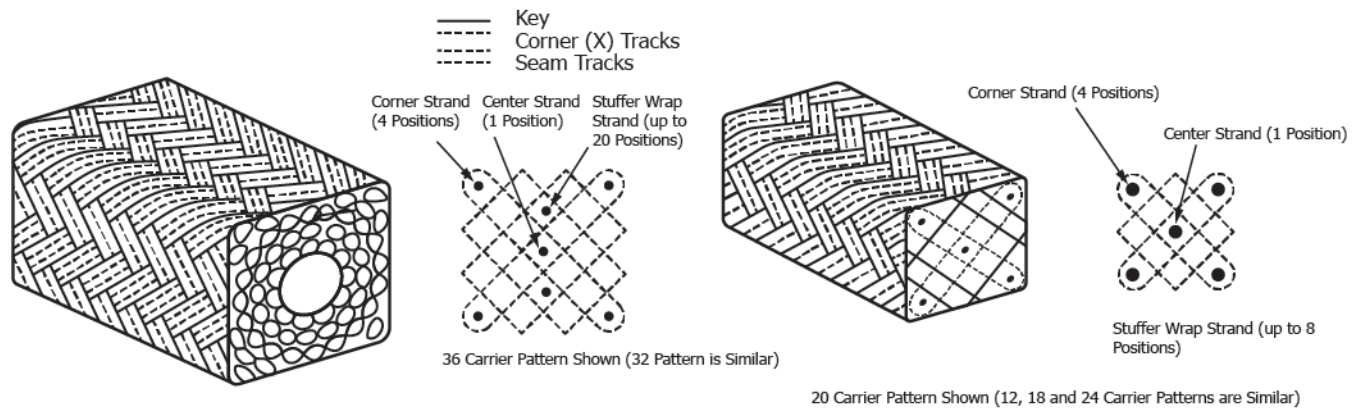

Diagonal Interlocking Through-Body-to-Surface Construction (Sizes 6 mm [¼ in.] and Over)

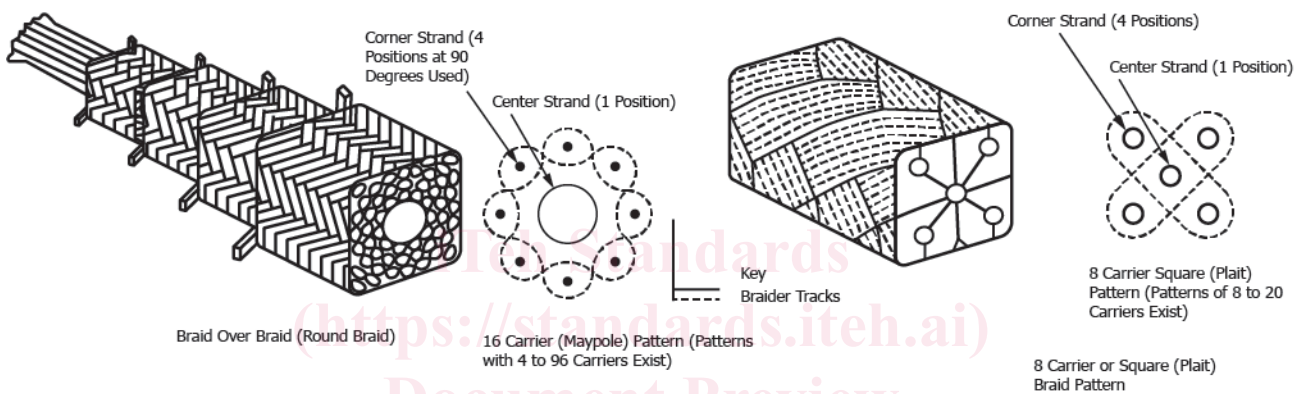

Interlocking and Square Plait Versus Braid-Over-Braid Patterns

FIG. 1 Packing Construction

- (1) *Grade A*—Treated with corrosion inhibitor.
- (2) *Grade B*—No corrosion inhibitor.

5.1.11 Marking requirements (see 17.1 and Supplementary Requirements).

5. Ordering Information

5.1 Acquisition Requirements—Acquisition documents must specify the following:

- 5.1.1 Title, number, and date of this specification.
- 5.1.2 Type, Class, and Grade required (see Section 4).
- 5.1.3 Carbon or graphite.
- 5.1.4 Type of corrosion inhibitor.
- 5.1.5 Chemical properties (see 7.1).
- 5.1.6 Inspection, testing, and certification of the material shall be agreed upon between the purchaser and the supplier as part of the purchase contract.
- 5.1.7 Size required (see 9.1). When pre-cut rings are desired, specify the braid cross-section, inside diameter, outside diameter, and number of rings required.
- 5.1.8 Put-up, if other than required by Table S4.1 (see Supplementary Requirements).
- 5.1.9 Application data.
- 5.1.10 Packaging requirements (see Section 18 and Supplementary Requirements).

6. Materials and Manufacture

6.1 Materials and Manufacture—The material shall be as specified in 6.1.1 – 6.1.5.

- 6.1.1 Yarn:
 - 6.1.1.1 Type I packing shall be made of continuous filament carbon or graphite yarn.
 - 6.1.1.2 Type II shall be made of staple carbon or graphite yarn.
 - 6.1.1.3 Type III shall be made of flexible graphite.
- 6.1.2 Packing:
 - 6.1.2.1 Class 1 packing shall be made of Type I or Type II yarn and shall have a pure graphitic dispersion or carbon dispersion.
 - 6.1.2.2 Class 2 packing shall be made of Type I yarn and shall have a pure graphite or carbon dispersion.
 - 6.1.2.3 Class 3 packing shall be made of Type I or Type II yarn and shall have a pure graphite, or carbon dispersion and are permitted to be coated with polytetrafluoroethylene (PTFE) (see 7.2 and 13.9).

6.1.3 Coating and Corrosion Inhibiting Treatments:

6.1.3.1 *Grade A*—Grade A packing shall be provided with a powdered zinc (Zn) active corrosion inhibiting treatment or a passive inhibiting treatment such as phosphorus or barium molybdate. If required, both active and passive inhibitors shall be used.

6.1.3.2 *Grade B*—Grade B packing shall not contain corrosion inhibiting additives.

6.1.4 *Packing Construction (Type I and Type II)*—Packing shall be square (plait) braided for cross-sectional sizes smaller than 6 mm [$\frac{1}{4}$ in.]. Cross-sectional sizes of 6 mm [$\frac{1}{4}$ in.] or greater shall use a diagonal interlocking type construction. The diagonal interlocking constructions shall consist of either single or plied yarns braided on 12, 18, 20, 24, 32, or 36 carrier braiding machines. Additional axial center, corner, and (stuffer) warp yarn(s) can be added within the braid as necessary to produce a dense square cross-section packing profile with good dimensional stability.

6.1.5 *Mercury Exclusion*—During manufacturing, fabrication, handling, packaging, and packing, the packing material shall not come in contact with mercury or mercury containing compounds.

7. Properties

7.1 *Chemical and Physical Properties*—Unless otherwise specified, the properties of the finished packing shall conform to the requirements of **Table 1**. Class 2 also requires compliance with **Table 2**.

7.2 *PTFE Coating (Class 3 only)*—If PTFE is used, it shall not exceed 10 % by mass of the packing (see **13.9**) unless otherwise agreed to by the purchaser. (**Warning**—Graphitic valve packing containing PTFE has been associated with accelerated valve stem corrosion.)

7.3 *Prohibited Additions*—There shall be no intentional additions of any of the detrimental materials listed in **Table 2** or any antimony (Sb), arsenic (As), bismuth (Bi), cadmium (Cd), gallium (Ga), indium (In), lead (Pb), mercury (Hg), silver (Ag), or tin (Sn), or, in the case of Grade B packing, zinc (Zn).

8. Other Requirements

8.1 *Braid Geometry Retention*—Untaped, cut ends shall not unravel more than 3 mm [$\frac{1}{8}$ in.] with the packing dry or wet (see **13.11**). For example, packing 12 mm [$\frac{1}{2}$ -in.] in cross section shall not unravel more than 3 mm [$\frac{1}{8}$ in.] at either end of the packing.

9. Dimensions, Mass, and Permissible Variations

9.1 *Sizes and Mass*—Packing shall be furnished in the sizes shown in **Table 3**, or other size(s) as is ordered by the customer, (see Section **5** and **6.1.4**). Packing shall be formed approxi-

mately square or rectangular in cross-section (either when straight or when placed about a shaft) within the dimensional tolerances of **Table 3**. When specified in the purchase document (see **5.1** and **13.2**), the mass per linear foot (or other measure) shall be in accordance with the sizes listed in **Table 4**. Sizes not listed in **Table 4** shall be as agreed between purchaser and manufacturer and specified in Section **5**, Ordering Information. Include minimum mass per linear foot as a part of the bid and purchase documents.

9.1.1 *Tolerance and Measurement Standards*—The generally accepted method of measurements in the packing manufacturing environment is a hand held, direct reading, vernier caliper. To ensure concentricity, the inside diameter is measured using a ground dimensional plug gauge and the outside diameter is measured by the above (caliper) while the plug is inserted. Information regarding tolerance and measurement is available in the Guidelines for the Use of Compression Packings published by the FSA.

10. Workmanship, Finish, and Appearance

10.1 *Workmanship*—The packing shall be free of defects that have the potential to affect its serviceability as defined in **Table 5**.

10.2 *Construction*—The sample shall be visually examined and confirmed to be of the correct braid construction (square plait braid or diagonal interlocking braid) for the ordered size (see **5.1** and **6.1.4**).

11. Quality Assurance

11.1 *Quality Systems*—Manufacturers shall be prepared to document use of a quality system such as compliance with an ISO 9000 series program or similar program.

12. Specimen Preparation

12.1 *Specimen Preparation*—Buyer and seller shall agree on specimen preparation.

13. Test Methods

13.1 *Tests*—In the event that testing is required as part of the purchasing requirements **5.1**, tests shall be made in accordance with the following or by way of alternate methods of analysis with equal to or improved accuracy and precision. The use of an alternate analytical method requires the prior written consent of the purchasing party before acceptance will be allowed.

13.2 *Size*—Before unbraiding, the size shall be determined by measuring each sample selected for visual examination (see **Table 3**). A steel rule with 1 mm [$\frac{1}{32}$ in.] divisions accurate to 1 mm [$\frac{1}{32}$ in.] or a steel slide caliper with 1 mm [$\frac{1}{32}$ in.] and 0.5 mm [$\frac{1}{64}$ in.] divisions shall be used (see **9.1**).

13.3 *Mass*—The mass shall be determined using a specimen at least 609.6 mm [2 ft] in length for measurement in conjunction with the values of **Table 4**.

13.4 *Carbon Assay*—The sample shall be dried to a constant mass at $149 \pm 3^\circ\text{C}$ [$300 \pm 5^\circ\text{F}$] before testing. For Grade A packing only, the test shall be conducted prior to the corrosion inhibiting treatment or the added mass of the corrosion inhibitor shall be determined and subtracted from the base

TABLE 3 Manufacturing Tolerances by Cross-Sectional Size

Cross Section SI	Cross Section IP	Tolerance SI	Tolerance IP
Up to 6 mm	Up to $\frac{1}{4}$ in.	± 0.4 mm	$\pm \frac{1}{64}$ in.
6 to 25 mm, incl	$\frac{1}{4}$ to 1 in., incl	± 0.8 mm	$\pm \frac{1}{32}$ in.
greater than 25 mm	greater than 1 in.	± 1.6 mm	$\pm \frac{1}{16}$ in.