



Designation: D7100 – 11 (Reapproved 2020)

Standard Test Method for Hydraulic Conductivity Compatibility Testing of Soils with Aqueous Solutions¹

This standard is issued under the fixed designation D7100; the number immediately following the designation indicates the year of original adoption or, in the case of revision, the year of last revision. A number in parentheses indicates the year of last reapproval. A superscript epsilon (ϵ) indicates an editorial change since the last revision or reapproval.

1. Scope

1.1 This test method covers hydraulic conductivity compatibility testing of saturated soils in the laboratory with aqueous solutions that may alter hydraulic conductivity (for example, waste related liquids) using a flexible-wall permeameter. A hydraulic conductivity test is conducted until both hydraulic and chemical equilibrium are achieved such that potential interactions between the soil specimen being permeated and the aqueous solution are taken into consideration with respect to the measured hydraulic conductivity.

1.2 This test method is applicable to soils with hydraulic conductivities less than approximately 1×10^{-8} m/s.

1.3 In addition to hydraulic conductivity, intrinsic permeability can be determined for a soil if the density and viscosity of the aqueous solution are known or can be determined.

1.4 This test method can be used for all specimen types, including undisturbed, reconstituted, remolded, compacted, etc. specimens.

1.5 A specimen may be saturated and permeated using three methods. Method 1 is for saturation with water and permeation with aqueous solution. Method 2 is for saturation and permeation with aqueous solution. Method 3 is for saturation with water, initial permeation with water, and subsequent permeation with aqueous solution.

1.6 The amount of flow through a specimen in response to a hydraulic gradient generated across the specimen is measured with respect to time. The amount and properties of influent and effluent liquids are monitored during the test.

1.7 The hydraulic conductivity with an aqueous solution is determined using procedures similar to determination of hydraulic conductivity of saturated soils with water as described in Test Methods **D5084**. Several test procedures can be used, including the falling headwater-rising tailwater, the constant-

head, the falling headwater-constant tailwater, or the constant rate-of-flow test procedures.

1.8 *Units*—The values stated in SI units are to be regarded as standard. The values given in parentheses are provided for information only and are not considered standard.

1.8.1 Hydraulic conductivity has traditionally been expressed in cm/s in the U.S., even though the official SI unit for hydraulic conductivity is m/s.

1.8.2 The gravitational system of inch-pound units is used when dealing with inch-pound units. In this system, the pound (lbf) represents a unit of force (weight), while the unit for mass is slugs.

1.8.3 The slug unit of mass is almost never used in commercial practice; i.e., density, balances, etc. Therefore, the standard unit for mass in this standard is either kilogram (kg) or gram (g), or both. Also, the equivalent inch-pound unit (slug) is not given/presented in parentheses. However, the use of balances or scales recording pounds of mass (lbm) or recording density in lbm/ft³ shall not be regarded as nonconformance with this standard.

1.9 This standard contains a Hazards section related to using hazardous liquids (Section 7).

1.10 *This standard does not purport to address all of the safety concerns, if any, associated with its use. It is the responsibility of the user of this standard to establish appropriate safety, health, and environmental practices and determine the applicability of regulatory limitations prior to use.*

1.11 *This international standard was developed in accordance with internationally recognized principles on standardization established in the Decision on Principles for the Development of International Standards, Guides and Recommendations issued by the World Trade Organization Technical Barriers to Trade (TBT) Committee.*

2. Referenced Documents

2.1 ASTM Standards:²

¹ This test method is under the jurisdiction of ASTM Committee **D18** on Soil and Rock and is the direct responsibility of Subcommittee **D18.04** on Hydrologic Properties and Hydraulic Barriers.

Current edition approved Feb. 15, 2020. Published March 2020. Originally approved in 2004. Last previous edition approved in 2011 as D7100–11. DOI: 10.1520/D7100-11R20.

² For referenced ASTM standards, visit the ASTM website, www.astm.org, or contact ASTM Customer Service at service@astm.org. For *Annual Book of ASTM Standards* volume information, refer to the standard's Document Summary page on the ASTM website.

- D653 Terminology Relating to Soil, Rock, and Contained Fluids
- D698 Test Methods for Laboratory Compaction Characteristics of Soil Using Standard Effort (12,400 ft-lbf/ft³ (600 kN-m/m³))
- D854 Test Methods for Specific Gravity of Soil Solids by Water Pycnometer
- D888 Test Methods for Dissolved Oxygen in Water
- D1125 Test Methods for Electrical Conductivity and Resistivity of Water
- D1293 Test Methods for pH of Water
- D1429 Test Methods for Specific Gravity of Water and Brine
- D1498 Test Method for Oxidation-Reduction Potential of Water
- D1557 Test Methods for Laboratory Compaction Characteristics of Soil Using Modified Effort (56,000 ft-lbf/ft³ (2,700 kN-m/m³))
- D1587 Practice for Thin-Walled Tube Sampling of Fine-Grained Soils for Geotechnical Purposes
- D1889 Test Method for Turbidity of Water (Withdrawn 2007)³
- D2216 Test Methods for Laboratory Determination of Water (Moisture) Content of Soil and Rock by Mass
- D2435 Test Methods for One-Dimensional Consolidation Properties of Soils Using Incremental Loading
- D3550 Practice for Thick Wall, Ring-Lined, Split Barrel, Drive Sampling of Soils
- D3740 Practice for Minimum Requirements for Agencies Engaged in Testing and/or Inspection of Soil and Rock as Used in Engineering Design and Construction
- D3977 Test Methods for Determining Sediment Concentration in Water Samples
- D4128 Guide for Identification and Quantitation of Organic Compounds in Water by Combined Gas Chromatography and Electron Impact Mass Spectrometry
- D4220 Practices for Preserving and Transporting Soil Samples
- D4327 Test Method for Anions in Water by Suppressed Ion Chromatography
- D4448 Guide for Sampling Ground-Water Monitoring Wells
- D4691 Practice for Measuring Elements in Water by Flame Atomic Absorption Spectrophotometry
- D4696 Guide for Pore-Liquid Sampling from the Vadose Zone
- D4700 Guide for Soil Sampling from the Vadose Zone
- D4753 Guide for Evaluating, Selecting, and Specifying Balances and Standard Masses for Use in Soil, Rock, and Construction Materials Testing
- D4767 Test Method for Consolidated Undrained Triaxial Compression Test for Cohesive Soils
- D4972 Test Methods for pH of Soils
- D5084 Test Methods for Measurement of Hydraulic Conductivity of Saturated Porous Materials Using a Flexible Wall Permeameter
- D5673 Test Method for Elements in Water by Inductively Coupled Plasma—Mass Spectrometry
- D5790 Test Method for Measurement of Purgeable Organic Compounds in Water by Capillary Column Gas Chromatography/Mass Spectrometry
- D6001 Guide for Direct-Push Groundwater Sampling for Environmental Site Characterization
- D6026 Practice for Using Significant Digits in Geotechnical Data
- D6151 Practice for Using Hollow-Stem Augers for Geotechnical Exploration and Soil Sampling
- D6286 Guide for Selection of Drilling and Direct Push Methods for Geotechnical and Environmental Subsurface Site Characterization
- D6517 Guide for Field Preservation of Ground Water Samples
- D6519 Practice for Sampling of Soil Using the Hydraulically Operated Stationary Piston Sampler
- D6919 Test Method for Determination of Dissolved Alkali and Alkaline Earth Cations and Ammonium in Water and Wastewater by Ion Chromatography
- E70 Test Method for pH of Aqueous Solutions With the Glass Electrode
- E691 Practice for Conducting an Interlaboratory Study to Determine the Precision of a Test Method

3. Terminology

3.1 Definitions:

3.1.1 *hydraulic conductivity*, k —(also referred to as coefficient of permeability or permeability) the rate of discharge of a permeant liquid under laminar flow conditions through a unit cross-sectional area of porous medium under a unit hydraulic gradient and at standard temperature (20°C).

3.1.2 *permeameter*—the apparatus (cell) containing the test specimen in a hydraulic conductivity test.

3.1.2.1 *Discussion*—The apparatus for this test standard is a flexible-wall cell that includes top and bottom specimen caps, including porous stones and filter paper, a flexible membrane, an annulus chamber containing water, top and bottom plates, valves, and fittings.

3.1.3 *head loss*, h —the change in total head of liquid across a given distance.

3.1.3.1 *Discussion*—The change in total head typically is measured using heads acting at influent and effluent ends of a specimen, and the given distance typically is the length of the test specimen.

3.1.4 *pore volume of flow*—the cumulative quantity of flow through a test specimen divided by the total volume of voids in the specimen.

3.1.4.1 *Discussion*—The volume of voids in a specimen that is effective in conducting flow may be lower than the total volume of voids. The voids that conduct flow are represented by an *effective porosity*. The effective porosity is lower than the total porosity. This difference affects the accuracy for determining the actual pore volumes of flow associated with a test. However, the presence and magnitude of effective porosity in a soil specimen is usually not known *a priori*. Therefore, for

³ The last approved version of this historical standard is referenced on www.astm.org.

the purposes of this standard, the determination of the pore volumes of flow will be based on the total porosity of the specimen.

3.1.5 *back pressure*—a pressure applied to the specimen pore liquid to force any air present in the specimen to compress and to therefore pass into the pore liquid resulting in an increase of the degree of saturation of the specimen.

3.2 Refer to Terminology **D653** for definitions of other terms in this standard.

4. Significance and Use

4.1 This test method is used to measure one-dimensional flow of aqueous solutions (for example, landfill leachates, liquid wastes and byproducts, single and mixed chemicals, etc., from hereon referred to as the permeant liquid) through initially saturated soils under an applied hydraulic gradient and effective stress. Interactions between some permeant liquids and some clayey soils have resulted in significant increases in the hydraulic conductivity of the soils relative to the hydraulic conductivity of the same soils permeated with water **(1)**.⁴ This test method is used to evaluate the presence and effect of potential interactions between the soil specimen being permeated and the permeant liquid on the hydraulic conductivity of the soil specimen. Test programs may include comparisons between the hydraulic conductivity of soils permeated with water relative to the hydraulic conductivity of the same soils permeated with aqueous solutions to determine variations in the hydraulic conductivity of the soils due to the aqueous solutions.

4.2 Flexible-wall hydraulic conductivity testing is used to determine flow characteristics of aqueous solutions through soils. Hydraulic conductivity testing using flexible-wall cells is usually preferred over rigid-wall cells for testing with aqueous solutions due to the potential for sidewall leakage problems with rigid-wall cells. Excessive sidewall leakage may occur, for example, when a test soil shrinks during permeation with the permeant liquid due to interactions between the soil and the permeant liquid in a rigid-wall cell. In addition, the use of a rigid-wall cell does not allow for control of the effective stresses that exist in the test specimen.

4.3 Darcy's law describes laminar flow through a test soil. Laminar flow conditions and, therefore, Darcy's law may not be valid under certain test conditions. For example, interactions between a permeating liquid and a soil may cause severe channeling/cracking of the soil such that laminar flow is not maintained through a test specimen containing large open pathways for flow.

4.4 Interactions that may clog the pore spaces of test soils (for example, precipitation) may occur during permeation with some permeant liquids. Flow through test soils may be severely restricted in these cases. In cases where the measured hydraulic conductivity is less than 1×10^{-12} m/s, unsteady state analysis may be used to determine the hydraulic conductivity of test soils **(2)**.

⁴ The boldface numbers in parentheses refer to the list of references at the end of this standard.

4.5 Specimens of initially water-saturated soils (for example, undisturbed natural soils) may be permeated with the permeant liquid. Specimens of water unsaturated soils (for example, compacted soils) may be fully saturated with water or the permeant liquid and then permeated with the permeant liquid. Specimens of soils initially partly or fully saturated with a particular liquid (for example, specimens collected from a containment facility subsequent to a period of use) may be fully saturated and then permeated with the same or another liquid. The use of different saturating and permeating liquids can have significant effects both on the results and the interpretation of the results of a test **(1)**. Selection of type and sequence of liquids for saturation and permeation of test specimens is based on the characteristics of the test specimens and the requirements of the specific application for which the hydraulic conductivity testing is being conducted in a test program. The user of this standard is responsible for selecting and specifying the saturation and permeation conditions that best represent the intended application.

4.6 Hydraulic conductivity of a soil with water and aqueous solution can be determined using two approaches in a test program for comparisons between the hydraulic conductivity based on permeation with water and the hydraulic conductivity based on permeation with aqueous solution. In the first approach, specimens are initially saturated (if needed) and permeated with water and then the permeating liquid is switched to the aqueous solution. This testing sequence allows for determination of both water and aqueous solution hydraulic conductivities on the same specimen. Obtaining water and aqueous solution values on the same specimen reduces the uncertainties associated with specimen preparation, handling, and variations in test conditions. However, such testing sequences may not represent actual field conditions and may affect the results of a test. In the second approach, two specimens of the same soil are permeated, with one specimen being permeated with water and the other specimen being permeated with the aqueous solution. The specimens are prepared using the same sample preparation and handling methods and tested under the same testing conditions. This approach may represent actual field conditions better than the first approach, however, uncertainties may arise due to the use of separate specimens for determining hydraulic conductivities based on permeation with water and the aqueous solution. Guidelines for preparing and testing multiple specimens for comparative studies are provided in Practice **E691**. The user of this standard shall be responsible for selecting and specifying the approach that best represents the intended application when comparisons of hydraulic conductivity are required.

4.7 Termination criteria used in the test method are based on both achieving steady-state conditions with respect to flow and equilibrium between the chemical composition of the effluent (outflow) relative to the influent (inflow).

4.8 Intrinsic permeability can be determined in addition to hydraulic conductivity using results of permeation tests described in this standard.

4.9 The correlation between results obtained using this test method and the hydraulic conductivities of in-place field

materials has not been completely determined. Differences may exist between the hydraulic conductivities measured on small test specimens in the laboratory and those obtained for larger volumes in the field. Therefore, the results obtained using this standard should be applied to field situations with caution and by qualified personnel.

4.10 While not required for determining the hydraulic conductivity of soils with aqueous solutions, soil chemical properties such as pH, electrical conductivity, exchangeable metals (cations), and cation exchange capacity as well as the mineralogical composition of the soil may be useful in the interpretation and explanation of the test results.

NOTE 1—The quality of the result produced by this standard is dependent of the competence of the personnel using this standard and the suitability of the equipment and facilities. Agencies that meet the criteria of Practice D3740 are generally considered capable of competent and objective testing/sampling/inspection/etc. Users of this standard are cautioned that compliance with Practice D3740 does not in itself assure reliable results. Reliable results depend on many factors; Practice D3740 provides a means of evaluating some of these factors.

5. Apparatus

5.1 Schematics of the various components of a measurement system are provided in Fig. 1 (permeant interface device) and Fig. 2 (testing apparatus including hydraulic system, flow-measurement system, and permeameter). Compatibility of all of the testing components that come into contact with the

permeant liquid shall be determined prior to testing. This determination applies not only to the testing apparatus and peripheral equipment used to measure the hydraulic conductivity, but also to the auxiliary equipment and apparatus used for determining both the chemical properties of the permeant liquid (density, pH, etc.) and the physical properties of the test specimens (dimensions, moisture content, etc.). Determination of compatibility is particularly critical if aqueous solutions that contain more than 50 % of miscible organic liquids are used in a test program.

5.2 *Permeant Interface Device (Bladder Accumulator)* —A schematic of a permeant interface device, also referred to as a bladder accumulator, is presented in Fig. 1 (see Refs 1 and 3 for additional detail). The device is divided into two chambers. One chamber contains water and is connected to hydraulic and flow-measurement systems. The other chamber contains the permeant liquid and is connected to permeameter cell and thus the specimen. The chambers are separated by a chemically resistant flexible bladder. Pressure applied to the water is fully transferred to the accompanying permeant liquid in the adjacent chamber through the membrane. Drainage lines and/or sampling ports are included in the design of permeant interface devices for rapid filling or drainage and also for sampling of the permeant liquid during permeation. The permeant interface device shall prevent release of the permeant liquid to the

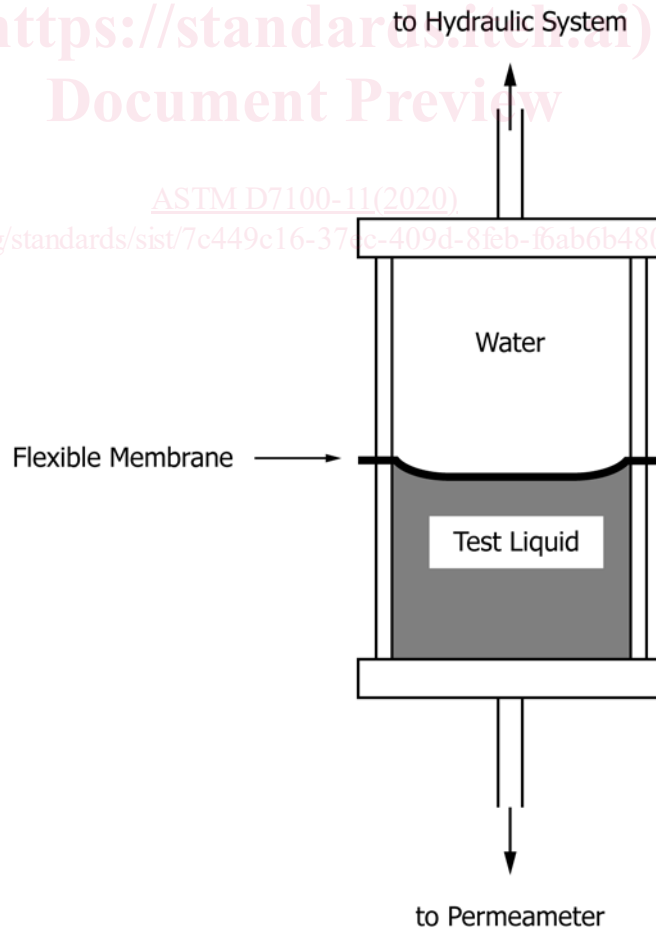

FIG. 1 Permeant Interface Device (Bladder Accumulator) [see Refs 1 and 3 for additional detail]

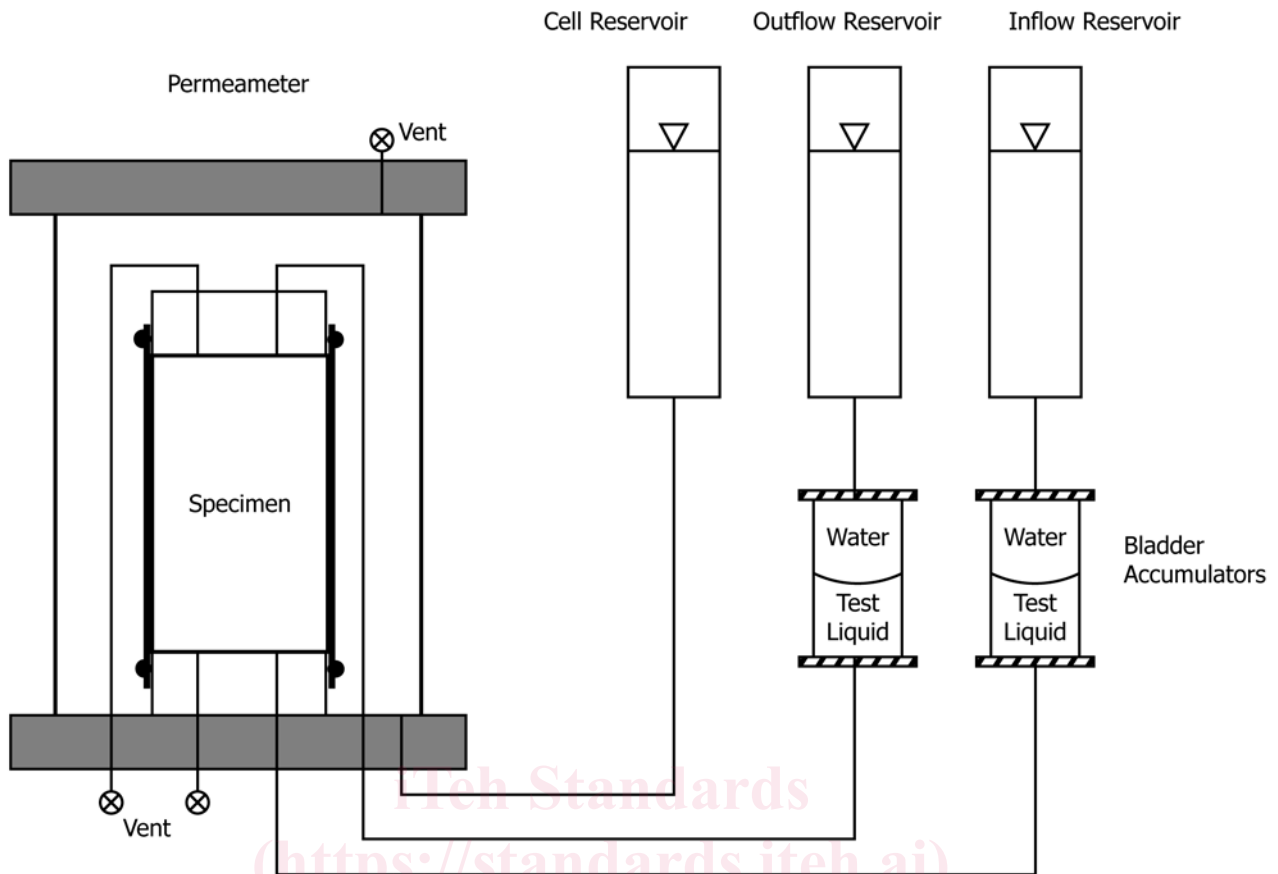

FIG. 2 Example of Test Setup

surrounding environment and also shall prevent contact of the permeant liquid with the hydraulic system and the flow-measurement system. Permeant interface devices shall be used when the test liquid is hazardous or volatile. Permeant interface devices may also be used for non-hazardous permeant liquids. Use of bladder accumulators minimizes the need for involved clean-up procedures for the hydraulic and flow-measurement systems. When used, two bladder accumulators are required, one connected to the influent line and the other connected to the effluent line.

5.2.1 The permeant interface device shall be constructed of stainless steel of sufficient grade or other material that is resistant to the permeant liquid. All fittings shall be constructed of materials resistant to the permeant liquid. All tubing shall also be resistant to the permeant liquid. Teflon® may be used for tubing that comes in contact with the permeant liquid. The bladder shall be constructed of a flexible and chemically resistant material. Materials such as viton, nitrile, or ethylene propylene are commonly used for the bladder, but other materials that are resistant to the permeant liquid may also be used. The long-term compatibility of all components with test liquids shall be verified.

5.2.2 The bladder shall be carefully inspected prior to use. The bladder shall be discarded if any defects such as pinholes are observed. The device shall be checked for leaks at the maximum expected test pressure prior to testing by filling one

of the chambers with water and the other chamber with colored water. The device shall be connected to the permeameter cell for this verification. Any mixing of the clear water with the colored water indicates leaks through the bladder. Also, the pressure lines and fittings as well as around the bladder interface shall be inspected for any leaks.

5.3 *Hydraulic System*—The hydraulic system is used to apply, maintain, and measure heads and resulting hydraulic gradients in a test. The hydraulic system consists of reservoirs that hold water and/or the test liquid, pressure application setups that are used to pressurize influent and effluent liquids, and associated piping, tubing, valves, and connections (Fig. 2). The hydraulic conductivity can be measured using one of the following test procedures: falling headwater-rising tailwater, constant head, falling headwater-constant tailwater, or constant rate of flow. The requirements for hydraulic systems for each procedure are provided below:

5.3.1 *Falling Headwater-Rising Tailwater*—The system shall allow for measurement of the applied head, the variations in head, and the gradient to within $\pm 5\%$ or better accuracy during a test. The head shall be measured with a pressure gage, electronic pressure transducer, engineer's scale, graduated pipette, or any other device that has the resolution required for the determination of head and gradient to the accuracy provided above.

5.3.2 Constant Head—The system shall allow for maintaining constant hydraulic head to within $\pm 5\%$ or better accuracy during a test. The system shall allow for measurement of the constant head to within $\pm 5\%$ or better accuracy during a test. The head shall be measured with a pressure gage, electronic pressure transducer, engineer's scale, graduated pipette, or any other device that has the resolution required for the determination of head to the accuracy provided above.

5.3.3 Falling Headwater-Constant Tailwater—The requirements are similar to **5.3.1** for the falling headwater elevation. For the constant tailwater elevation, the system shall allow for maintaining a constant hydraulic head to within $\pm 5\%$ or better accuracy at the tailwater. The system shall also allow for the measurement of the constant head to within $\pm 5\%$ or better accuracy during a test. The requirements for measurement of the constant head are similar to **5.3.2**.

5.3.4 Constant Rate of Flow—The system shall allow for maintaining a constant rate of flow through a specimen to within $\pm 5\%$ or better accuracy. Flow shall be measured by calibrated syringe, graduated pipette, or other device that has the precision required for the determination of flow to the accuracy provided above. The head loss across the specimen shall be measured to within $\pm 5\%$ or better accuracy using an electronic pressure transducer or other device of suitable resolution.

5.3.5 System De-airing—The hydraulic system shall be designed to facilitate rapid and complete removal of free air bubbles from flow lines. This can be accomplished for example by using properly sized tubing and ball valves, and fittings without pipe threads. Properly sized components are small enough to prevent entrapment of air bubbles, but are large enough not to cause head losses as described in **5.5.4**.

5.3.6 Back-Pressure System—The hydraulic system shall be equipped to apply back pressure to the specimen to facilitate saturation. The system shall be equipped to maintain the applied back pressure throughout the duration of hydraulic conductivity measurements. The back-pressure system shall allow for applying, controlling, and measuring the back pressure to within $\pm 5\%$ or better accuracy. The back pressure may be provided by a compressed gas supply, a deadweight acting on a piston, or any other method that has the resolution required for application of back pressure to the accuracy provided above.

NOTE 2—Application of gas pressure directly to a liquid will dissolve gas in the liquid. A variety of techniques are available to minimize dissolution of gas in the back-pressure liquid, including separation of gas and liquid phases with a bladder and frequent replacement of the liquid with de-aired liquid.

5.4 Flow-Measurement System—Flow-measurement system is used to determine the amount of inflow and outflow from a specimen during a test. The measurement device shall allow for the measurement of the quantity of flow (both inflow and outflow) over an interval of time to within $\pm 5\%$ or better accuracy. Flow-measurement system consists of a graduated accumulator, graduated pipette, vertical standpipe in conjunction with an electronic pressure transducer, or other volume-measuring device that has the resolution required for the

determination of flow to the accuracy provided above (**Fig. 2**). In most cases, these devices are common to the hydraulic system.

5.4.1 De-airing and Dimensional Stability of the System—The flow-measurement system shall contain a minimum of dead space and shall be equipped to allow for complete and rapid de-airing. Dimensional stability of the system with respect to changes in pressure shall be ensured by using a stiff flow-measurement system that includes glass pipe or rigid metallic or thermoplastic tubing.

5.5 Permeameter—The permeameter shall allow for applying a controlled cell pressure around a specimen and for transmitting a permeant liquid through a specimen under applied inflow and outflow pressures. The permeameter shall consist of a permeameter cell and attached equipment that allow for connecting the permeameter to the hydraulic system and the flow-measurement system as well as provisions to support a specimen and to permeate a specimen. The permeameter cell shall consist of a cover plate, base plate, annulus chamber, and attachments to hold the components together without leakage during a test (**Fig. 2**).

5.5.1 Cell Pressure System—The system for pressurizing the permeameter cell shall allow for applying and controlling the cell pressure to within $\pm 5\%$ or better accuracy. The effective stress on the test specimen (that is the difference between the cell pressure and the pore liquid pressure) shall be maintained to the desired value with an accuracy of $\pm 10\%$ or better. The cell pressure system may consist of a reservoir connected to the permeameter cell and partially filled with de-aired water, with the upper part of the reservoir connected to a compressed gas supply or other source of pressure (see **Note 3**). The gas pressure shall be controlled by a pressure regulator and measured by a pressure gage, electronic pressure transducer, or any other device that has the resolution required to apply and control the pressure to the accuracy provided above. A hydraulic system pressurized by deadweight acting on a piston or any other pressure device that allows for applying and controlling the permeameter cell pressure within the tolerance prescribed above may also be used.

NOTE 3—De-aired water is commonly used for the cell liquid to minimize potential for diffusion of air through the membrane into the specimen. Other liquids that have low gas solubilities such as oils, are also acceptable, provided they do not react with the membrane and the components of the permeameter.

5.5.2 The specimen shall be overlain and underlain by porous end pieces and encased in a flexible membrane. Filter paper shall be placed between the porous end pieces and the specimen. A top cap and a bottom cap shall be used at the top and bottom ends of a specimen, respectively. The components shall be assembled such that the specimen and the influent and the effluent lines that are connected to these components shall be sealed against the surrounding cell liquid.

5.5.2.1 Porous End Pieces—Porous end pieces shall be used to distribute permeant liquid uniformly over the surfaces of a test specimen (that is, areas perpendicular to the direction of flow). Porous end pieces shall be constructed of silicon carbide, aluminum oxide, or other material that does not react with the specimen or the permeant liquid. The end pieces shall have