



Designation: D3575 – 20

Standard Test Methods for Flexible Cellular Materials Made from Olefin Polymers¹

This standard is issued under the fixed designation D3575; the number immediately following the designation indicates the year of original adoption or, in the case of revision, the year of last revision. A number in parentheses indicates the year of last reapproval. A superscript epsilon (ϵ) indicates an editorial change since the last revision or reapproval.

1. Scope*

1.1 These test methods apply to flexible closed cell materials made from olefin polymers or blends of olefin polymers with other polymers as defined in Section 3.

1.2 These test methods cover test procedures only. Product requirements are outlined in Specification D4819.

1.3 Unless specifically stated otherwise, by agreement between the purchaser and supplier, all tests shall be performed in accordance with the test methods specified in this standard.

1.4 The values stated in SI units are to be regarded as the standard.

1.5 *This standard does not purport to address all of the safety concerns, if any, associated with its use. It is the responsibility of the user of this standard to establish appropriate safety, health, and environmental practices and determine the applicability of regulatory limitations prior to use.*

NOTE 1—This standard and ISO 7214 address the same subject matter, but differ in technical content.

1.6 *This international standard was developed in accordance with internationally recognized principles on standardization established in the Decision on Principles for the Development of International Standards, Guides and Recommendations issued by the World Trade Organization Technical Barriers to Trade (TBT) Committee.*

2. Referenced Documents

2.1 *ASTM Standards:*²

C177 Test Method for Steady-State Heat Flux Measurements and Thermal Transmission Properties by Means of the Guarded-Hot-Plate Apparatus

C518 Test Method for Steady-State Thermal Transmission Properties by Means of the Heat Flow Meter Apparatus

¹ These test methods are under the jurisdiction of ASTM Committee D20 on Plastics and are the direct responsibility of Subcommittee D20.22 on Cellular Materials - Plastics and Elastomers.

Current edition approved Feb. 1, 2020. Published March 2020. Originally approved in 1977. Last previous edition approved in 2014 as D3575-14. DOI: 10.1520/D3575-20.

² For referenced ASTM standards, visit the ASTM website, www.astm.org, or contact ASTM Customer Service at service@astm.org. For *Annual Book of ASTM Standards* volume information, refer to the standard's Document Summary page on the ASTM website.

- D412 Test Methods for Vulcanized Rubber and Thermoplastic Elastomers—Tension
- D624 Test Method for Tear Strength of Conventional Vulcanized Rubber and Thermoplastic Elastomers
- D883 Terminology Relating to Plastics
- D1056 Specification for Flexible Cellular Materials—Sponge or Expanded Rubber
- D1349 Practice for Rubber—Standard Conditions for Testing
- D1596 Test Method for Dynamic Shock Cushioning Characteristics of Packaging Material
- D1667 Specification for Flexible Cellular Materials—Poly (Vinyl Chloride) Foam (Closed-Cell)
- D2863 Test Method for Measuring the Minimum Oxygen Concentration to Support Candle-Like Combustion of Plastics (Oxygen Index)
- D4819 Specification for Flexible Cellular Materials Made From Polyolefin Plastics
- E177 Practice for Use of the Terms Precision and Bias in ASTM Test Methods
- E456 Terminology Relating to Quality and Statistics
- E691 Practice for Conducting an Interlaboratory Study to Determine the Precision of a Test Method
- E2935 Practice for Conducting Equivalence Testing in Laboratory Applications
- F355 Test Method for Impact Attenuation of Playing Surface Systems, Other Protective Sport Systems, and Materials Used for Athletics, Recreation and Play

3. Terminology

3.1 Terms used in this standard are defined in accordance with Terminology D883, unless otherwise specified. For terms relating to precision, bias and associated issues, the terms used in this standard are defined in accordance with Terminology E456.

3.2 *Definitions of Terms Specific to This Standard:*

3.2.1 *blend, n*—mixture of olefin polymers with other monomer(s) or polymer(s) in which at least 51 mass percent is the olefin polymer.

3.2.2 *flexible cellular material, n*—a cellular polymer that will not visibly rupture within a specified time when a specimen is bent around a 25.4 mm (1.0 in.) mandrel 180

*A Summary of Changes section appears at the end of this standard

degrees within an agreed upon period of time and at a predetermined temperature.

3.2.3 *constant compression creep, n*—the time-dependent change in thickness of a material under a constant compressive stress or compression force.

3.2.4 *olefin polymers, n*—polymers made by the polymerization of olefins or copolymerization of olefins with other monomers, the olefins being at least 51 mass percent.

4. Summary of Test Methods

4.1 **Table 1** contains a list of all the assigned suffix letters that are used in describing the cellular products covered by these test methods.

4.2 These test methods do not contain test methods for all the suffix letters listed in **Table 1**. Where the test method is not included, it shall be arranged between the purchaser and supplier.

4.3 Test methods included in this standard are indicated in **Table 1** by showing the applicable section numbers after the suffix letter.

4.4 In cases involving referee decisions, SI units shall be used.

5. Significance and Use

5.1 The test procedures provide a standard method of obtaining data for research and development, quality control, acceptance and rejection under specifications, and special purposes.

5.2 The data obtained by these test methods are applicable to the material under conditions of the particular test and are not necessarily the same as obtained in other environments or use conditions.

6. Sampling

6.1 When possible, use the completed manufactured product for the tests specified. Randomly select representative samples of the lot being examined, as required.

6.2 Extruded or molded shapes or sizes too small for cutting standard test specimens are difficult to classify or test by these test methods and will usually require special testing procedures or the use of standard test sheets.

6.3 When it is necessary or advisable to obtain test specimens from the article, as in those cases where the entire sample is not required or adaptable for testing, specify the method of cutting and the exact position from which specimens are to be taken. It is possible that the apparent density and the state of crosslinking will vary in different parts of the finished product, especially if the article is of complicated shape or of varying thickness, and these factors affect the physical properties of the specimens. Also, the apparent density is affected by the number of cut surfaces as opposed to the number of skin-covered surfaces on the test specimen.

6.4 When the finished product does not lend itself to testing or to the taking of test specimens because of complicated shape, small size, metal or fabric inserts, solid covers, adhesion to metal, or other reasons, prepare standard test sheets. When differences due to the difficulty in obtaining suitable test specimens from the finished part arise, the manufacturer and purchaser may agree on acceptable deviations. This can be done by comparing the results of standard test specimens and those obtained on actual parts.

6.5 If the material to be tested is anisotropic, prepare the test specimens so as to measure the property in the direction of interest in the application.

7. Conditioning

7.1 Conduct tests under known conditions of temperature and humidity or as specified in the individual test procedure. In case of dispute, conduct the test at a temperature of $23 \pm 2^\circ\text{C}$ ($73.4 \pm 3.6^\circ\text{F}$) and in an atmosphere of $50 \pm 10\%$ relative humidity. The product shall be conditioned, undeflected, and undistorted, at the temperature and humidity of test for at least 24 h before being tested.

7.2 It is recommended, for referee purposes, that all tests shall be performed 96 h or more after the foam has been manufactured.

TABLE 1 Suffix Letter Designations

NOTE 1—These suffix letters have been assigned by Subcommittee D11.33 and are consistent with those in Specifications **D1056** and **D1667**.

| Suffix Letter | Property | Section |
|---------------|---|------------------|
| A | Heat resistance | |
| B | Compression set under constant deflection | 9 – 16 |
| C | Ozone or weather resistance | |
| D | Compression deflection | 17 – 24 |
| E | Oil resistance | |
| F | Low temperature | |
| G | Tear resistance | 25 |
| H | Flex resistance | |
| I | Not assigned because of similarity to numeral 1 | |
| J | Abrasion resistance | |
| K | Adhesion capability | |
| L | Water absorption | 26 – 32 |
| M | Flammability resistance | 33 |
| N | Impact resistance | |
| O | Electrical properties | |
| P | Staining resistance | |
| Q | Not assigned because of similarity to letter O | |
| R1 | Resilience | |
| R2 | Energy absorption | 34 |
| S | Thermal stability | 35 – 42 |
| T | Tensile strength and elongation | 43 |
| U | Not assigned | |
| V | Thermal conductivity | 44 and 45 |
| W | Density | 46 – 48 and 64.5 |
| X | Not assigned | |
| Y | Not assigned | |
| Z | Special requirements | |
| AA | Buoyancy | 49 – 54 and 64.6 |
| BB | Constant compressive creep | 55 – 62 |
| CC | Dynamic cushioning | 63 and 64.7 |
| DD | Open cell | |
| EE | Not assigned | |
| FF | Water vapor transmission | |

8. Measurement of Test Specimens

8.1 Measure dimensions up to and including 25.4 mm (1 in.) using a dial-type gauge with a minimum foot area of 645.1 mm² (1 in.²). Hold the pressure on the foot to a maximum of 800 Pa (0.116 psi).

NOTE 2—Thickness of materials having irregular surface characteristics shall be measured as agreed upon between the purchaser and the supplier.

8.2 Dimensions over 25.4 mm (1 in.) shall be measured with a dial or digital gauge, scale, or tape. Take care not to distort the test specimen.

8.3 The scale, tape, or gauge shall be graduated to permit measurements within $\pm 1\%$ of the dimension to be measured.

8.4 Results reported shall be the average of a minimum of three equally spaced measurements of length and width and for thickness shall be the average of the center and four equally spaced measurements around the perimeter of the specimens.

Suffix Tests Suffix B—Compression Set Under Constant Deflection

9. Scope

9.1 This test method covers the deflection of the foam specimen under a compressive force and under specified conditions of time and temperature, then noting the effect on the thickness of the specimen after releasing the compressive force.

9.2 *This international standard was developed in accordance with internationally recognized principles on standardization established in the Decision on Principles for the Development of International Standards, Guides and Recommendations issued by the World Trade Organization Technical Barriers to Trade (TBT) Committee.*

10. Apparatus

10.1 *Compression Device*, consisting of two or more flat steel or aluminum plates that are of sufficient thickness to prevent deflection of the plates under load. The plates are held parallel to each other by bolts or clamps, and the space between the plates is adjustable to the required deflection thickness by means of spacers.

11. Test Specimens

11.1 The test specimens shall have parallel top and bottom surfaces and essentially perpendicular sides.

11.2 Specimens shall be 50.8 by 50.8 by 25.4 mm (2 by 2 by 1 in.) unless otherwise specified. Specimens less than 25.4 mm in thickness shall be plied up, without the use of an adhesive, to produce a total thickness of 25.4 mm.

NOTE 3—To obtain accurate data when testing foams with large cells or irregular surfaces, or both, larger samples approximately 101.6 by 101.6 by 25.4 mm (4 by 4 by 1 in.) are recommended.

12. Number of Specimens

12.1 Test three specimens for each sample. The values reported shall be the mean of those observed. If any value

deviates more than 20 % from this mean, test two additional specimens and report the mean for all five values.

13. Procedure

13.1 Perform the entire test procedure at $23 \pm 2^\circ\text{C}$ ($73.4 \pm 3.6^\circ\text{F}$).

NOTE 4—See Practice D1349 if conditions other than these are desired.

13.2 Measure the test specimen original thickness (t_o) in accordance with the procedure in Section 8.

13.3 Place the test specimen or specimens in the apparatus in a manner that will not allow the specimens to come into contact with each other upon being compressed and deflect the specimens to $50\% \pm 1\%$ of their thickness.

13.4 Allow the test specimen to remain deflected in the apparatus for $22\text{ h} \pm 30\text{ minutes}$.

13.5 Remove the specimen from the test apparatus at the end of the 22-h period. Measure the final thickness (t_f) after $24\text{ h} \pm 30\text{ minutes}$ of recovery.

14. Calculation

14.1 Calculate the constant deflection compression set, expressed as a percentage of the original thickness, as follows:

$$C_d = \frac{(t_o - t_f)}{t_o} \times 100 \quad (1)$$

where:

C_d = compression set expressed as a percent of the original thickness,
 t_o = original thickness, mm (in.), and
 t_f = thickness of the specimen after the specified recovery period, mm. (in.)

15. Report

15.1 The original and final thicknesses of the three specimens to the nearest 0.0254 mm (0.001 in.).

15.2 The average compression set value, of the three specimens tested to the nearest 0.1 % for each sample, except as noted in 13.1.

16. Precision and Bias

16.1 See Section 64 for precision and bias data.

Suffix D—Compression Deflection (Also called Load Deflection or Compressive Strength)

17. Scope

17.1 This test method covers the measurement of the force necessary to produce a 25 % compression over the entire top area of the foam specimen.

NOTE 5—Compression deflection tests other than at 25 % may be specified as agreed upon between the purchaser and the supplier.

17.2 *This international standard was developed in accordance with internationally recognized principles on standardization established in the Decision on Principles for the Development of International Standards, Guides and Recommendations issued by the World Trade Organization Technical Barriers to Trade (TBT) Committee.*

18. Apparatus

18.1 An apparatus shall be capable of compressing the specimen between a flat supporting plate and a flat compression foot, larger than the specimen to be tested, at a uniform speed of 31.75 ± 12.7 mm/min (1.25 ± 0.5 in./min). The apparatus shall be capable of measuring the force required to produce the specified compression and the displacement of the compression foot.

19. Test Specimens

19.1 The test specimen shall be 50.8 by 50.8 by 25.4 mm (2 by 2 by 1 in.), unless otherwise specified, with parallel top and bottom surfaces. Tolerances for the dimensions shall be ± 1.27 mm (0.050 in.). Specimens less than 25.4 mm thick shall be plied up, without the use of cement, to a minimum of 25.4 mm.

NOTE 6—Specimens less than 25.4 mm (1 in.) thick may be tested without being plied up, but the thickness must be specified.

20. Number of Specimens

20.1 Test three specimens for each sample. The values reported shall be the mean of those observed. If any value deviates more than 20 % from this mean, test two additional specimens and report the mean for all five values.

21. Procedure

21.1 Place the specimen centered in the line of the axial load on the supporting plate of the apparatus.

21.2 Bring the compression foot into contact with the specimen and determine the thickness after applying a total pretest-pressure of 190 ± 50 Pa (0.028 ± 0.007 psi) to the specimen area. Compress the specimen 25 ± 0.5 % of this thickness at 12.7 ± 1 mm/min (0.5 ± 0.039 in./min) and take the reading of the load immediately, unless another speed is specified.

NOTE 7—Where foam is appreciably compressed by this pretest-pressure, foot area and loading shall be as agreed upon between the purchaser and the supplier.

22. Calculation

22.1 Calculate the 25 % compression deflection stress, per unit area of specimen, expressed as kilopascals or psi, as follows:

$$CD = \frac{F}{A} \quad (2)$$

where:

- CD = compression deflection stress per unit of specimen area, kPa (psi),
- F = force required to compress the specimen 25 % of the thickness as measured in 8.2, kN (lbf), and
- A = specimen contact surface area, m² (in.²).

23. Report

23.1 The average thickness of the three specimens to the nearest 0.0254 mm (0.001 in).

23.2 The average area of the three specimens to the nearest 0.645 mm² (0.001 in.²).

23.3 The average compression deflection of the three specimens in kPa or psi to the nearest 0.1, except as noted in 20.1.

24. Precision and Bias

24.1 See Section 64 for precision and bias data.

Suffix G—Tear Resistance, Test Method D624

25. Test Method D624

25.1 Die C shall be used.

25.2 Test the material at the thickness to be supplied, unless otherwise arranged by agreement between the purchaser and the supplier.

Suffix L—Water Absorption

26. Scope

26.1 This test method covers the measurement of the water absorbed by olefin polymer flexible cellular materials during submersion under pressure.

26.2 *This international standard was developed in accordance with internationally recognized principles on standardization established in the Decision on Principles for the Development of International Standards, Guides and Recommendations issued by the World Trade Organization Technical Barriers to Trade (TBT) Committee.*

27. Test Specimens

27.1 Test specimens shall be 101.6 by 101.6 mm (4 by 4 in.) by the thickness of material being supplied. Unless otherwise specified, the presence of skin on the top or bottom surfaces shall be optional.

28. Number of Specimens

28.1 Test three specimens for each sample. The values reported shall be the mean of those observed. If any value deviates more than 20 % from this mean, test two additional specimens and report the mean for all five values.

29. Procedure

29.1 Measure the area of the cut surfaces in accordance with Section 8 and calculate the area of the cut surfaces.

29.2 Weigh the specimens and submerge under a 3 ± 0.1 -m (10-ft \pm 4-in.) head of water (equal to 28.68–31.09 kPa or 4.16–4.51 psi) at $23 \pm 2^\circ\text{C}$ ($73.4 \pm 3.6^\circ\text{F}$) for 48 h \pm 15 min. Then place the specimens in a stream of air for the minimum time required to remove visible water from the surfaces and reweigh.

NOTE 8—To remove visible and entrapped water from the surface and cut edges, direct a stream of air (using approximately 30 psi air pressure) at the surfaces and cut edges at approximately a 45 degree angle and from the distance of approximately 6.35 mm (0.25 in.) from the surface for approximately 4 min.

30. Calculation

30.1 Calculate the water absorption, expressed in kg/m² (lb/ft²) of cut surfaces (surfaces without skin or rind) as follows:

$$\text{Water Absorption} = \frac{W_2 - W_1}{A} \quad (3)$$

where:

- W_1 = specimen mass before immersion, kg (lb),
 W_2 = specimen mass after immersion, kg (lb), and
 A = area of cut surface, m^2 (ft^2).

31. Report

31.1 The initial and final mass of the three specimens to the nearest 0.001 g.

31.2 The average water absorption in kg/m^2 (lb/ft^2) of the three specimens tested to the nearest 0.1, except as noted in 28.1.

32. Precision and Bias

32.1 See Section 64 for precision and bias data.

Suffix M—Flammability Ease of Ignition

33. See Test Method D2863

Suffix R₂—Energy Absorption

34. See Test Method F355

34.1 Procedure A of Test Method F355 shall be used.

34.2 The impact velocity shall be 3.45 ± 0.17 m/s.

NOTE 9—Approximate drop height is 60 cm (24 in.).

34.3 Conduct the test at $23 \pm 2^\circ\text{C}$ ($73.4 \pm 3.6^\circ\text{F}$).

34.4 The test specimens shall be 25.4 mm (1 in.) thick.

Suffix S—Thermal Stability

35. Scope

35.1 This test method covers the determination of dimensional stability of foam in any direction, at elevated temperature.

35.2 *This international standard was developed in accordance with internationally recognized principles on standardization established in the Decision on Principles for the Development of International Standards, Guides and Recommendations issued by the World Trade Organization Technical Barriers to Trade (TBT) Committee.*

36. Apparatus

36.1 *Oven*, circulating-air, capable of holding the set temperature to a tolerance of $\pm 1\%$.

37. Test Specimen

37.1 The test specimens shall be 254 by 254 by 25.4 mm (10 by 10 by 1 in.). Where finished goods with smaller than the specified test specimen are to be tested, the full available dimensions shall be used.

NOTE 10—An alternative test method is to cut 304.8 by 304.8-mm (12 by 12-in.) specimens and mark off the 254 by 254-mm (10 by 10-in.) dimensions.

38. Number of Specimens

38.1 A single specimen shall be tested for each sample.

39. Procedure

39.1 Determine all three dimensions in accordance with the procedure in Section 8.

39.2 Adjust the oven temperature to $70 \pm 2^\circ\text{C}$ ($158 \pm 3.6^\circ\text{F}$).

39.3 Expose the test specimen in the oven at the above temperature for $24 \text{ h} \pm 15$ minutes.

39.4 Remove the test specimen and allow to cool at $23 \pm 2^\circ\text{C}$ ($73.4 \pm 3.6^\circ\text{F}$) for $2 \text{ h} \pm 15$ minutes.

39.5 Determine all three dimensions at the end of the cooling period.

40. Calculation

40.1 Calculate the dimensional change for each dimension as a percent of original as follows:

$$\% \text{ dimensional change} = \frac{L_f - L_o}{L_o} \times 100 \quad (4)$$

where:

- L_o = original dimension, mm (in.), and
 L_f = dimension at end of test, mm (in.).

41. Report

41.1 The dimensional change of each direction of interest as a percent of the original dimension to the nearest 0.1 %.

41.2 The shrinkage as negative values and growth as positive values.

42. Precision and Bias

42.1 See Section 64 for precision and bias data.

Suffix T—Tensile Strength and Elongation

43. See Test Methods D412

43.1 The samples shall be cut using the Die A, as described in Test Methods D412.

43.2 Test the material in the thickness to be supplied, unless otherwise agreed upon between the purchaser and the supplier.

Suffix V—Thermal Conductivity

44. Test Method A

44.1 See Test Method C177.

45. Test Method B

45.1 See Test Method C518.

Suffix W—Density

46. Test Method A

46.1 *Scope*—This test method covers the determination of density of foam by calculation from the mass and volume of a regularly shaped specimen.

46.2 *Test Specimen*—A representative test specimen of regular shape, not less than 16.4 cm³ (1 in.³) shall be cut from the sample to be tested.

NOTE 11—Larger specimens may be necessary when testing coarse cell foams.

46.3 *Number of Specimens*—Three specimens shall be tested for each sample.

46.4 *Procedure:*

46.4.1 Weigh the specimen on a balance or scale graduated so as to permit weighing within ±1 % of the mass to be measured.

46.4.2 Determine the dimensions of the specimen in accordance with Section 8.

46.5 *Calculation*—Calculate the density as follows:

$$D = \frac{m}{v} \quad (5)$$

where:

D = density, kg/m³ (lb/ft³),

m = mass, kg (lb), and

v = volume, m³ (ft³).

46.6 *Report*—Report density to the nearest 1.0 kg/m³ (0.1 lb/ft³).

46.6.1 The mass of each specimen to the nearest 0.001g.

46.6.2 The volume of each specimen to the nearest 1 mm³ or 0.001 in.³.

46.6.3 The average density of three specimens in (kg/m³) lb/ft³ to the nearest 0.1.

47. Precision and Bias

47.1 See Section 64 for precision and bias data.

48. Test Method B

48.1 *Scope*—This test method covers the determination of the density of closed-cell foams where the volume is determined by a liquid displacement method and mass.

NOTE 12—This test method is particularly appropriate when testing small or irregularly shaped samples.

48.2 *Apparatus:*

48.2.1 *Scale or Balance.*

48.2.2 *Immersion Vessel*, as shown in Fig. 1.

48.2.3 *Receiving Vessel*, as shown in Fig. 1.

48.3 *Test Specimen*—Cut a representative test specimen not less than 16.4 cm³ (1 in.³) from the sample to be tested.

NOTE 13—Larger specimens may be necessary when testing coarse cell foams or foams with irregular surfaces.

48.4 *Number of Specimens*—Test three specimens for each sample.

48.5 *Procedure:*

48.5.1 Weigh the specimen on a balance or scale graduated so as to permit weighing within ±1 % of the mass to be measured.

48.5.2 Fill the immersion vessel with liquid until it overflows. Insert the lid in the vessel.

48.5.3 Determine the tare mass of the receiving vessel and, when the flow rate has decreased to less than two drops per minute, place under the overflow spout of the immersion vessel.

48.5.4 Remove the lid, place the test specimen in the immersion vessel, and replace the lid.

48.5.5 When the flow rate has decreased to less than two drops per minute, weigh the receiving vessel.

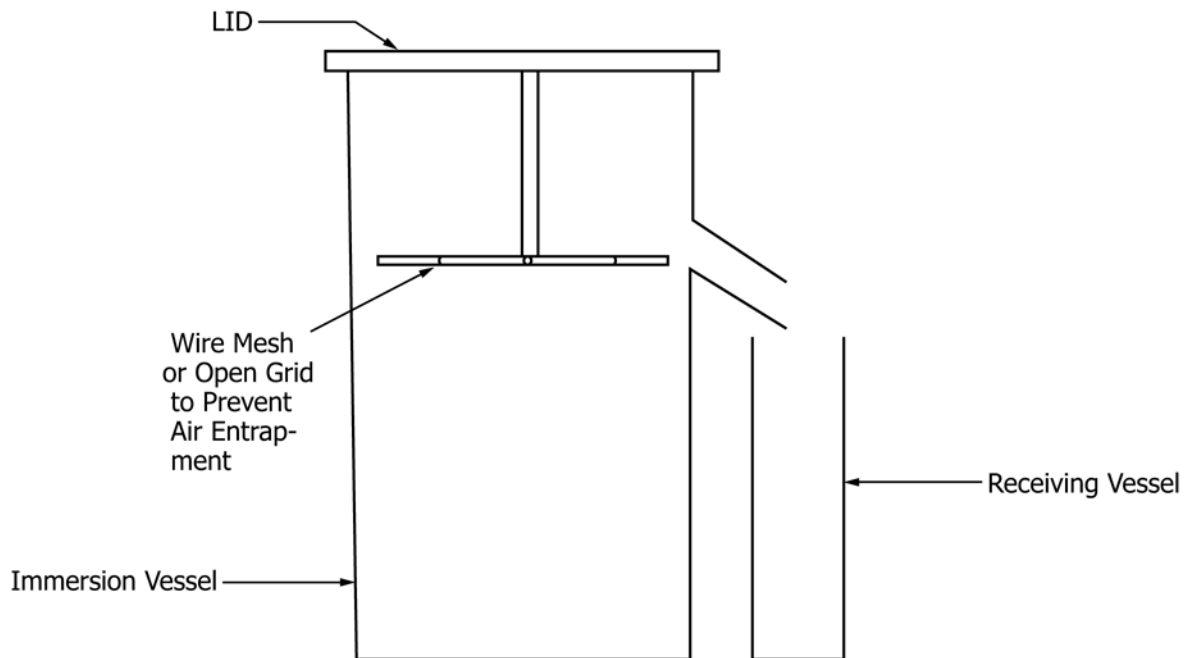

FIG. 1 Apparatus for Density Test Method B