



Designation: C497M – 20

Standard Test Methods for Concrete Pipe, Concrete Box Sections, Manhole Sections, or Tile (Metric)¹

This standard is issued under the fixed designation C497M; the number immediately following the designation indicates the year of original adoption or, in the case of revision, the year of last revision. A number in parentheses indicates the year of last reapproval. A superscript epsilon (ϵ) indicates an editorial change since the last revision or reapproval.

This standard has been approved for use by agencies of the U.S. Department of Defense.

1. Scope

1.1 These test methods cover testing of concrete pipe, concrete box sections, manhole sections, and tile. The test methods described are used in production testing and acceptance testing to evaluate the properties provided for in the specifications.

1.2 The test methods appear in the following order:

	Section
External Load Crushing Strength	4
Flat Slab Top	5
Base Section Test	6
Core Strength	7
Absorption	8
Hydrostatic	9
Permeability	10
Manhole Step	11
Cylinder	12
Gasket Lubricant	13
Joint Shear	14
Alkalinity	15
Gasket Measurements	16
Off-Center Hydrostatic Joint Test	17
Hydrostatic External Joint Test Method	18
Welded Splice Pull Test	19

1.3 The test specimens shall not have been exposed to a temperature below 4°C for the 24 h immediately preceding the test.

1.4 If any test specimen fails because of mechanical reasons such as failure of testing equipment or improper specimen preparation, it shall be discarded and another specimen taken.

1.5 Specimens shall be selected in accordance with the specifications for the type of pipe or tile being tested.

1.6 These methods are the metric companion of Test Methods C497.

1.7 *This standard does not purport to address all of the safety concerns, if any, associated with its use. It is the responsibility of the user of this standard to establish appropriate*

¹ These test methods are under the jurisdiction of ASTM Committee C13 on Concrete Pipe and are the direct responsibility of Subcommittee C13.09 on Methods of Test.

Current edition approved Feb. 15, 2020. Published March 2020. Originally approved in 1980. Last previous edition approved in 2019 as C497M – 19a. DOI: 10.1520/C0497M-20.

appropriate safety, health, and environmental practices and determine the applicability of regulatory limitations prior to use.

1.8 *This international standard was developed in accordance with internationally recognized principles on standardization established in the Decision on Principles for the Development of International Standards, Guides and Recommendations issued by the World Trade Organization Technical Barriers to Trade (TBT) Committee.*

2. Referenced Documents

2.1 ASTM Standards:²

- C31/C31M Practice for Making and Curing Concrete Test Specimens in the Field
- C39/C39M Test Method for Compressive Strength of Cylindrical Concrete Specimens
- C42/C42M Test Method for Obtaining and Testing Drilled Cores and Sawed Beams of Concrete
- C617 Practice for Capping Cylindrical Concrete Specimens
- C670 Practice for Preparing Precision and Bias Statements for Test Methods for Construction Materials
- C822 Terminology Relating to Concrete Pipe and Related Products
- C1231/C1231M Practice for Use of Unbonded Caps in Determination of Compressive Strength of Hardened Cylindrical Concrete Specimens
- D2240 Test Method for Rubber Property—Durometer Hardness
- E4 Practices for Force Verification of Testing Machines

3. Terminology

3.1 *Definitions*—For definitions of terms relating to concrete pipe, see Terminology C822.

4. External Load Crushing Strength Test by the Three-Edge Bearing Test Method

4.1 *Summary of Test Method*—The test specimen is tested in a machine designed to apply a crushing force upon the

² For referenced ASTM standards, visit the ASTM website, www.astm.org, or contact ASTM Customer Service at service@astm.org. For *Annual Book of ASTM Standards* volume information, refer to the standard's Document Summary page on the ASTM website.

specimen in a plane through the vertical axis extending along the length of the specimen.

4.2 *Significance and Use*—The crushing test method shall be either a quality control test performed to establish that the finished, shippable pipe has sufficient strength to withstand the crushing loads stated in the specifications or a proof of design test performed to prove the adequacy of design.

4.3 *Apparatus:*

4.3.1 The testing machine shall be of any type of sufficient capacity and shall be capable of providing the rate of loading prescribed in 4.5.3.

4.3.2 The testing machine shall be substantial and rigid throughout, so that the distribution of the load will not be affected appreciably by the deformation or yielding of any part.

4.3.3 The three-edge-bearing method of loading shall be used. The test specimen shall be supported on a lower bearing of two parallel longitudinal strips and the load applied through an upper beam (Fig. 1, Fig. 2, Fig. 3, and Fig. 4). At the option of the manufacturer, either or both the lower bearing and the upper bearing shall extend the full length or any portion of the length of the specimen.

4.3.4 The lower bearings shall consist of wood or hard rubber strips. Wooden strips shall be straight, have a cross section of not less than 50 mm in width and not less than 25 mm nor more than 38 mm in height and shall have the top inside corners rounded to a radius of 13 mm. Hard rubber strips shall have a durometer hardness of not less than 45 nor more than 60. They shall be rectangular in cross section, having a width of not less than 50 mm, a thickness of not less than 25 mm nor more than 38 mm, and shall have the top inside corner rounded to a radius of 13 mm.

4.3.5 The lower bearing strips shall be fastened to a wooden or steel beam or directly to a concrete base, any of which shall provide sufficient rigidity so that the deflection is not greater than $\frac{1}{720}$ of the specimen length when the maximum load is applied. The rigid base shall be at least 150 mm wide. The interior vertical sides of the strips shall be parallel and spaced a distance apart of not more than 25 mm per 300 mm of specimen diameter, but in no case less than 25 mm. The bearing faces of the lower strips shall not vary from a straight line vertically or horizontally by more than 2.5 mm/m of length under no load.

4.3.6 The upper bearing shall be a rigid wood beam with or without an attached hard rubber strip. The wood shall be sound, free of knots, and straight and true from end to end. It shall be fastened to a steel or wood-faced steel beam of such dimensions that deflections under maximum load will not be greater than $\frac{1}{720}$ of the specimen length. The bearing face of the upper bearing shall not deviate from a straight line by more than 2.5 mm/m of length. When a hard rubber strip is used on the bearing face it shall have a durometer hardness of not less than 45 nor more than 60, and shall have a width of not less than 50 mm and a thickness of not less than 25 mm nor more than 38 mm and shall be secured to a wood beam meeting the above requirements.

4.3.7 If mutually agreed upon by the manufacturer and the owner prior to the test, before the specimen is placed, a fillet of plaster of paris not exceeding 25 mm in thickness shall be cast on the surface of the upper and lower bearings. The width of the fillet cap, upper or lower, shall be not more than 80 mm/m of the specimen diameter, but in no case less than 25 mm.

4.3.8 The equipment shall be so designed that the load will be distributed about the center of the overall length (L_f) of the specimen (Fig. 1, Fig. 2, Fig. 3, and Fig. 4). At the option of the manufacturer, the center of the load shall be applied at any point of the overall length (L_f) of the specimen. The load shall be applied either at a single point or at multiple points dependent on the length of the specimen being tested and the rigidity of the test frame.

NOTE 1—The user of these test methods is advised that multiple points of load applications to the upper bearing will permit use of lighter beams without excessive deflection.

4.4 *Calibration*—The loading device shall be one which shall provide an accuracy of $\pm 2\%$ at the specified test loads. A calibration curve shall be used. The machines used for performing the three-edge-bearing tests shall be verified in accordance with Practices E4.

4.5 *Conditioning*—The moisture requirements of 1.3 are not required, at the option of the manufacturer.

4.6 *Procedure:*

4.6.1 Place the specimen on the two lower bearing strips in such a manner that the pipe or tile rests firmly and with uniform bearing on each strip.

4.6.2 Mark the two ends of the specimen at a point midway between the lower bearing strips and then establish the diametrically opposite point on each end. Place the upper bearing so that it is aligned with these marks.

4.6.3 For reinforced concrete pipe, any rate or load application up to a maximum of 109.4 kN/linear metre of pipe per minute shall be used up to 75 % of the specified design strength, at which time the rate of loading shall be reduced to a maximum uniform rate of 43.8 kN/linear metre of pipe per minute. If both the design strength and the ultimate strength are being determined, a specified rate of loading need not be maintained after the design strength has been reached. For nonreinforced concrete pipe, any rate of load application up to a maximum of 109.4 kN/linear metre of pipe per minute shall be used up to 75 % of the specified ultimate strength, at which time the rate of loading shall be reduced to the maximum uniform rate of 43.8 kN/linear metre of pipe per minute.

4.6.4 As defined in Terminology C822, the design strength is the maximum load, expressed as a D-load, supported by the pipe before a crack having a width of 0.3 mm occurs throughout a continuous length of 300 mm or more measured parallel to the longitudinal axis of the pipe barrel. The crack is 0.3 mm in width when the point of the measuring gauge will, without forcing, penetrate 1.5 mm at 75 mm maximum intervals, throughout the specified distance of 300 mm. Measure the width of the crack by means of a gauge made from a leaf in thickness (as in a set of standard machinist gauges),

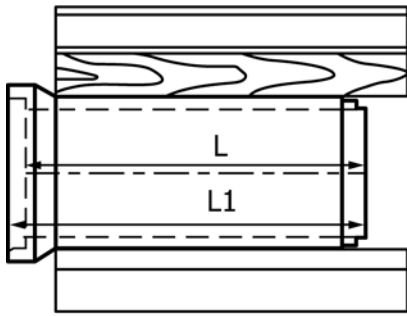

BELL AND SPIGOT OR MODIFIED TONGUE AND GROOVE PIPE

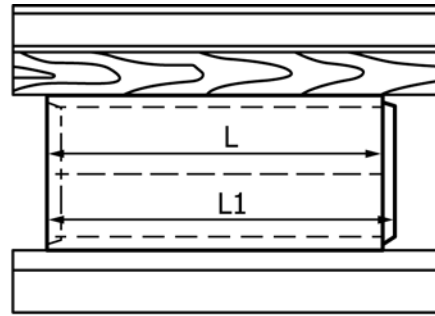

TONGUE AND GROOVE OR STRAIGHT WALL PIPE

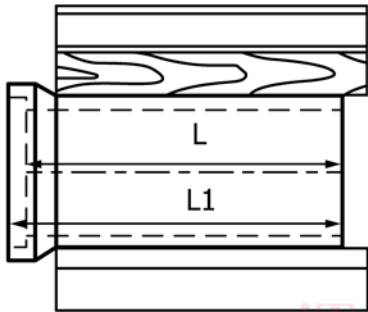

BELL AND PLAIN END PIPE

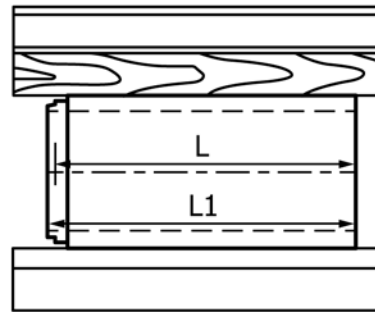

SPIGOT AND PLAIN END PIPE

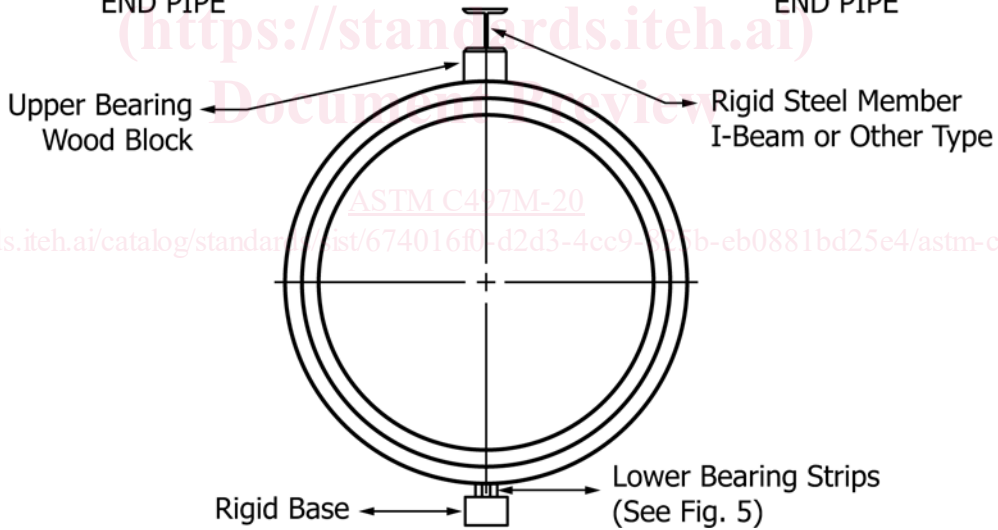

NOTE 1—The figures illustrate a method of applying the load to the pipe

FIG. 1 Three-Edge-Bearing Test, Circular Pipe

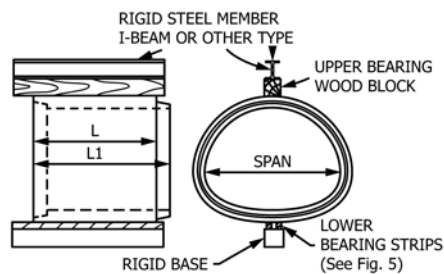

NOTE 1—The figure illustrates a method of applying the load to the pipe.

FIG. 2 Three-Edge-Bearing Test, Arch Pipe

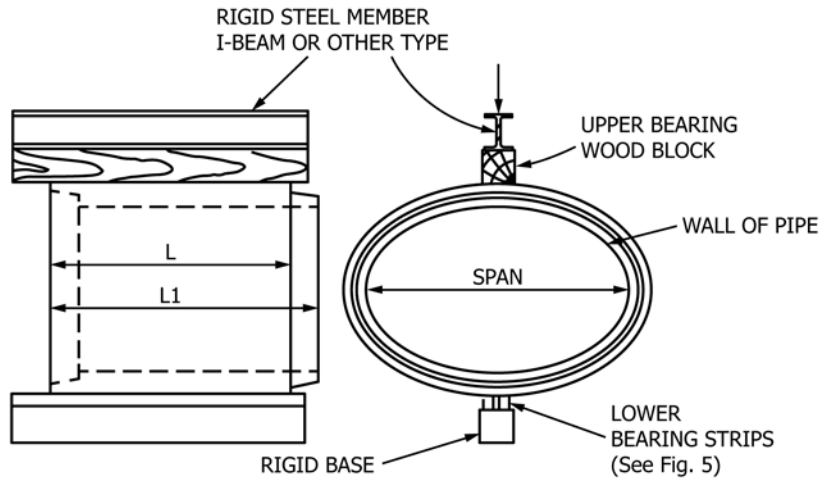

NOTE 1—The figure illustrates a method of applying the load to the pipe.
FIG. 3 Three-Edge-Bearing Test, Horizontal Elliptical Pipe

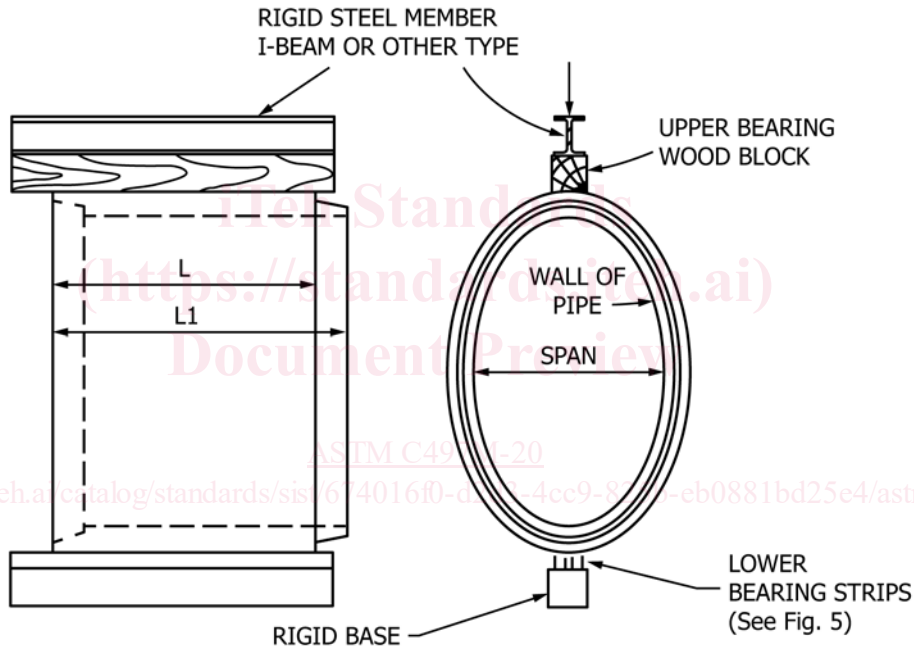

NOTE 1—The figure illustrates a method of applying the load to the pipe. Three-Edge-Bearing Test, Vertical Elliptical Pipe
FIG. 4 Three-Edge-Bearing Test, Vertical Elliptical Pipe

ground to a point of 1.5 mm in width with corners rounded and with a taper of 0.25 mm/mm as shown in Fig. 6.

NOTE 2—As used in this specification, the 0.3-mm crack is a test criterion for pipe tested in three-edge bearing test and is not intended as an indication of overstressed or failed pipe under installed conditions.

4.6.5 As defined in Terminology C822, the ultimate strength is the maximum load supported by the pipe.

NOTE 3—Ultimate strength of concrete pipe in the buried condition is dependent on varying soil bedding factors and varying failure modes and shall have no relationship to the ultimate strength as defined under three-edge bearing conditions.

4.7 Calculations:

4.7.1 Strength test results shall be calculated in terms of pounds per linear foot. The length used in calculating the

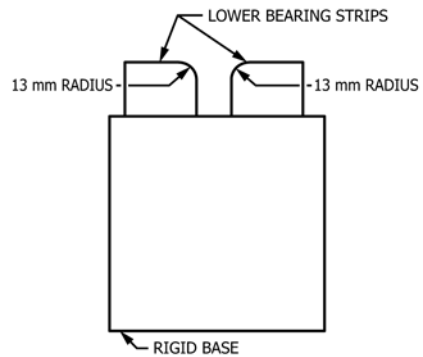

FIG. 5 Lower Bearing Strip Detail

strength values shall be that indicated by the manufactured

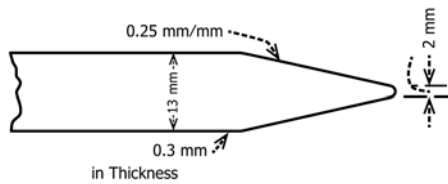

FIG. 6 Gauge Leaf for Measuring Cracks

length (L) in Figs. 1-4. For pipe with a bell, the manufactured length (L) is the length from the spigot/tongue end face to the bell/groove inside shoulder. For straight wall pipe, no bell, the manufactured length (L) is the same as for pipe with a bell or the alternate of the length from the spigot/tongue outside shoulder to the socket/groove end face. For plain end or cut pipe, no bell or spigot, the manufactured length (L) is the same as the overall length (L_1). For pipe having a spigot on one end with the opposite end being plain, the manufactured length (L) shall be the distance from the plain end to the center of the joint. For pipe having a bell on one end with the opposite end being plain, the manufactured length (L) shall be the distance from the plain end to the bell inside shoulder. See Terminology C822 for definitions of manufactured length (L) and overall length (L_1).

4.7.2 The ultimate strength in pounds per linear metre shall be calculated by dividing the maximum test load applied to the pipe by the manufactured length, (L).

4.7.3 The D-load strength in newtons per linear metre per millimetre of inside diameter or horizontal span shall be either the 0.3-mm crack D-load strength or the ultimate D-load strength. The 0.3-mm crack D-load shall be calculated by dividing the test load required to produce the 0.3-mm crack by the manufactured length, (L), and by the pipe inside diameter or horizontal span. The ultimate D-load strength shall be calculated by dividing the ultimate test load applied to the pipe by the manufactured length, (L), and by the pipe inside diameter or horizontal span.

4.8 Precision and Bias—The user of these test methods is advised that the true value for the strength of a concrete pipe cannot be determined because the specimen is tested to destruction and exact duplicate specimens cannot be obtained.

Therefore, no calculations of precision and bias are presently possible. Specifications that include this test method for the various types of concrete pipe should include a provision for additional tests of one or more specimens.

5. Flat Slab Top Test Method

5.1 Summary of Test Method—A load is applied to the flat slab top and the supporting capacity of the flat slab top is measured.

5.2 Significance and Use—The test method is a proof of design test performed to prove the adequacy of the design.

5.3 Conditioning—The moisture requirements of 1.3 are not required, at the option of the manufacturer.

5.4 Procedure—Place the section that has been designated to receive the flat slab top on a firm, even surface. Assemble the flat slab top to this section. If a frame or riser has been designed to be fitted to the access portion of the flat slab top, assemble it to the slab top. Apply the test load to the riser or frame as assembled to the flat slab top. If no access opening has been provided to the flat slab top, apply the test load to the center of the flat slab top by means of a 300 by 300 by 100-mm wood bearing block. See Fig. 7. Calculate the test load as follows:

$$P_u = 1.3 D + 2.17L(1 + I) \quad (1)$$

where:

- P_u = applied minimum ultimate proof-of-design test load, N,
- D = total calculated field dead load on the slab, N,
- L = calculated live load on the flat slab top, and
- I = impact factor, 30 % minimum.

6. Base Section Test Method

6.1 Summary of Test Method—A load is applied to the base section and the supporting capacity of the base section is measured (See 1.7 for safety concerns).

6.2 Significance of Use—The test method is a proof of design test performed to prove the adequacy of the design.

6.3 Conditioning—The temperature requirements of 1.3 are not required, at the option of the manufacturer.

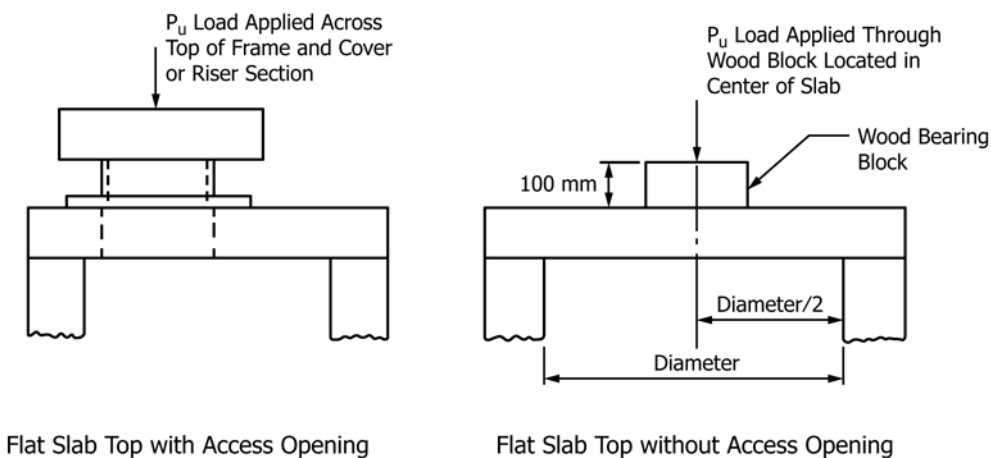

FIG. 7 Flat Slab Top Test

TYPES OF BASE SECTIONS

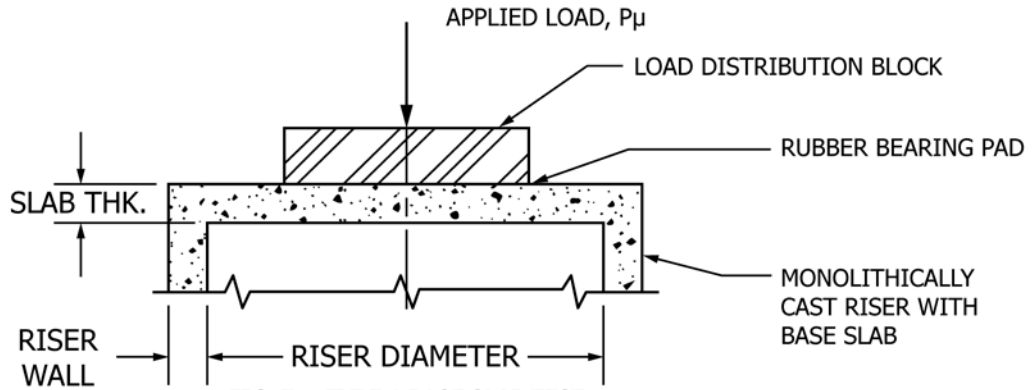

FIG. 7c - TYPE 1 BASE SLAB TEST

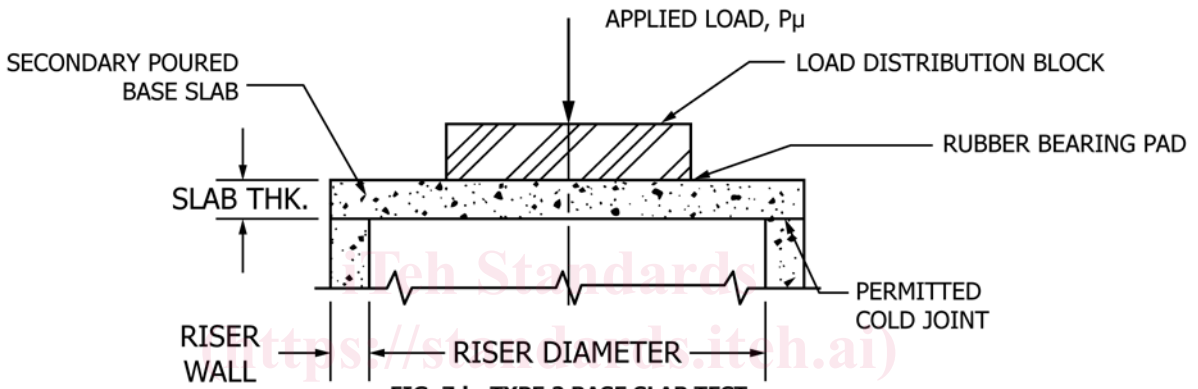

FIG. 7d - TYPE 2 BASE SLAB TEST

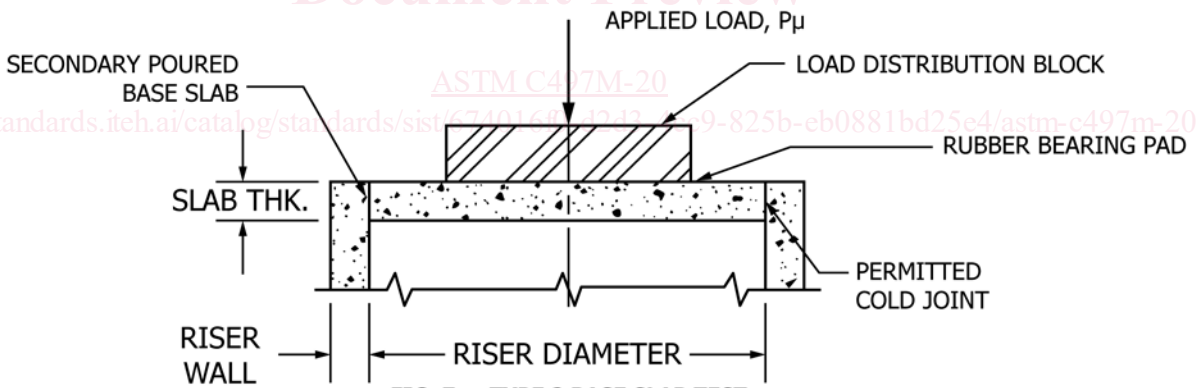

FIG. 7e - TYPE 2 BASE SLAB TEST

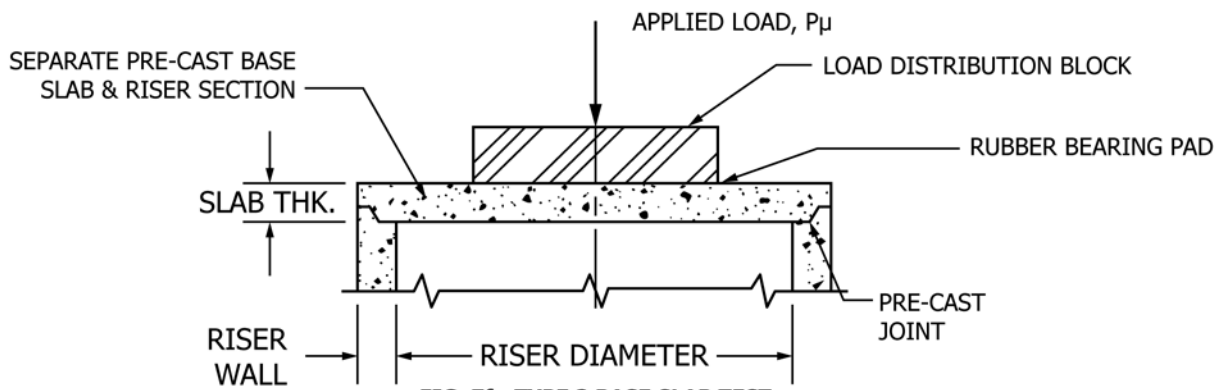

FIG. 7f - TYPE 3 BASE SLAB TEST

FIG. 7 Flat Slab Top Test (continued)