

INTERNATIONAL
STANDARD

ISO
4622

Second edition
1992-12-15

**Paints and varnishes — Pressure test for
stackability**

iTeh *Peintures et vernis — Essai de pression pour aptitude à l'empilement*
(standards.iteh.ai)

ISO 4622:1992

<https://standards.iteh.ai/catalog/standards/sist/8df7324a-c65b-4e02-b1da-71400d752943/iso-4622-1992>



Reference number
ISO 4622:1992(E)

Foreword

ISO (the International Organization for Standardization) is a worldwide federation of national standards bodies (ISO member bodies). The work of preparing International Standards is normally carried out through ISO technical committees. Each member body interested in a subject for which a technical committee has been established has the right to be represented on that committee. International organizations, governmental and non-governmental, in liaison with ISO, also take part in the work. ISO collaborates closely with the International Electrotechnical Commission (IEC) on all matters of electrotechnical standardization.

Draft International Standards adopted by the technical committees are circulated to the member bodies for voting. Publication as an International Standard requires approval by at least 75 % of the member bodies casting a vote.

International Standard ISO 4622 was prepared by Technical Committee ISO/TC 35, *Paints and varnishes*, Sub-Committee SC 9, *General test methods for paints and varnishes*.

This second edition cancels and replaces the first edition (ISO 4622:1980), which has been technically revised. The only technical change is that provisions are now included for larger test pieces.

Annex A forms an integral part of this International Standard.

© ISO 1992

All rights reserved. No part of this publication may be reproduced or utilized in any form or by any means, electronic or mechanical, including photocopying and microfilm, without permission in writing from the publisher.

International Organization for Standardization
Case Postale 56 • CH-1211 Genève 20 • Switzerland

Printed in Switzerland

Paints and varnishes — Pressure test for stackability

1 Scope

This International Standard is one of a series of standards dealing with the sampling and testing of paints, varnishes and related products.

This International Standard specifies a test method for determining, under standard conditions, whether a single-coat film or a multi-coat system of paints or related materials after a specified drying period is sufficiently dry to resist damage when two painted surfaces or one painted surface and another surface are placed in contact under pressure.

The method is intended to simulate the conditions when painted articles are stacked upon each other.

NOTE 1 In some countries, the test is called a "block resistance" test.

2 Normative references

The following standards contain provisions which, through reference in this text, constitute provisions of this International Standard. At the time of publication, the editions indicated were valid. All standards are subject to revision, and parties to agreements based on this International Standard are encouraged to investigate the possibility of applying the most recent editions of the standards indicated below. Members of IEC and ISO maintain registers of currently valid International Standards.

ISO 1512:1991, *Paints and varnishes — Sampling of products in liquid or paste form.*

ISO 1513:1992, *Paints and varnishes — Examination and preparation of samples for testing.*

ISO 1514:—¹⁾, *Paints and varnishes — Standard panels for testing.*

ISO 2808:1991, *Paints and varnishes — Determination of film thickness.*

ISO 3270:1984, *Paints and varnishes and their raw materials — Temperatures and humidities for conditioning and testing.*

3 Required supplementary information

For any particular application, the test method specified in this International Standard needs to be completed by supplementary information. The items of supplementary information are given in annex A.

4 Apparatus

4.1 Test apparatus, as shown in figure 1, consisting of a base-plate and a free-sliding plunger. The plunger, with a head of diameter (50 ± 1) mm, shall have a mass not exceeding 250 g and be designed in such a way that the face of the plunger is aligned with the top surface of the test panel.

NOTE 2 It is recommended that a balljoint connection be present between the plunger and its head.

4.2 Weight, of a mass suitable for the coating and its intended application.

NOTE 3 A mass in the range 100 g to 1 000 g will normally be suitable.

1) To be published. (Revision of ISO 1514:1984)

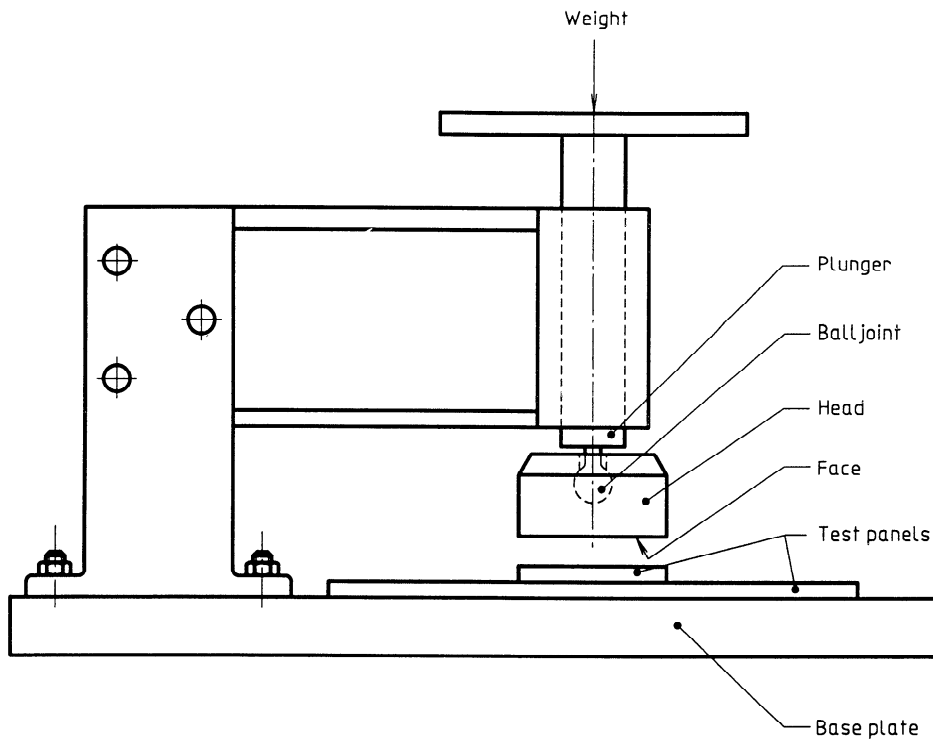

Figure 1 — Example of suitable test apparatus

STANDARD PREVIEW
(standards.iteh.ai)

5 Sampling

Take a representative sample of the product to be tested (or of each product in the case of a multi-coat system), as described in ISO 1512.

Examine and prepare each sample for testing, as described in ISO 1513.

6 Test panel

6.1 Substrate

Unless otherwise agreed, select the substrate from one of those described in ISO 1514 and, where possible, in accordance with the desired practical application.

6.2 Preparation and coating

Unless otherwise agreed, prepare each test panel in accordance with ISO 1514 and then coat it by the specified method with the product or system under test.

6.3 Drying

Dry (or stove) and age (if applicable) each coated test panel for the specified time under the specified conditions.

6.4 Preparation of test pieces

ISO 4622:1992

As soon as possible after the specified drying period, prepare from the test panels at least six strips preferably of width (30 ± 1) mm and length approximately five times the width, in such a manner as to avoid damage to the paint film, to produce the least distortion of the substrate and to ensure that it remains as plane as possible.

Remove any rim raised on the test pieces before testing.

If the preparation of adequate test pieces with dimensions as given above is shown to be impossible because the coating to be tested may be easily damaged, test pieces may be used of dimensions up to $100 \text{ mm} \times 75 \text{ mm}$. In this case, clause 8 shall be applied.

If the interaction between the painted surface and another surface is to be determined, prepare a similar test piece of the other material.

6.5 Thickness of coating

Determine the thickness, in micrometres, of the dried coating by one of the procedures specified in ISO 2808.

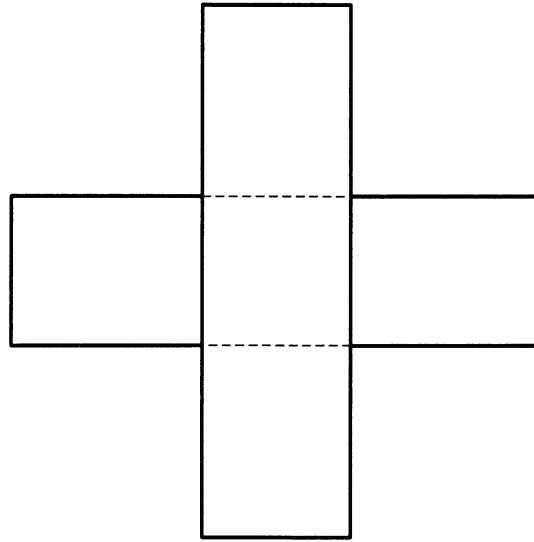

Figure 2 — Plan view of typical arrangement of test pieces

iTeh STANDARD PREVIEW

7 Procedure

7.1 Carry out the procedure in triplicate at $(23 \pm 2)^\circ\text{C}$ and a relative humidity of $(50 \pm 5)\%$, unless otherwise agreed (see also ISO 3270).

7.2 Superimpose the test pieces at $(90 \pm 2)^\circ$ so that the test surfaces are in close contact (see plan view in figure 2). Arrange the test pieces so that the areas least damaged during preparation are superimposed.

NOTE 4 A set square may be used to ensure that the test area is square.

7.3 Place the test pieces on the base plate in such a manner that the plunger covers entirely the contact square. Place the agreed weight on the plunger and gently place the total mass in contact with the test pieces. Allow it to remain there for the specified time.

7.4 At the end of this period, remove the plunger, separate the test pieces and examine them for any damage to the coating in the area of contact; for example, the presence of visible impressions, any sticking of the test pieces, and any detachment of the coating.

8 Expression of results

If desired, the pressure p , in pascals, on the painted surfaces may be calculated from the following equation:

$$p = \frac{m_1 + m_2}{l^2} \times g \times 10^3$$

$$\approx \frac{m_1 + m_2}{l^2} \times 10^4$$

where

- m_1 is the mass, in grams, of the plunger assembly;
- m_2 is the mass, in grams, of the weight;
- l is the width, in millimetres, of the test pieces;
- g is the acceleration of free fall, in newtons per kilogram (approximately 10 N/kg).

9 Precision

No precision data are currently available.

10 Test report

The test report shall contain at least the following information:

- a) all details necessary to identify the product tested;
- b) a reference to this International Standard (ISO 4622);

- c) the items of supplementary information referred to in annex A;
- d) a reference to the international or national standard, product specification or other document supplying the information referred to in c);
- e) the results of the test in terms of the stated requirements and describing any damage (see 7.4 and clause 8);
- f) any deviation from the test method specified;
- g) the date of the test.

iTeh STANDARD PREVIEW
(standards.iteh.ai)

ISO 4622:1992

<https://standards.iteh.ai/catalog/standards/sist/8df7324a-c65b-4e02-b1da-71400d752943/iso-4622-1992>

Annex A (normative)

Required supplementary information

The items of supplementary information listed in this annex shall be supplied as appropriate to enable the method to be carried out.

The information required should preferably be agreed between the interested parties and may be derived, in part or totally, from an international or national standard or other document related to the product under test.

- a) Material (including thickness) and surface preparation of the substrate.
- b) Method of application of the test coating to the substrate, including duration and conditions of drying between coats in the case of a multi-coat system.
- c) Duration and conditions of drying (or stoving) and ageing (if applicable) the coat before testing.
- d) Thickness, in micrometres, of the dry coating and method of measurement in accordance with ISO 2808, and whether it is a single coat or a multi-coat system.
- e) The combined mass of the plunger and weight (i.e. test load) or the pressure to be used.
- f) The time of contact under load of the two pieces.

iTeh STANDARD PREVIEW
(standards.iteh.ai)

[ISO 4622:1992](#)

<https://standards.iteh.ai/catalog/standards/sist/8df7324a-c65b-4e02-b1da-71400d752943/iso-4622-1992>

iTeh STANDARD PREVIEW
(standards.iteh.ai)

ISO 4622:1992

<https://standards.iteh.ai/catalog/standards/sist/8df7324a-c65b-4e02-b1da-71400d752943/iso-4622-1992>

UDC 667.613:620.198

Descriptors: paints, varnishes, tests, stacking tests, compression tests.

Price based on 5 pages
