



Designation: **E3004 – 15^{ε1} E3004 – 20**

Standard Specification for Preparation and Verification of Clay Blocks Used in Ballistic-Resistance Testing of Torso Body Armor¹

This standard is issued under the fixed designation E3004; the number immediately following the designation indicates the year of original adoption or, in the case of revision, the year of last revision. A number in parentheses indicates the year of last reapproval. A superscript epsilon (ϵ) indicates an editorial change since the last revision or reapproval.

^{ε1} NOTE—Editorial corrections made throughout in August 2016.

INTRODUCTION

At the time when work on this specification was undertaken, different ballistic-resistant body armor test protocols required different impactors for verification of the clay blocks placed behind the test items, and the lack of detailed guidance about the clay blocks resulted in different practices for preparation and verification. To improve laboratory-to-laboratory consistency, major stakeholders sought to harmonize practices related to the preparation and verification of the clay blocks used for testing of ballistic-resistant body armor.

1. Scope

1.1 The purpose of this specification is to provide a standardized method for preparation and verification of backing assemblies used in ballistic-resistant torso body armor testing and to reduce variability within and between laboratories.

1.2 The backing assembly is a clay block that contains *ROMA Plastilina No. 1*² clay as the backing material. The clay serves as a witness material and provides a measurable indication of test item performance.

1.3 This specification is primarily directed toward test laboratories but may be applicable to body armor manufacturers, researchers, and end users performing ballistic-resistance testing of body armor.

1.4 *Units*—The values stated in SI units are to be regarded as standard. The values given in parentheses are mathematical conversions to non-SI units that are provided for information only.

1.5 *This standard does not purport to address all of the safety concerns, if any, associated with its use. It is the responsibility of the user of this standard to establish appropriate safety, health, and environmental practices and determine the applicability of regulatory limitations prior to use.*

1.6 *This international standard was developed in accordance with internationally recognized principles on standardization established in the Decision on Principles for the Development of International Standards, Guides and Recommendations issued by the World Trade Organization Technical Barriers to Trade (TBT) Committee.*

2. Referenced Documents

2.1 *ASTM Standards*:³

E3005 Terminology for Body Armor

2.2 *NIST Standard*:⁴

NIST Special Publication 330 The International System of Units (SI), 2008 Edition, Barry N. Taylor and Ambler Thompson, Editors

¹ This specification is under the jurisdiction of ASTM Committee E54 on Homeland Security Applications and is the direct responsibility of Subcommittee E54.04 on Personal Protective Equipment (PPE).

Current edition approved Nov. 1, 2015 April 1, 2020. Published November 2015 April 2020. Originally approved in 2015. Last previous edition approved in 2015 as E3004 – 15^{ε1}. DOI: 10.1520/E3004-15E01-10.1520/E3004-20.

² U.S. Government standards require ROMA Plastilina No. 1[®], from Sculpture House, Inc., as the backing material for ballistic-resistance testing.

³ For referenced ASTM standards, visit the ASTM website, www.astm.org, or contact ASTM Customer Service at service@astm.org. For *Annual Book of ASTM Standards* volume information, refer to the standard's Document Summary page on the ASTM website.

⁴ Available from National Institute of Standards and Technology (NIST), 100 Bureau Dr., Stop 1070, Gaithersburg, MD 20899-1070, http://www.nist.gov.

3. Terminology

3.1 The terms and definitions of Terminology E3005 apply for the following terms: *backing assembly*, *backing fixture*, *backing material*, *bridge gauge*, *clay block*, *clay package*, *clay-verification impactor*, *depth gauge*, *striking device*, and *test item*.

3.2 Definitions of Terms Specific to This Standard:

3.2.1 *backing assembly*, *n*—a backing fixture filled with backing material. For example, a clay block is a type of a backing assembly.

3.2.2 *backing fixture*, *n*—any apparatus designed to hold or contain the backing material(s) for a specific test.

3.2.3 *backing material*, *n*—the substance placed behind the test item during testing which is intended to be a witness material and which may provide a measurable indication of test item performance.

3.2.4 *bridge gauge*, *n*—an assembly used for measuring that consists of a depth gauge and supports that rest on opposite sides of the backing fixture.

3.2.5 *clay block*, *n*—a type of backing assembly in which the backing material is ROMA Plastilina No. 1® modeling clay. See Fig. 1.

3.2.6 *clay package*, *n*—the smallest unit of wrapped and labeled clay as received from the supplier.

3.2.7 *depth gauge*, *n*—instrument (for example, caliper) used to measure the indentations in the backing material caused by the impactor.

3.2.8 *impactor*, *n*—cylindrical device, used during verification of the backing material, having specified dimensions and one hemispherical end.

3.2.9 *striking device*, *n*—a device used on a clay block to establish an appropriate, flat surface on the clay backing material with respect to the backing fixture edges.

3.2.10 *test item*, *n*—a single article intended for testing. Examples may include one panel, one plate, or one shoot pack.

4. Significance and Use

4.1 U.S. Department of Defense and U.S. Department of Justice standards for assessing the performance of ballistic-resistant torso body armor require the use of backing assemblies made with Roma Plastilina No. 1®. It can be demonstrated that the way the clay block is handled prior to and during ballistic testing can have a significant influence on deformation of the clay when a test item is struck by a projectile during testing.

4.2 At the time when work on this specification was undertaken, different ballistic-resistant body armor test protocols required different impactors for verification of the clay blocks placed behind the test items, and the lack of detailed guidance about the clay blocks resulted in different practices for preparation and verification. To improve laboratory-to-laboratory consistency, major stakeholders sought to harmonize practices related to the preparation and verification of the clay blocks used for testing of ballistic-resistant body armor.

5. Equipment

5.1 The equipment used for preparation and verification of clay blocks shall be as described below:

5.1.1 *Backing Fixture*—The backing fixture shall be a rigid, metal frame with a plywood bottom. The inside dimensions of the metal frame shall be 610 ± 2 mm (24.0 ± 0.08 in.) by 610 ± 2 mm (24.0 ± 0.08 in.) with a depth of 140 ± 2 mm (5.5 ± 0.08 in.). The top and bottom edges of the metal frame shall be planar. Plywood, of any grade, that is nominally “ $\frac{3}{4}$ in.” or “18 mm,” shall be attached to the outside of the metal frame to form the bottom of the fixture and shall be removable. See Fig. 21.

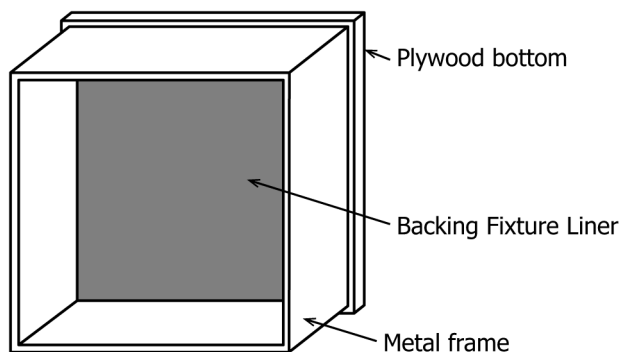

NOTE 1—The plywood bottom is shown larger than the metal frame for illustrative purposes only.

FIG. 21 Backing Fixture

5.1.2 *Backing Fixture Liner*—A liner, such as 0.08 to 0.13 mm (3 to 5 mil) polyethylene sheeting, shall be inserted into the backing fixture to prevent the clay oils from coming into contact with the plywood. The liner shall be placed against the plywood bottom of the backing fixture and shall not extend up the inside surfaces of the metal frame.

NOTE 1—The backing fixture liner is intended to be a barrier between the clay and the plywood and may be sheeting, a coating (for example, spray, paint, shellac), or any other barrier that prevents leaching of oil into the plywood.

5.1.3 *Bridge Gauge*—The bridge gauge shall be a rigid assembly that rests on two parallel strike face edges of the backing fixture and supports a depth gauge that can slide back and forth on the assembly to measure depths across the surface of the backing material. The depth gauge tip that touches the clay shall be hemispherical or spherical with a diameter of 6.35 ± 0.0254 mm (0.25 ± 0.001 in.) and attached to a cylindrical stem having a minimum length of 38.1 mm (1.5 in.) and maximum diameter of 6.35 mm (0.25 in.) such that only the tip touches the deepest location of the indentation. The bridge gauge (independent of the backing fixture) shall have a resolution of 0.01 mm or better with an accuracy of ± 0.1 mm or better.

5.1.4 *Conditioning Chamber*—The chamber shall be temperature controlled, be sufficiently large, and have continuous circulation of air with the intention of uniformly heating all clay blocks in the chamber.

5.1.5 *Impactor:*

5.1.5.1 The impactor shall be a steel, constant diameter cylinder having a hemispherical end of diameter equal to the cylinder diameter and a smooth transition from the hemispherical end to the cylinder body. A drawing specifying the dimensions of the impactor is provided in Fig. 32.

5.1.5.2 The impactor mass shall be 1.0 ± 0.005 kg (2.20 ± 0.01 lb_m).

NOTE 2—To achieve the required mass, the length of the entire impactor will be approximately 90 mm (3.5 in.).

5.1.6 *Striking Device*—The striking device shall be a metal, straight-edged blade capable of spanning two parallel strike face edges of the backing fixture so that the backing fixture serves as the reference for the clay block surface. The striking device shall be sufficiently rigid to facilitate creation of a flat clay surface that is even with the strike face edges of the backing fixture.

5.1.7 *Template*—A circular template shall be used to mark the impact locations on the surface of the clay. The template shall fit within the internal backing fixture dimensions. The impact location centers on the template shown in Fig. 43 are spaced approximately 50 mm (2 in.), 127 mm (5 in.), and 203 mm (8 in.) from the center and approximately 120° apart.

5.1.7.1 The template shall be centered on the clay block, with the template's outer perimeter extending to the inner edge of the backing fixture frame.

5.1.7.2 The purpose of the template is to ensure that the three impact locations meet the drop spacing requirements below:

- (1) Minimum of 76 mm (3.0 in.) from backing fixture edge to nearest indentation edge.
- (2) Minimum of 152 mm (6.0 in.) between impactor indentation centers.

5.1.8 *Test Setup*—The test setup for clay block verification shall consist of a guide tube through which the impactor is dropped (hemispherical end down) onto a clay block that rests on a movable support. See Fig. 54 for an example test setup including guide tube dimensions and spacing between the guide tube and the clay block surface.

5.1.8.1 *Guide Tube*—The guide tube length shall be such that the impactor is within the tube prior to release and entirely out of the tube at impact with the clay block surface. The guide tube length shall be sufficient to minimize yaw of the impactor at the clay surface. The guide tube inside diameter shall be sized to allow the impactor to drop freely and minimize yaw. The guide tube shall be solidly mounted to a fixed surface.

NOTE 3—Holes or slots along the length of the guide tube may be useful to limit effects of air on the impactor as it drops through the tube.

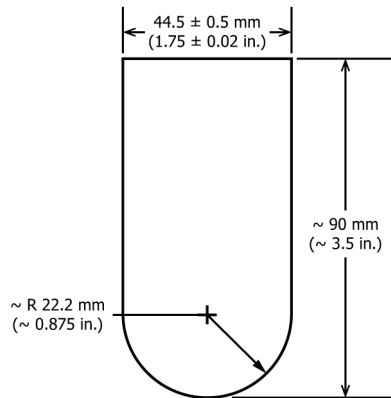

- Notes:
- 1. The material shall be steel with a smooth finish.
 - 2. There shall be a smooth transition from the hemispherical end to the cylindrical body.

FIG. 32 Impactor

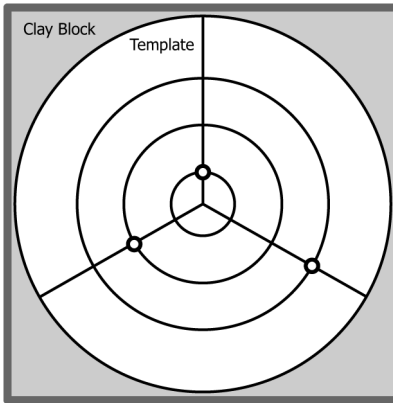

FIG. 43 Template for Impact Locations

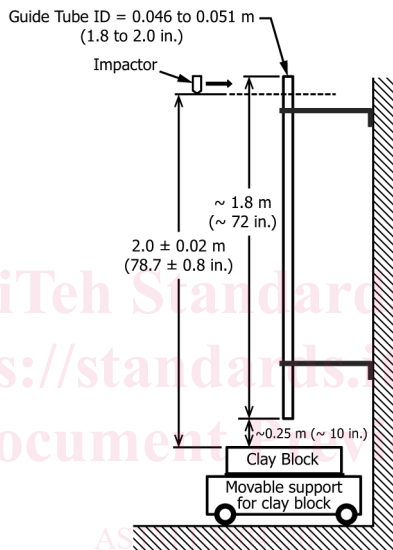

FIG. 54 Example Test Setup

5.1.8.2 *Movable Support*—The support upon which the clay block rests shall allow positioning of the clay block to set the impact locations, keep the clay block level, keep the drop distance constant when the clay block is positioned for different impact locations, and prevent the block from moving vertically due to the impact from the impactor.

5.1.9 *Velocity Measurement Equipment*—The velocity measurement equipment shall be capable of measuring velocities in at least the range of interest with a resolution of 0.005 m/s or better and an accuracy of 0.01 m/s or better. See Appendix X1 for Velocity Measurement Guidance.

6. Procedures

6.1 Characterization of Clay Block Verification Test Setup:

6.1.1 Perform the following steps at installation of a new test setup (see 5.1.8) and periodically thereafter. These steps shall be performed without the clay block or its movable support in the test setup.

6.1.1.1 Verify that the guide tube is straight, plumb, and rigid.

6.1.1.2 Verify that the guide tube is solidly mounted so that it remains in the verified position.

6.1.1.3 To verify the performance of the test setup, the velocity of the impactor at the clay surface is required to be between 6.15 to 6.27 m/s. Perform an appropriate number of impactor drops through the guide tube to determine the drop distance at which a velocity in this range is achieved at the expected point of impact. The drop distance shall be measured from the impactor tip (rounded end) to the expected point of impact.

6.1.1.4 Record the drop distance. The drop distance shall be within 2 ± 0.02 m.

NOTE 4—If the measured drop distance does not meet this requirement, the test setup should be adjusted until the measured velocity and drop distance are within the required ranges.

6.1.2 The value of the measured drop distance shall be used during clay block verifications. The velocity is not required to be measured during actual clay block verifications.