



Designation: **B312—14 B312 – 20**

Standard Test Method for Green Strength of Specimens Compacted from Metal Powders¹

This standard is issued under the fixed designation B312; the number immediately following the designation indicates the year of original adoption or, in the case of revision, the year of last revision. A number in parentheses indicates the year of last reapproval. A superscript epsilon (ϵ) indicates an editorial change since the last revision or reapproval.

1. Scope*

1.1 This standard covers a test method that may be used to measure the transverse rupture strength of a compacted but unsintered (green) test specimen produced from lubricated or unlubricated metal powders or powder mixtures.

1.2 Green strength is measured by a quantitative laboratory procedure in which the fracture strength is calculated from the force required to break an unsintered test specimen supported as a simple beam while subjected to a uniformly increasing three-point transverse load under controlled conditions.

1.3 This test method is a companion standard to Test Method **B528** that covers the measurement of the transverse rupture strength of sintered PM test specimens.

1.4 *Units*—With the exception of the values for density and the mass used to determine density, for which the use of the gram per cubic centimeter (g/cm^3) and gram (g) units is the longstanding industry practice, the values in inch-pound units are to be regarded as standard. The values given in parentheses are mathematical conversions to SI units that are provided for information only and are not considered standard.

1.5 *This standard does not purport to address all of the safety concerns, if any, associated with its use. It is the responsibility of the user of this standard to establish appropriate safety, health, and environmental practices and determine the applicability of regulatory limitations prior to use.*

1.6 *This international standard was developed in accordance with internationally recognized principles on standardization established in the Decision on Principles for the Development of International Standards, Guides and Recommendations issued by the World Trade Organization Technical Barriers to Trade (TBT) Committee.*

2. Referenced Documents

2.1 *ASTM Standards:*²

B215 Practices for Sampling Metal Powders

B243 Terminology of Powder Metallurgy

B528 Test Method for Transverse Rupture Strength of Powder Metallurgy (PM) Specimens

B925 Practices for Production and Preparation of Powder Metallurgy (PM) Test Specimens

B962 Test Methods for Density of Compacted or Sintered Powder Metallurgy (PM) Products Using Archimedes' Principle

E691 Practice for Conducting an Interlaboratory Study to Determine the Precision of a Test Method

3. Terminology

3.1 *Definitions*—The definitions of powder metallurgy (PM) terms used in this test method can be found in Terminology **B243**. Additional descriptive PM information is available in the Related Material section of Vol 02.05 of the *Annual Book of ASTM Standards*.

4. Summary of Test Method

4.1 Three rectangular test specimens are compacted to a predetermined green density or at a specified compacting pressure from test portions of the metal powder or powder mixture that is to be tested.

¹ This test method is under the jurisdiction of ASTM Committee **B09** on Metal Powders and Metal Powder Products and is the direct responsibility of Subcommittee **B09.02** on Base Metal Powders.

Current edition approved ~~June 1, 2014~~ April 1, 2020. Published ~~July 2014~~ April 2020. Originally approved in 1956. Last previous edition approved in ~~2009~~ 2014 as **B312—09**; **B312 – 14**. DOI: ~~10.1520/B0312-14~~ 10.1520/B0312-20.

² For referenced ASTM standards, visit the ASTM website, www.astm.org, or contact ASTM Customer Service at service@astm.org. For *Annual Book of ASTM Standards* volume information, refer to the standard's Document Summary page on the ASTM website.

*A Summary of Changes section appears at the end of this standard

4.2 Each unsintered bar is placed, in turn, in a test fixture and subjected to a uniformly increasing transverse load under controlled conditions until fracture occurs.

4.3 The green strength or maximum flexural stress of each specimen is determined by calculation using the stress equation for a simply supported beam with a concentrated mid-point load.

4.4 The green strength of the material being tested is reported as the arithmetic mean of the results of three individual tests at the measured green density or at the specified compacting pressure rounded to the nearest 100 psi (0.5 MPa).

5. Significance and Use

5.1 The green strength value determined under the conditions specified by this test method is influenced by the characteristics of the powder, how it compacts under the specified conditions (i.e., that is, the particle to particle bonding that exists following compacting), and the lubrication system used.

5.2 Knowledge of the green strength value is useful to the production, characterization, and utilization of metal powders in the manufacture of PM structural parts and bearings.

5.3 The test for green strength of a compacted metal powder can be used to:

5.3.1 Relate the resistance of a pressed compact to breakage or damage due to handling.

5.3.2 Compare the quality of a metal powder or powder mixture from lot to lot.

5.3.3 Determine the effect of the addition of a lubricant or other powders to a base powder.

5.3.4 Evaluate powder mixing or blending variables.

5.4 Factors that are known to influence the green strength of a metal powder are particle shape, particle size distribution, and compressibility of the metal powder.

5.5 The amount and type of lubricant or other additives and the mixing procedures have a strong effect on the green strength of specimens produced from metal powder mixtures.

6. Apparatus

6.1 *Analytical Balance*—A balance readable to 0.001 g with a minimum capacity of 100 g to be used for determining the mass of the test portion of the powder and the green test specimen to the nearest 0.01 g.

6.2 *PM Tool Set*—a compacting die and punches capable of producing the test specimens; specimens, an example of which is shown in Practices B925 as *Laboratory Tooling—Transverse Tooling—Transverse Rupture Test Specimen*.

6.3 *Universal Testing Machine or PM Compacting Press*—a press with the ability to hold the PM tooling and apply the force necessary to compact the test specimens to the target green density.

6.4 *Outside Micrometers or Calipers*—~~instruments~~ Instruments capable of measuring from 0.000 to ~~1.250 in. (31.75 mm)~~ 1.250 in. (0.00 to 31.75 mm) with an accuracy of ~~0.001 in. (0.03 mm)~~ 0.001 in. (0.02 mm).

6.5 Either of the following sets of testing apparatus; apparatus may be used:

6.5.1 *Transverse Rupture Test Fixture and Compression Testing Machine*—a fixture (Fig. 1) for locating the test specimen and a press capable of applying a breaking load at a controlled rate of approximately 20 lbf/min (~90 N/min), and on which the force can be read to the nearest 0.1 lbf (0.5 N), or

6.5.2 *Constant Loading Beam Device, Metal Shot and Scale*—a lever-arm laboratory device (Fig. 2), designed to collect a controlled flow of metal shot that will produce a force with a loading rate of approximately 20 lbf/min (~90 N/min) on a pre-positioned test specimen until fracture occurs, and a scale with a capacity of at least 25 lb (10 kg) to determine the mass to the nearest 0.01 lb (0.005 kg) of the shot that was required.

7. Test Specimen

7.1 The recommended test specimen is an unsintered, (green), rectangular compact having dimensions of ~~0.500 in. (12.70 mm)~~ 0.500 in. (12.70 mm) wide by 1.250 in. (~~31.75 mm~~) (31.75 mm) long as specified in Practices B925 as *Transverse Rupture Strength Test Specimen*.

7.2 Either the *thin* test specimen with a thickness 0.250 ± 0.005 in. (6.35 ± 0.13 mm) or the *thick* test specimen having a thickness of 0.500 ± 0.005 in. (12.70 ± 0.13 mm) may be used as agreed to by the concerned parties.

7.3 The top and bottom faces of the green compact shall be parallel within 0.001 in. (0.03 mm).

7.4 The green density shall be within ± 0.05 – 0.02 g/cm³ of the target green density that has been agreed to between the concerned parties.

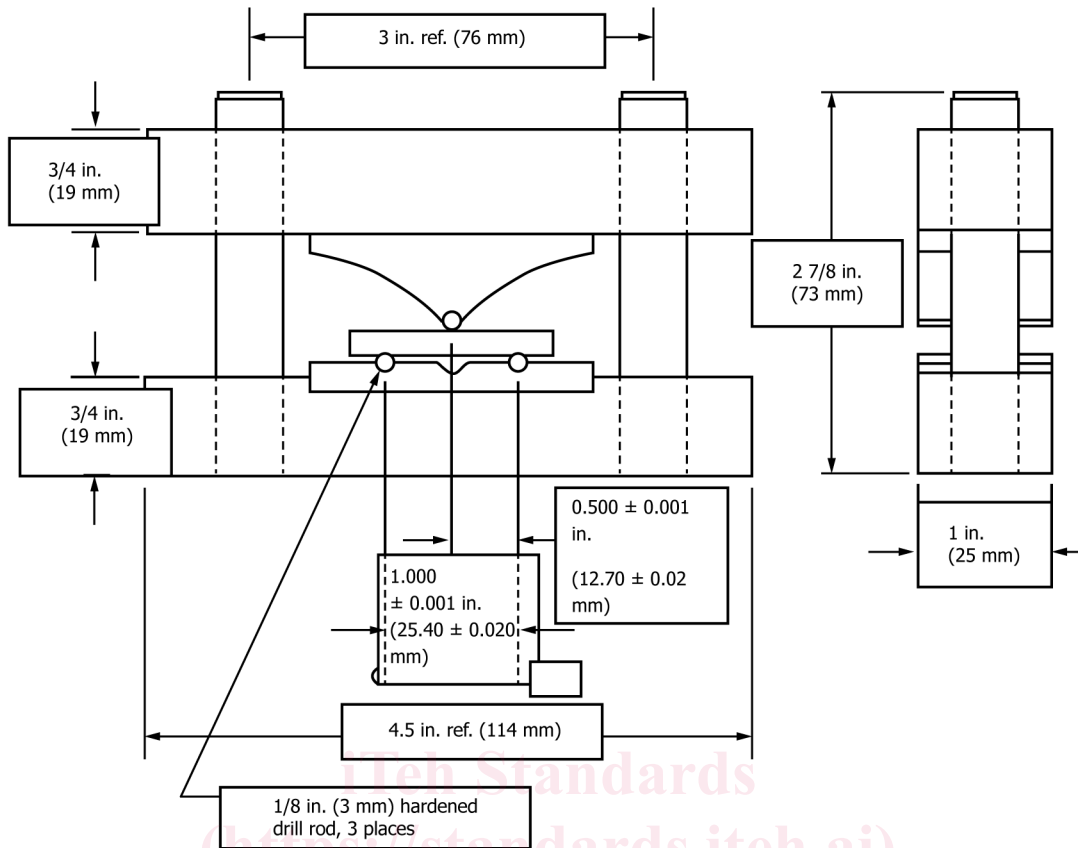

FIG. 1 Transverse Rupture Test Fixture

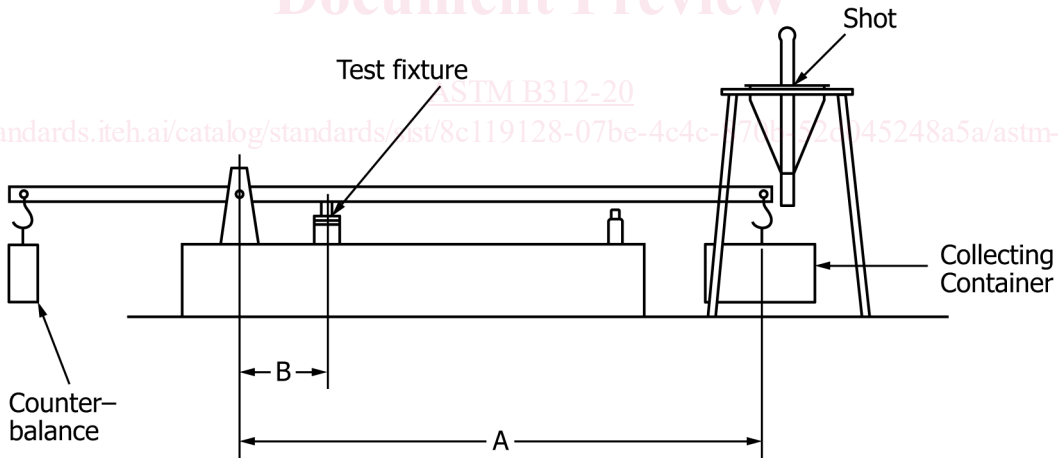

FIG. 2 Example of Constant Loading Beam Device

8. Procedure

8.1 *Lubrication Method*—The lubrication system to be used when compacting the test specimen shall be a matter of agreement between the concerned parties. Compactibility and green density will vary with the method chosen as well as the care with which it is applied and affect the green strength value.

8.1.1 Lubricated metal powder mixtures should be tested in the as-received condition.

8.1.2 Unlubricated metal powder or powder mixtures may be compacted with the aid of die-wall lubrication or an admixed powder lubricant.

8.1.2.1 If die-wall-lubrication is chosen, it shall be applied prior to the compacting of each test specimen following the procedures in Practices B925.