



Designation: ~~D4230 – 02 (Reapproved 2012)~~ D4230 – 20

## Standard Test Method for Measuring Humidity with Cooled-Surface Condensation (Dew-Point) Hygrometer<sup>1</sup>

This standard is issued under the fixed designation D4230; the number immediately following the designation indicates the year of original adoption or, in the case of revision, the year of last revision. A number in parentheses indicates the year of last reapproval. A superscript epsilon ( $\epsilon$ ) indicates an editorial change since the last revision or reapproval.

### 1. Scope

1.1 This test method covers the determination of the thermodynamic dew- or frost-point temperature of ambient air by the condensation of water vapor on a cooled surface. For brevity, this is referred to in this test method as the condensation temperature.

1.2 This test method is applicable for the range of condensation temperatures from 60°C to ~~-70°C~~ to -70°C.

1.3 This test method includes a general description of the instrumentation and operational procedures, including site selection, to be used for obtaining the measurements and a description of the procedures to be used for calculating the results.

1.4 This test method is applicable for the continuous measurement of ambient humidity in the natural atmosphere on a stationary platform.

1.5 The values stated in SI units are to be regarded as standard. No other units of measurement are included in this standard.

1.6 *This standard does not purport to address all of the safety concerns, if any, associated with its use. It is the responsibility of the user of this standard to establish appropriate safety, health, and environmental practices and determine the applicability of regulatory limitations prior to use.* For specific precautionary statements, see Section 8.

1.7 *This international standard was developed in accordance with internationally recognized principles on standardization established in the Decision on Principles for the Development of International Standards, Guides and Recommendations issued by the World Trade Organization Technical Barriers to Trade (TBT) Committee.*

### 2. Referenced Documents

2.1 ASTM Standards:<sup>2</sup>

[D1356 Terminology Relating to Sampling and Analysis of Atmospheres](#)

[D3631 Test Methods for Measuring Surface Atmospheric Pressure](#) ~~0-20~~

### 3. Terminology

3.1 Definitions:

3.1.1 For definitions of other terms in this test method, refer to Terminology [D1356](#).

3.2 Definitions of Terms Specific to This Standard:

3.2.1 *nonhygroscopic material*—~~material~~, *n*—material that neither absorbs nor retains water vapor.

3.2.2 *mirror (front surface)*—~~surface~~, *n*—a polished surface, usually a metallic surface, on which condensates are deposited.

3.3 Symbols:

$e$  = vapor pressure of water vapor in moist air.

$e_i$  = saturation pressure of water vapor in equilibrium with the plane surface of ice.

$e_w$  = saturation pressure of water vapor in equilibrium with the plane surface of water.

$P$  = ambient pressure.

$r$  = mixing ratio.

$T$  = ambient air temperature.

$T_d$  = thermodynamic dew- or frost-point temperature.

<sup>1</sup> This test method is under the jurisdiction of ASTM Committee D22 on Air Quality and is the direct responsibility of Subcommittee D22.11 on Meteorology.

Current edition approved April 1, 2012; March 1, 2020. Published July 2012; April 2020. Originally approved in 1983. Last previous edition approved in 2007; 2012 as D4230 – 02 (2007); (2012). DOI: ~~10.1520/D4230-02R12~~ 10.1520/D4230-20.

<sup>2</sup> For referenced ASTM standards, visit the ASTM website, www.astm.org, or contact ASTM Customer Service at service@astm.org. For Annual Book of ASTM Standards volume information, refer to the standard's Document Summary page on the ASTM website.

$RH_i$  = relative humidity with respect to ice.  
 $RH_w$  = relative humidity with respect to water.

#### 4. Summary of Test Method

- 4.1 The ambient humidity is measured with a dew- and frost-point hygrometer.
- 4.2 The mirror or some other surface on which the condensate is deposited is provided with the means for cooling and heating, detection of condensate, and the measurement of the temperature of the mirror surface.
- 4.3 Calculations of saturation vapor pressure over water and ice as functions of temperature are provided.

#### 5. Significance and Use

5.1 Humidity information is important for the understanding of atmospheric phenomena and industrial processes. Measurements of the dew-point and calculations of related vapor pressures are important to quantify the humidity information.

#### 6. Interferences

- 6.1 This test method is not applicable if other constituents in the atmosphere condense before water vapor.

#### 7. Apparatus

7.1 *Dew-point hygrometers*, specifically designed for meteorological observations are available commercially. A schematic arrangement of a typical optical dew-point hygrometer is shown in Fig. 1.

- 7.1.1 The sample air flows through a small chamber.
- 7.1.2 Within the chamber is a mirror or surface on which the condensate can be deposited.
- 7.1.3 A beam of light from an incandescent lamp, light emitting diode or other suitable light source shines on the mirror.
- 7.1.4 Dew or frost is detected with an electro-optic device.
- 7.1.5 The mirror is cooled by a Peltier thermoelectric element. Peltier cooling is a convenient method for unattended and automatic instruments.
- 7.1.6 Preferred devices of sensing mirror temperature are resistance thermometers, thermistors, and thermocouples.
- 7.1.6.1 The temperature sensors shall be attached to or embedded in the mirror to measure the temperature of the surface of the mirror.
- 7.1.7 Suitable control circuitry shall be provided to maintain a constant quantity of condensate on the mirror.
- 7.1.8 Suitable provisions shall be provided to compensate for the contamination of the surface of the mirror.

ASTM D4230-20

<https://standards.iteh.ai/catalog/standards/sist/2e4e57aa-f729-4e26-b9a9-b256ac1c7b1a/astm-d4230-20>

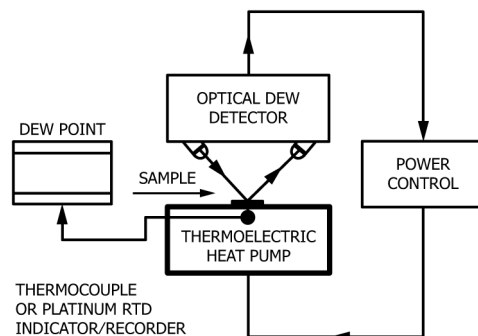

FIG. 1 Schematic of a Thermolectric Cooled Condensation Hygrometer

## 7.2 Auxiliary Equipment:

7.2.1 Provision shall be provided for assuring air flow past the dewpoint mirror without changing the pressure in the mirror chamber more than 0.5 % from the ambient pressure surrounding the sensor. An air flow of approximately 1.1 litres per minute is recommended for typical chambers.

7.2.2 Readout instrumentation is available with the dew-point hygrometer.

## 8. Precautions

### 8.1 Safety Precautions:

8.1.1 The hygrometer shall be packaged in a suitable enclosure for application in industrial or outdoor environment.

8.1.2 Electrical connectors and cables shall be suitable for the industrial or outdoor environment.

8.1.3 Appropriate voltage surge protection circuitry must be incorporated.

### 8.2 Technical Precautions:

8.2.1 The accuracy of a cooled-surface condensation hygrometer is degraded by the presence of water-soluble materials. A mirror-cleaning schedule, consistent with the contamination rate, is necessary to maintain the initial calibration accuracy. The user must determine the required maintenance schedule for the specific site, by comparison of calibrations made before and after cleaning.

8.2.2 Caution in performing this test method should be taken if the indicated mirror temperature is between 0°C and ~~-30°C~~ and ~~-30°C~~. Below freezing, the initial formation of the condensate on the surface of a mirror may be either dew or frost. In the case of nonfiltered atmospheric air, the supercooled water usually does not persist long on a mirror surface and quickly changes to frost. The only positive method for determining the state of the condensate is by visual observation of the mirror surface.

8.2.2.1 The following illustrates the magnitude of the error involved when dew or frost is not differentiated: The saturation vapor pressure of supercooled water at ~~-30°C~~ at ~~-30°C~~ corresponds to saturation vapor pressure of ice at ~~-27.2°C~~; at ~~-27.2°C~~; dew point of ~~-20°C~~ of ~~-20°C~~ corresponds to frost point of ~~-18.0°C~~; ~~-10°C~~ of ~~-18.0°C~~; ~~-10°C~~ dew point corresponds to frost point of ~~-8.9°C~~; of ~~-8.9°C~~. (The frost point temperature is approximately 90 % of the dew-point temperature in degrees Celsius.)

8.2.3 A positive method for identifying the state of the condensate is to visually observe the condensate on the mirror with the aid of a microscope or other optical magnifier.

8.2.4 A finite length of time is required for the condensate to deposit on the mirror and for the hygrometer to reach equilibrium with the ambient humidity. The response of the hygrometer depends on the humidity of the ambient air, and on such factors as the ventilation rate of the ambient air past the mirror, the sensitivity of the condensate detector, and the maximum cooling rate of the hygrometer. The worst case occurs during the initial dew-point reading after clearing the mirror of all condensates. The time it takes the hygrometer to reach equilibrium after clearing the mirror will vary from instrument to instrument. As an illustration of the magnitude of this time, the following are approximate times required by a hygrometer to reach equilibrium after clearing the mirror.

8.2.4.1 For dew points warmer than 0°C: 5 min after clearing.

8.2.4.2 For dew points 0°C to ~~-20°C~~; to ~~-20°C~~: 5 to 20 min after clearing.

8.2.4.3 For dew points ~~-20°C~~ to ~~-40°C~~; points ~~-20°C~~ to ~~-40°C~~: 20 min to 1 h after clearing.

8.2.4.4 For dew points ~~-40°C~~ to ~~-60°C~~; points ~~-40°C~~ to ~~-60°C~~: 1 h to 2 h after clearing.

8.2.4.5 For dew points ~~-60°C~~ to ~~-70°C~~; points ~~-60°C~~ to ~~-70°C~~: 2 h to 6 h after clearing.

8.2.5 The pressure differential between the mirror chamber and the ambient shall not be greater than 0.5 % of the ambient pressure. For example, the difference shall not exceed 5 hPa at an ambient pressure of 1000 hPa.

NOTE 1—The hectopascal (hPa) is equivalent to the millibar (1).<sup>3</sup>

8.2.6 The thermometer must measure the temperature of the mirror surface and not be influenced by the ambient air temperature.

8.2.7 All materials, which come into contact with the sample air before it reaches the dew-point mirror, shall be nonhygroscopic. Metal, glass, polytetrafluoroethylene, or stabilized polypropylene are examples of suitable materials. Polyvinyl chloride tubing must be avoided.

## 9. Sampling

9.1 Automatic dew-point hygrometers provide an output which may be recorded continuously. Modern data loggers sample temperature-sensor output periodically, convert the analog sensor signal to a digital form, and store the data. The proper sampling interval depends on the data application (see 13.2).

9.2 Locate a blower or pump, which can be used to move the air sample through the mirror chamber, downstream of the dew-point mirror. The airflow rate also depends on the data application and sampling environment.

9.3 Select the site or location so that the measurement data represents the water vapor content of the ambient atmosphere or industrial environment being sampled. Local water vapor sources, including ponds, wet roads, and structures can influence the ambient humidity. Avoid sources of airborne contaminants that can influence to condensation process on the mirror.

<sup>3</sup> The boldface numbers in parentheses refer to ~~the a list of~~ references at the end of this ~~method standard~~.

9.4 The successful application of this test method requires that all the materials which come in contact with the sample air upstream of the dew-point mirror be nonhygroscopic.

9.5 The materials which come in contact with the sample air upstream of the dew-point mirror might be wetted by rain, dew, or frost; for example, dew forming on a surface in the early morning. Design the sampling system to minimize these deleterious effects.

## 10. Calibration

10.1 Provide the calibration data for the thermometer, used for measuring the condensation temperature with the hygrometer. Consult the manufacturer's operating manual for calibrating the thermometer readout instrumentation.

10.2 The cooled-surface condensation (dew-point) method is considered to be an absolute or fundamental method for measuring humidity. This test method requires an accurate measurement of the temperature of the surface of the dew-point mirror. It is not uncommon for the dew-point temperature to be more than  $35^{\circ}\text{C}$  ~~35~~<sup>35</sup> $^{\circ}\text{C}$  colder than the ambient air temperature. To measure this temperature accurately, without being influenced by the warmer ambient and the colder heat-sink temperature, requires careful placement of the dew-point thermometer.

10.3 Therefore, in addition to the temperature calibration of the ~~thermometer,~~ thermometer (see 10.1), a humidity calibration must also be performed to verify the proper operation of the hygrometer (see [Annex A1](#)). The following are additional examples of factors that can affect the accuracy of the measurement: extraneous thermally-induced voltage (emf), heat leakage through the thermometer leads, self-heating of the thermometer, poor thermal contact, temperature gradient across the mirror, etc.

## 11. Procedure

11.1 *Selection of Sampling Site*—Select sampling site as indicated in 9.3 and also in ~~4.3.21.3.3~~ of the World Meteorological Organization, *Guide to Meteorological Instrument and Observing Practices* (12).

11.2 Consult the manufacturer's operating manual for start-up procedures.

11.3 Perform necessary calibration as indicated in Section 10. The dew-point thermometer will not undergo large shifts ( $0.05^{\circ}\text{C}$ ) in calibration unless it is subjected to physical shock. If the thermometer read-out instrumentation is subjected to varying ambient temperatures, the read-out instrumentation checks must be over the expected range of ambient temperatures. The frequency with which these checks are required will be determined by the stability of the readout instrumentation.

11.4 Check and verify that all necessary variables are measured and recorded to compute the humidity in the desired ~~unit(s)~~unit(s); see also [Section 12](#).

NOTE 2—In general, it is recommended that ambient temperature and pressure (the pressure in the mirror chamber should not differ from the ambient pressure by more than 0.5 %) and the dew-point temperature be measured and recorded. The ambient pressure is to be measured according to Test Methods [D3631](#). This will enable other users of the data to calculate in the different units of humidity.

## 12. Calculations

12.1 In the meteorological range of pressure and temperature, the saturation vapor pressure of the pure water phase and of the moist air will be assumed to be equal. This assumption will introduce an error of approximately 0.5 % of reading or less.

12.2 Calculate the ambient relative humidity with respect to water using the following approximation.

$$(RH_w)_T = \frac{e(T_d)}{e_w(T)} 100\% \quad (1)$$

where:

$(RH_w)_T$  = relative humidity with respect to water, %, at temperature  $T$  ( $^{\circ}\text{C}$ ),

$e(T_d)$  = saturation vapor pressure, Pa, at condensation temperature  $T_d$ ,  $^{\circ}\text{C}$ , where  $T_d$  is the average value during the sampling period, see [Note 2](#), and

$e(T_d)$  = saturation vapor pressure, Pa, at condensation temperature  $T_d$ ,  $^{\circ}\text{C}$ , where  $T_d$  is the average value during the sampling period, see [Note 3](#), and

$e_w(T)$  = saturation vapor pressure, Pa, over water at ambient temperature  $T$ ,  $^{\circ}\text{C}$ , where  $T$  is the average value during the sampling period.

NOTE 3—If the condensate on the mirror is water (dew), use the saturation vapor pressure over water corresponding to the condensation temperature  $T_d$ . If the condensate is ice (frost), use the saturation vapor pressure over ice corresponding to the condensation temperature  $T_d$ . Equations for saturation vapor pressure are provided in [12.5](#).

12.3 Calculate the relative humidity with respect to ice as follows:

$$(RH_i)_T = \frac{e(T_d)}{e_i(T)} 100\% \quad (2)$$