



Designation: **C131/C131M—14** **C131/C131M—20**

## Standard Test Method for Resistance to Degradation of Small-Size Coarse Aggregate by Abrasion and Impact in the Los Angeles Machine<sup>1</sup>

This standard is issued under the fixed designation C131/C131M; the number immediately following the designation indicates the year of original adoption or, in the case of revision, the year of last revision. A number in parentheses indicates the year of last reappraisal. A superscript epsilon ( $\epsilon$ ) indicates an editorial change since the last revision or reappraisal.

*This standard has been approved for use by agencies of the U.S. Department of Defense.*

### 1. Scope\*

1.1 This test method covers a procedure for testing of coarse aggregates with a maximum size smaller than 37.5 mm ([1½ in.] for resistance to degradation using the Los Angeles testing machine (**Note 1**).

NOTE 1—A procedure for testing coarse aggregate larger than 19.0 mm [ $\frac{3}{4}$  in.] is covered in Test Method **C535**. Thus coarse aggregates with a maximum size between 19 mm [ $\frac{3}{4}$  in.] and 37.5 mm [1½ in.] may be tested by Test Method **C535** or Test Method C131/C131M.

1.2 The values stated in either SI units or inch-pound units are to be regarded separately as standard. The values stated in each system are not necessarily exact equivalents; therefore, to ensure conformance with the standard, each system shall be used independently of the other, and values from the two systems shall not be combined.

NOTE 2—Sieve size is identified by its standard designation in Specification **E11**. The Alternative designation given in parentheses is for information only and does not represent a different standard sieve size.

1.3 *This standard does not purport to address all of the safety concerns, if any, associated with its use. It is the responsibility of the user of this standard to establish appropriate safety, health, and environmental practices and determine the applicability of regulatory limitations prior to use.*

1.4 *This international standard was developed in accordance with internationally recognized principles on standardization established in the Decision on Principles for the Development of International Standards, Guides and Recommendations issued by the World Trade Organization Technical Barriers to Trade (TBT) Committee.*

### 2. Referenced Documents

2.1 *ASTM Standards:*<sup>2</sup>

**A6/A6M** Specification for General Requirements for Rolled Structural Steel Bars, Plates, Shapes, and Sheet Piling

**C125** Terminology Relating to Concrete and Concrete Aggregates

**C136** Test Method for Sieve Analysis of Fine and Coarse Aggregates

**C535** Test Method for Resistance to Degradation of Large-Size Coarse Aggregate by Abrasion and Impact in the Los Angeles Machine

**C670** Practice for Preparing Precision and Bias Statements for Test Methods for Construction Materials

**C702** Practice for Reducing Samples of Aggregate to Testing Size

**D75** Practice for Sampling Aggregates

**E11** Specification for Woven Wire Test Sieve Cloth and Test Sieves

### 3. Terminology

3.1 *Definitions*—For definitions of terms used in this test method, refer to Terminology **C125**.

### 4. Summary of Test Method

4.1 This test is a measure of degradation of mineral aggregates of standard gradings resulting from a combination of actions including abrasion or attrition, impact, and grinding in a rotating steel drum containing a specified number of steel spheres, the

<sup>1</sup> This test method is under the jurisdiction of ASTM Committee **C09** on Concrete and Concrete Aggregates and is the direct responsibility of Subcommittee **C09.20** on Normal Weight Aggregates.

Current edition approved July 1, 2014; Feb. 15, 2020. Published July 2014; April 2020. Originally approved in 1937. Last previous edition approved in 2006/2014 as **C131/C131M—14**. —06—DOI: 10.1520/C0131-C0131M-14; 10.1520/C0131-C0131M-20.

<sup>2</sup> For referenced ASTM standards, visit the ASTM website, www.astm.org, or contact ASTM Customer Service at service@astm.org. For *Annual Book of ASTM Standards* volume information, refer to the standard's Document Summary page on the ASTM website.

\*A Summary of Changes section appears at the end of this standard

number depending upon the grading of the test sample. As the drum rotates, a shelf plate picks up the sample and the steel spheres, carrying them around until they are dropped to the opposite side of the drum, creating an impact-crushing effect. The contents then roll within the drum with an abrading and grinding action until the shelf plate picks up the sample and the steel spheres, and the cycle is repeated. After the prescribed number of revolutions, the contents are removed from the drum and the aggregate portion is sieved to measure the degradation as percent loss.

**5. Significance and Use**

5.1 This test has been widely used as an indicator of the relative quality or competence of various sources of aggregate having similar mineral compositions. The results do not automatically permit valid comparisons to be made between sources distinctly different in origin, composition, or structure. Assign specification limits with extreme care in consideration of available aggregate types and their performance history in specific end uses. The percent loss determined by this test method has no known consistent relationship to the percent loss for the same material when tested by Test Method C535.

**6. Apparatus**

6.1 *Los Angeles Machine*—A Los Angeles machine, conforming in all essential characteristics to the design shown in Fig. 1, shall be used. The machine shall consist of a hollow steel cylinder, with a wall thickness of at least 12 mm [ $\frac{1}{2}$  in.] (Note 3) closed at both ends, conforming to the dimensions shown in Fig. 1, having an inside diameter of  $711 \pm 5$  mm [ $28 \pm 0.2$  in.], and an inside length of  $508 \pm 5$  mm [ $20 \pm 0.2$  in.]. The interior surface of the cylinder shall be free from protrusions disrupting the path of the sample and steel spheres except for the shelf described below. The cylinder shall be mounted on stub shafts attached to the ends of the cylinder but not entering it, and shall be mounted in such a manner that it rotates with the axis

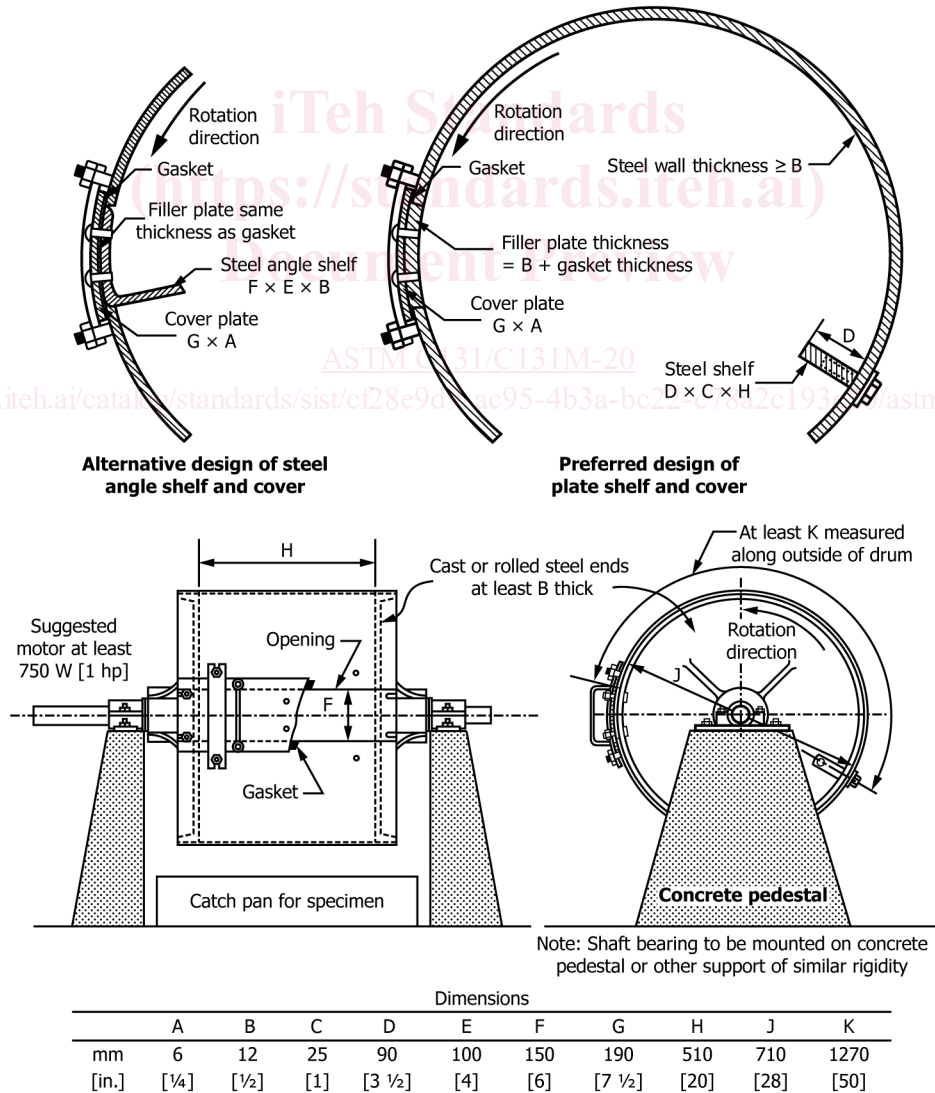

**FIG. 1 Los Angeles Testing Machine**