



Standard Test Methods for Fire Resistive Grease Duct Enclosure Systems¹

This standard is issued under the fixed designation E2336; the number immediately following the designation indicates the year of original adoption or, in the case of revision, the year of last revision. A number in parentheses indicates the year of last reapproval. A superscript epsilon (ϵ) indicates an editorial change since the last revision or reapproval.

INTRODUCTION

The protection of grease ducts under fire exposure conditions is an item of importance in securing constructions that are safe, and that are not a menace to neighboring construction nor to the public. Recognition of this is registered in the codes of many authorities, municipal and other agencies. Many types of enclosure materials are used to protect grease ducts. Normally, these enclosure materials are either applied to grease ducts in the field or are fabricated as part of the grease duct when shipped from the factory. Evaluating enclosure materials used to protect a grease duct from fire is an aid for predicting their fire performance and promotes uniformity in requirements of various authorities. To do this it is necessary that the fire-endurance properties of enclosure materials be measured and specified according to a common standard expressed in terms that are applicable alike to a wide variety of materials, situations, and conditions of exposure.

1. Scope*

NOTE 1—The majority of this standard is based on the Model Building Code Evaluation Service² Acceptance Criteria titled *ACCEPTANCE CRITERIA FOR GREASE DUCT ENCLOSURE ASSEMBLIES, AC101*, which was created in 1994. Numerous design listings and labeled materials exist based on the provisions of this standard.

1.1 These test methods evaluate the enclosure materials and the grease duct enclosure systems using the following test methods: noncombustibility, fire resistance, durability, internal fire, and fire-engulfment with a through-penetration fire stop.

1.2 These test methods prescribe a standardized fire exposure for comparing the test results of the enclosure materials and grease duct enclosure systems. The results of these tests are one factor in assessing predicted fire performance of grease duct enclosure systems. Using these test results to predict the performance of actual grease duct enclosure systems requires the evaluation of test conditions.

1.3 The values stated in inch-pound units are to be regarded as standard. The values given in parentheses are mathematical conversions to SI units that are provided for information only and are not considered standard.

1.4 The text of these test methods references notes and footnotes which provide explanatory material. These notes and

footnotes (excluding those in tables and figures) shall not be considered as requirements of the fire test response standard.

1.5 *These test methods are used to measure and describe the response of materials, products, or assemblies to heat and flame under controlled conditions, but does not by itself incorporate all factors required for fire hazard or fire risk assessment of the materials, products, or assemblies under actual fire conditions.*

1.6 *These test methods do not purport to address all of the safety concerns, if any, associated with its use. It is the responsibility of the user of these test methods to establish appropriate safety and health practices and to determine the applicability of regulatory limitations prior to use.*

1.7 *This international standard was developed in accordance with internationally recognized principles on standardization established in the Decision on Principles for the Development of International Standards, Guides and Recommendations issued by the World Trade Organization Technical Barriers to Trade (TBT) Committee.*

2. Referenced Documents

2.1 ASTM Standards:³

- C518 Test Method for Steady-State Thermal Transmission Properties by Means of the Heat Flow Meter Apparatus
- C569 Test Method for Indentation Hardness of Preformed

¹ This test method is under the jurisdiction of ASTM Committee E05 on Fire Standards and is the direct responsibility of Subcommittee E05.11 on Fire Resistance.

Current edition approved April 1, 2020. Published April 2020. Originally approved in 2004. Last previous edition approved in 2016 as E2336–16. DOI: 10.1520/E2336-20.

² ICC Evaluation Service, Inc. (ICBO Evaluation Service, Inc.) 5360 Workman Mill Road, Whittier, CA 90601-2298

³ For referenced ASTM standards, visit the ASTM website, www.astm.org, or contact ASTM Customer Service at service@astm.org. For *Annual Book of ASTM Standards* volume information, refer to the standard's Document Summary page on the ASTM website.

*A Summary of Changes section appears at the end of this standard

- Thermal Insulations (Withdrawn 1988)⁴
- E84** Test Method for Surface Burning Characteristics of Building Materials
- E119** Test Methods for Fire Tests of Building Construction and Materials
- E136** Test Method for Assessing Combustibility of Materials Using a Vertical Tube Furnace at 750°C
- E176** Terminology of Fire Standards
- E631** Terminology of Building Constructions
- E814** Test Method for Fire Tests of Penetration Firestop Systems
- 2.2 *Other Documents:*
- UL 385** Standard for Play Pipes for Water Supply Testing in Fire-Protection Service⁵

3. Terminology

3.1 *Definitions:* For definitions of terms used in this test method associated with fire issues refer to the definitions contained in Terminology **E176** and for building issues refer to the definitions contained in Terminology **E631**. When there is a conflict between Terminology **E176** and Terminology **E631** definitions, the definitions in Terminology **E176** shall apply.

3.2 *Definitions of Terms Specific to This Standard:*

3.2.1 *enclosure material, n*—the product applied to the grease duct to provide fire resistance.

3.2.2 *fire-separating element, n*—floors, walls, and partitions having a period of fire resistance determined in accordance with fire resistance test methods such as Test Methods **E119**.

3.2.3 *fire side, adj*—the face of the test assembly or test specimen exposed to the heat or flame or both of the test apparatus.

3.2.4 *grease duct (also known as kitchen exhaust grease duct), n*—a tube or conduit utilized for conveying air.

3.2.4.1 *Discussion*—It is usually equipped with an access opening for cleaning the orifice.

3.2.5 *grease duct enclosure system, n*—consists of the grease duct, an enclosure material(s), a support and fastening system, and an access opening for cleaning the grease duct.

3.2.6 *orifice, n*—the continuous hollow area or opening within the grease duct or combustion chamber.

3.2.7 *supporting construction, n*—the arrangement of building sections forming the fire-separating elements into which the grease duct enclosure system is installed.

3.2.8 *test assembly, n*—the complete assembly composed of a test specimen(s) together with its supporting construction.

3.2.9 *test specimen, n*—a material, product, or assemblage of a specific design, composition, density, and dimensions.

3.2.9.1 *Discussion*—the enclosure material or the grease duct enclosure system are examples of test specimens.

3.2.10 *unexposed side, n*—the face or part not directly exposed to the heat or flame or both of the test apparatus.

⁴ The last approved version of this historical standard is referenced on www.astm.org.

⁵ Available from Underwriters Laboratories (UL), Corporate Progress, 333 Pfingsten Rd., Northbrook, IL 60062.

3.2.11 *unexposed surface thermocouple, n*—temperature-measuring device placed on the unexposed side.

4. Summary of Test Method

4.1 Representative test specimens of the enclosure material or the grease duct enclosure system are subjected to the following tests. These test methods describe the following test sequence and procedures:

4.1.1 A noncombustibility test, Test Method **E136**, demonstrates the enclosure material's ability to resist combustion at a standardized temperature and duration.

4.1.2 A durability test intended to simulate the effects of long-term exposure of typical in-service conditions on the thermal transmission qualities of the enclosure materials when subjected to a modified version of Test Method **C518**.

4.1.3 An internal fire test uses two standardized fire exposures occurring inside the grease duct. Both tests illustrate the enclosure material's ability to resist thermal transmission of heat to the unexposed side in a horizontal application. The first standardized fire exposure is intended to simulate long term exposure of the enclosure material to a standardized service condition. The second standardized fire exposure is intended to simulate a standardized grease fire.

4.1.4 A fire-engulfment test uses a standardized fire exposure, the time temperature curve of Test Methods **E119**, to simulate a fire occurring on the outside of the grease duct, and demonstrates the ability of the grease duct enclosure system to remain intact without a through opening. The fire-engulfment test also tests the fastening methods used to secure the enclosure material to the grease duct and the supporting system. The fire-engulfment test also provides a means to test a through-penetration fire stop to determine its compatibility with the grease duct enclosure system.

5. Significance and Use

5.1 These test methods are intended to evaluate the ability of the grease duct enclosure system to do the following:

5.1.1 Resist the effects of a standardized fire exposure,

5.1.2 Retain its integrity, or

5.1.3 Exhibit both properties dependent upon the type of test assembly involved during a predetermined test exposure.

5.2 These test methods provide for the following measurements and evaluations where applicable:

5.2.1 Capability of the enclosure material to resist flaming (combustion) when exposed to 1382°F (750°C).

5.2.2 Loadbearing ability of the tested support system and fastening system to carry the load of the grease duct enclosure system during a standardized fire-engulfment test.

5.2.3 Ability of a fire stop to meet the requirements of Test Method **E814** when used with a grease duct enclosure system.

5.2.4 Ability of the enclosure material to resist the passage of flames and hot gases during a standardized fire resistance test and a standardized internal fire test.

5.2.5 Transmission of heat through the grease duct and the enclosure material(s) during a standardized fire resistance test and a standardized internal fire test.

5.2.6 Ability of the grease duct enclosure system to resist the passage of water during a standardized hose stream test.

5.2.7 Comparative measurement of temperature aging of the enclosure material(s) when subjected to standardized cyclic thermal transmissions.

5.3 These test methods do not provide the following:

5.3.1 Full information as to performance of the enclosure material or the grease duct enclosure system constructed with components, densities, or dimensions other than those tested.

5.3.2 Evaluation of the degree by which the enclosure material or grease duct enclosure system contributes to the fire hazard by generation of smoke, toxic gases, or other products of combustion.

5.3.3 Measurement of the degree of control or limitation of the passage of smoke or products of combustion through the grease duct enclosure system.

5.3.4 Measurement of flame spread over the surface of the grease duct enclosure system.

NOTE 2—The information in 5.3.2 – 5.3.4 is usually determined by other suitable test methods. For example, 5.3.4 is typically determined using Test Method E84.

5.4 In these test methods, the test specimens are subjected to one or more specific tests under laboratory conditions. When different test conditions are substituted or the end-use conditions are changed, it is not always possible by, or from, these test methods to predict changes to the characteristics measured. Therefore, the results of these laboratory tests are valid only for the exposure conditions described in these test methods.

5.5 Various test methods in these test methods require a test specimen to be exposed to a standard fire that is controlled to achieve specified temperatures throughout a specified time period. The fire-engulfment and vertical fire resistance tests are followed by the application of a standardized hose stream test. These test methods provide a relative measure of the fire-test-response of comparable enclosure materials and grease duct enclosure systems under these exposure conditions. The fire exposure is not representative of all fire conditions because conditions vary with changes in the amount, nature and distribution of fire loading, ventilation, compartment size and configuration, and heat sink characteristics of the compartment. Variation from the test conditions or test specimen construction, such as size, materials, method of assembly, also affects the fire-test-response. For these reasons, evaluation of the variation is required for application to construction in the field.

6. Apparatus

6.1 *Combustion Chamber*—A tubular L-shaped assembly used with a gas-fired burner(s) capable of delivering the minimum interior temperatures for the internal fire test as specified in Section 13.

NOTE 3—An example of such a device is an L-shaped square steel tube measuring 84 ± 1 in. by 96 ± 1 in. on the exterior legs with an orifice measuring a minimum 24 by 24 in. and insulated on the interior with a minimum 2 in. thick 8 lb/ft³ density ceramic fiber blanket as shown in Fig. 1.

6.2 *Gas-fired Burner*—A device that produces heat and flame from a gas undergoing combustion that is capable of

providing the minimum temperatures to perform the internal fire test as specified in Section 13.

NOTE 4—A burner with a minimum heat input (Btu/h) of at least 925 times the cross-sectional area of the test assembly orifice, in.² (mm²), has been proven adequate to produce the 500°F (260°C) internal temperature during that exposure period and a burner with a minimum heat input (Btu/h) of at least 4025 times the cross-sectional area of the test assembly orifice, in.² (mm²), has been proven adequate to produce the 2000°F (1093°C) internal temperature during that exposure period. For rectangular ducts, the cross-sectional area shall be modified when determining the minimum heat input. For rectangular ducts, an equivalent diameter (DE) and the equivalent cross-sectional area shall be determined as follows:

$$D_E = 1.30(ab)^{0.625}/(a + b)^{0.25} \quad (1)$$

where:

a = length of one side of duct,
 b = length of adjacent side of duct, and
*Equivalent Area*⁶ = $(D_E/2)^2$

6.3 *Furnace*—An enclosed furnace facility capable of controlling a fire to the time-temperature curve in Test Methods E119. A horizontal furnace is shown in Fig. 2.

6.4 *Furnace Thermocouples*:

6.4.1 The E119 furnace thermocouples shall:

6.4.1.1 Be protected by sealed porcelain tubes having a nominal 3/4-in. (19-mm) outside diameter and 1/8-in. (3-mm) wall thickness, or, as an alternative, in the case of base metal thermocouples, protected by a standard 1/2-in. (13-mm) diameter wrought steel or wrought iron pipe of standard weight, and

6.4.1.2 Have a time constant between the range of 5.0 to 7.2 min while encased in the tubes described in 6.4.1.1.

6.4.2 Other types of E119 protection tubes or pyrometers shall be used only when they give the same indications under test conditions as those of 6.4.1.2 within the limit of accuracy that applies for furnace-temperature measurements.

NOTE 5—A typical thermocouple assembly meeting these time constant requirements is fabricated by fusion-welding the twisted ends of No. 18 gage Chromel-Alumel wires, mounting the leads in porcelain insulators and inserting the assembly so the thermocouple bead is approximately 0.5 in. (25 mm) from the sealed end of the standard weight nominal 1/2-in. (25-mm) iron, steel, or Inconel⁷ pipe. The time constant for this and for several other thermocouple assemblies was measured in 1976. Another option is to calculate the time constant from knowledge of its physical and thermal properties.⁸

6.5 *Pressure-sensing Probes*—Where applicable, tolerances are $\pm 5\%$ of dimensions shown in Fig. 3 or Fig. 4.

6.5.1 The pressure-sensing probes shall be either a T-shaped sensor as shown in Fig. 3, or a tube sensor as shown in Fig. 4

6.6 *Unexposed Surface Thermocouples*:

6.6.1 The unexposed surface thermocouple wires, which shall be covered by the thermocouple pads described in 6.7 during testing, shall not be heavier than No. 18 B and S gage (0.040 in.) (1.02 mm), and shall be electrically insulated with heat-resistant and moisture-resistant coatings.

6.7 *Thermocouple Pads*:

⁶ ASHRAE Fundamentals Handbook, Chapter 32: Duct Design.

⁷ Inconel is a registered trade name of INCO Alloys, Inc., 3800 Riverside Dr., Huntington, WV 25720.

⁸ Supporting data is available from ASTM International Headquarters. Request RR:E05-1001.

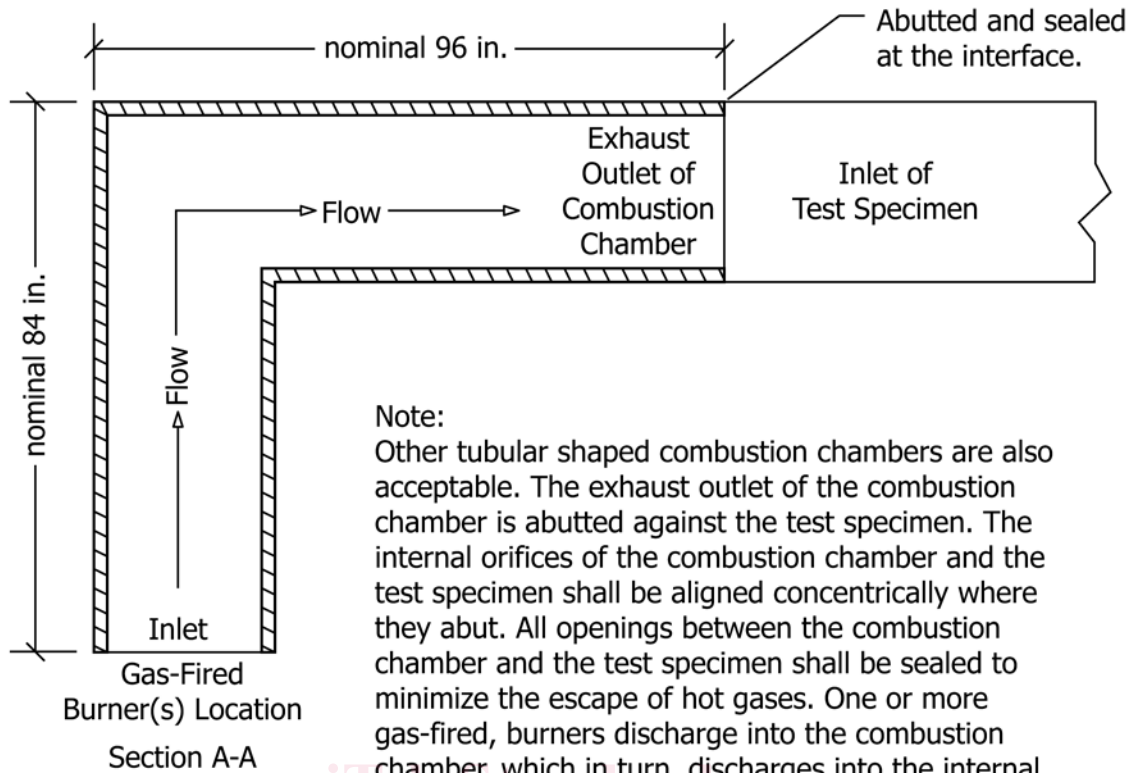

Note:
Other tubular shaped combustion chambers are also acceptable. The exhaust outlet of the combustion chamber is abutted against the test specimen. The internal orifices of the combustion chamber and the test specimen shall be aligned concentrically where they abut. All openings between the combustion chamber and the test specimen shall be sealed to minimize the escape of hot gases. One or more gas-fired, burners discharge into the combustion chamber, which in turn, discharges into the internal cavity of the test specimen.

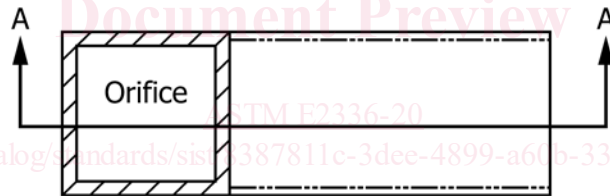

FIG. 1 A Rectangular Combustible Chamber

6.7.1 The thermocouple pads used to cover each thermocouple on the unexposed side of the test specimen or test assembly shall be made of either asbestos or refractory fiber materials. All thermocouple pads shall be square and measure $6 \pm \frac{1}{8}$ in. (152 ± 3 mm) on each side. The properties of the thermocouple pads shall have the following characteristics in 6.7.1.1 or 6.7.1.2.

NOTE 6—There are potential health concerns associated with the use of asbestos pads. Most, if not all United States' laboratories do not use asbestos pads. Further, in the United States these pads are very difficult to acquire. However, ASTM International standards are used internationally and some countries still use the asbestos pads.

6.7.1.1 Asbestos Pads

(a) Thermocouple pads shall be dry, felted amosite asbestos, and free of organic additives.

(b) The thermocouple pads shall be 0.40 ± 0.05 in. (10.2 ± 1.3 mm) thick. The thickness measurement shall be made under

the light load of a standard $\frac{1}{2}$ -in. (12.7-mm) diameter pad of a dial micrometer gage.

(c) The thermocouple pads shall have a dry weight of 0.260 ± 0.026 lb (0.12 ± 0.01 kg).

(d) The thermal conductivity of the thermocouple pads at 150°F (66°C) shall be 0.38 ± 0.027 Btu-in./h-ft²-°F [0.055 ± 0.003 W/(m-°K)].

(e) The thermocouple pads shall have a hardness (on soft face) of 1.57 ± 0.07 in. (4.0 ± 1.8 mm) or 10-25 (modified Brinell). Indentation shall be determined in accordance with Test Method C569. Modified Brinell values of hardness shall be obtained by the relationship:

$$\text{Hardness} = 2.24/y \tag{2}$$

where:

y = the measured indentation, in. (mm).

- 1. Furnace
- 2. Exhaust Flue
- 3. View Ports
- 4. Access Door
- 5. Gas Burners
- 6. Thermocouple Tube Locations
- 7. Test Specimen Location

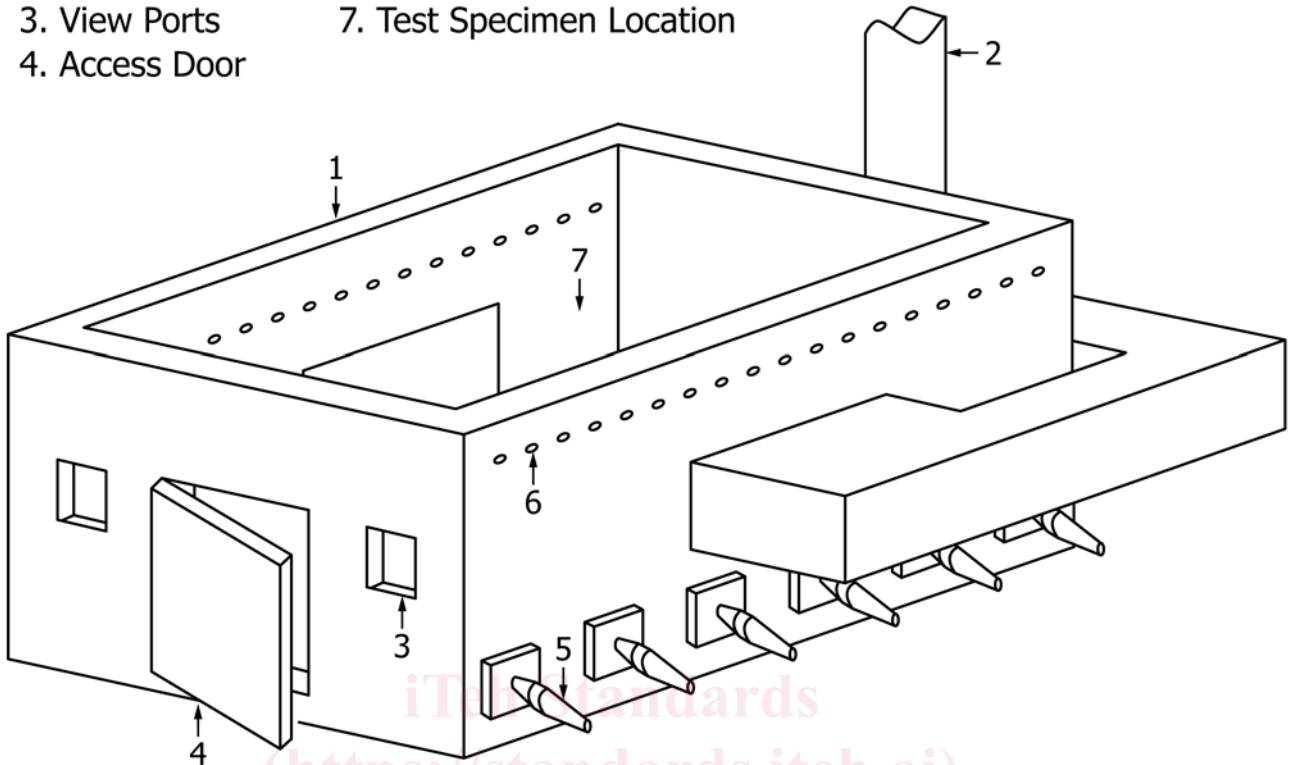

NOTE 1—The test specimen is lowered into the furnace and held up by the supporting construction.

FIG. 2 A Horizontal Furnace

6.7.1.2 Refractory Fiber Pads

(a) Thermocouple pads shall be dry, felted refractory fiber pads.

(b) The thermocouple pads shall be 0.375 ± 0.063 in. (9.5 ± 1.6 mm) thick. The thickness measurement shall be made under the light load of a standard $\frac{1}{2}$ -in. (12.7-mm) diameter pad of a dial micrometer gage.

(c) The thermocouple pads shall have a dry weight of 0.147 ± 0.053 lb (67 ± 24 g).

(d) The thermal conductivity of the thermocouple pads at 150°F (66°C) shall be 0.37 ± 0.03 Btu-in./h-ft²-°F [0.053 ± 0.004 W/(m·°K)].

(e) The thermocouple pads shall have a hardness (on soft face) of 0.75 ± 0.025 in. (1.9 ± 0.6 mm). Indentation shall be determined in accordance with Test Method C569. Modified Brinell values of hardness shall be obtained by the relationship:

$$\text{Hardness} = 2.24/y \quad (3)$$

where:

y = the measured indentation, in. (mm).

6.8 Differential Pressure Measurement Instruments:

6.8.1 The differential pressure measurement instrument shall be:

6.8.2 A manometer or equivalent transducer

6.8.3 Capable of reading in graduated increments of no greater than 0.01 in. H₂O (2.5 Pa) with a precision of not less than ± 0.005 in. H₂O (± 1.25 Pa).

6.9 Hose Stream Delivery System:

6.9.1 The hose stream delivery system shall consist of:

6.9.1.1 A standard $2\frac{1}{2}$ -in. (64-mm) diameter hose attached to a national standard play pipe as described in UL 385.

6.9.1.2 The play pipe shall have a length of $30 \pm \frac{1}{4}$ in. (762 ± 6 mm) and shall be equipped with a standard $1\frac{1}{8}$ -in. (29-mm) discharge tip of the standard-taper-smooth-bore pattern without shoulder at the orifice.

6.9.1.3 The play pipe shall be fitted with a standard $2\frac{1}{2}$ -in. (64-mm) inside dimension by 6-in. (153-mm) long nipple mounted between the hose and the base of the play pipe.

6.9.1.4 A pressure tap for measuring the water pressure at the base of the nozzle shall be normal to the surface of the nipple, shall be centered in its length, and shall not protrude into the water stream.

6.9.1.5 A suitable pressure gage capable of reading a minimum of 0-50 psi (0-344.8 kPa) and graduated into no greater than 2-psi (13.8-kPa) increments shall be used to measure the water pressure.

7. Sampling, Units, Test Specimens, and Test Assemblies

NOTE 7—Some evaluation services require an approved inspection agency or certification body to witness the enclosure material production to establish traceability to the test specimens and that the enclosure material be representative of the product as applied in the field. Enclosure materials are normally required to be classified as noncombustible, as defined by the International Building Code (2000).

7.1 Noncombustibility Test Specimens:

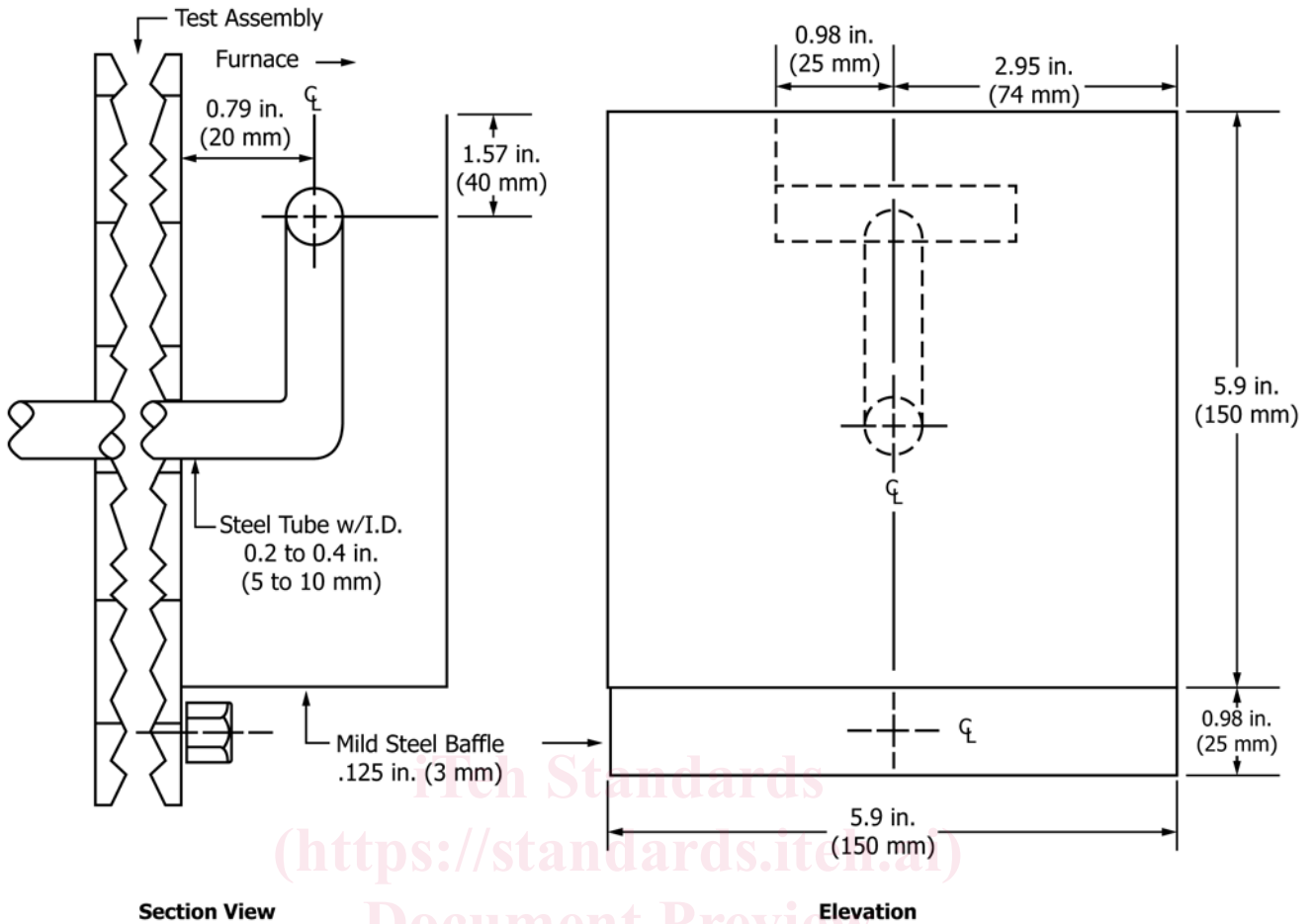

FIG. 3 T-Shaped Pressure Sensor

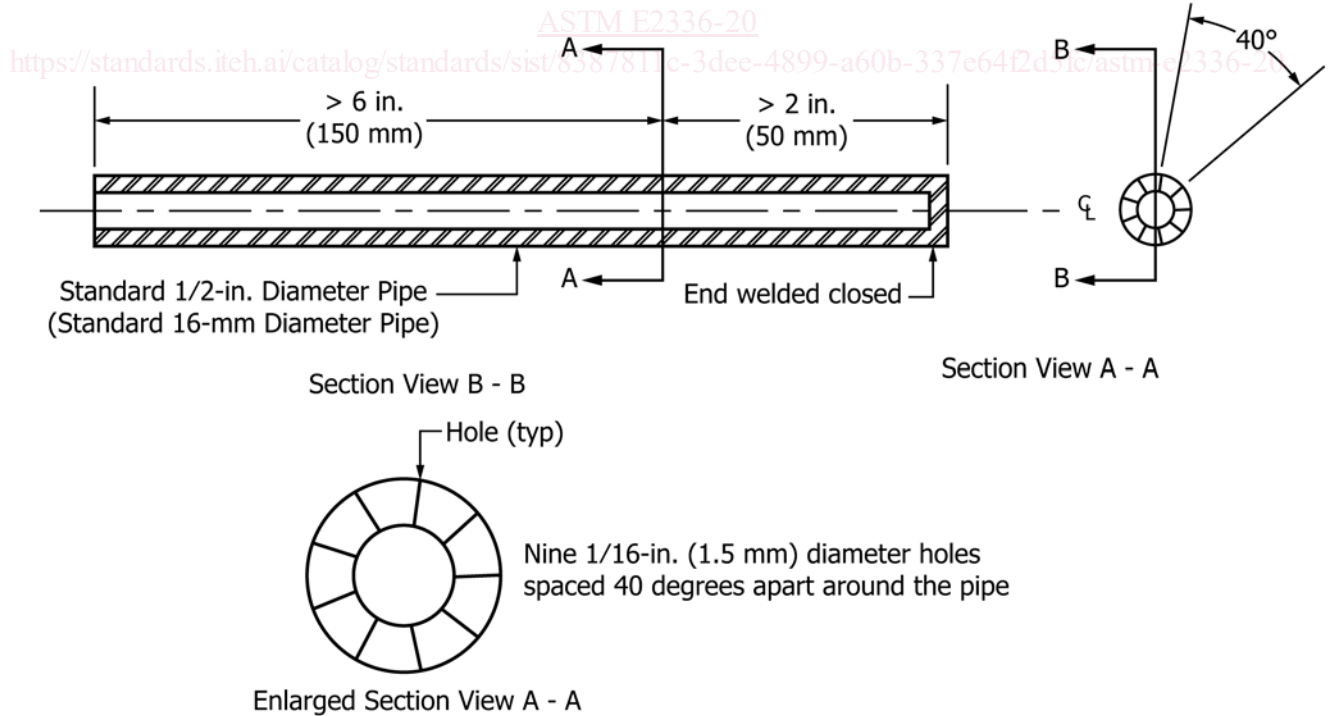

FIG. 4 Tube Sensor