



Designation: B898 – 20

Standard Specification for Reactive and Refractory Metal Clad Plate¹

This standard is issued under the fixed designation B898; the number immediately following the designation indicates the year of original adoption or, in the case of revision, the year of last revision. A number in parentheses indicates the year of last reappraisal. A superscript epsilon (ϵ) indicates an editorial change since the last revision or reappraisal.

1. Scope

1.1 This specification covers plate consisting of a base metal to which is bonded, integrally and continuously, on one or both sides a layer of one of the following: titanium, zirconium, tantalum, niobium, and their alloys. The material generally is intended for pressure vessel use.

1.2 The values stated in inch-pound units are to be regarded as standard. The values given in parentheses are mathematical conversions to SI units that are provided for information only and are not considered standard. The values in parentheses and in metric tables are provided for information only.

1.3 *This international standard was developed in accordance with internationally recognized principles on standardization established in the Decision on Principles for the Development of International Standards, Guides and Recommendations issued by the World Trade Organization Technical Barriers to Trade (TBT) Committee.*

2. Referenced Documents

2.1 ASTM Standards:²

- [B265 Specification for Titanium and Titanium Alloy Strip, Sheet, and Plate](#)
- [B393 Specification for Niobium and Niobium Alloy Strip, Sheet, and Plate](#)
- [B551/B551M Specification for Zirconium and Zirconium Alloy Strip, Sheet, and Plate](#)
- [B708 Specification for Tantalum and Tantalum Alloy Plate, Sheet, and Strip](#)
- [E114 Practice for Ultrasonic Pulse-Echo Straight-Beam Contact Testing](#)

¹ This specification is under the jurisdiction of ASTM Committee B10 on Reactive and Refractory Metals and Alloys and is the direct responsibility of Subcommittee B10.01 on Titanium.

Current edition approved April 1, 2020. Published April 2020. Originally approved in 1999. Last previous edition approved in 2019 as B898 – 19. DOI: 10.1520/B0898-20.

² For referenced ASTM standards, visit the ASTM website, www.astm.org, or contact ASTM Customer Service at service@astm.org. For *Annual Book of ASTM Standards* volume information, refer to the standard's Document Summary page on the ASTM website.

2.2 ASME Code:³

[Boiler and Pressure Vessel Code, Section IX Welding Qualifications](#)

[Boiler and Pressure Vessel Code, Section VIII Divisions 1, 2, 3](#)

2.3 Military Standard:⁴

[MIL-J-24445A Joint, Bimetallic Bonded, Aluminum to Steel](#)

2.4 ASNT Standards:⁵

[SNT-TC-1A Recommended Practice No. SNT-TC-1A Personnel Qualification and Certification in Nondestructive Testing](#)

3. Terminology

3.1 Definitions of Terms Specific to This Standard:

3.1.1 This material is considered as single-clad or double-clad dependent upon whether one or both sides of the base metal are covered by a cladding metal.

3.1.2 *base metal, n*—the component that comprises the greatest percentage of total thickness.

3.1.3 *cladding metal, or cladding metals, n*—the component, or components, which individually comprise less than the greatest percentage of total thickness.

3.1.4 *cladding operation, n*—the production event, which results in the formation of the bond between the cladding and base metal components, plus all related prebonding and post bonding operations, prior to supply to the purchaser.

3.1.5 *interface, n—of the clad product*, is that region of thickness in which the product transitions from essentially 100 % base metal to 100 % cladding metal. Also known as bond or bond zone.

3.1.6 *interlayer, n*—a metal layer of a type or grade different from the cladding metal and base metal, which is applied between the cladding and base metal.

³ Available from American Society of Mechanical Engineers (ASME), ASME International Headquarters, Three Park Ave., New York, NY 10016-5990, <http://www.asme.org>.

⁴ Available from DLA Document Services, Building 4/D, 700 Robbins Ave., Philadelphia, PA 19111-5094, <http://quicksearch.dla.mil>.

⁵ Available from American Society for Nondestructive Testing (ASNT), P.O. Box 28518, 1711 Arlington Ln., Columbus, OH 43228-0518, <http://www.asnt.org>.

3.1.7 *integrally and continuously bonded, adv*—a condition in which the cladding metal and base metal are brought together to form a metallurgical bond at essentially the entire interface of the two metals by means other than those processes that do not produce a homogeneous composite plate.

4. Ordering Information

4.1 Orders for material under this specification shall include the following information:

4.1.1 Quantity.

4.1.2 Product dimensions, including thickness of both cladding metal and base metal. It should state whether each thickness value is minimum or nominal. If not stated, thickness values shall be nominal.

4.1.3 Cladding metal type and specification (the cladding metal specification) (see Section 6).

4.1.4 Base metal type and specification (the base metal specification) (see Section 6).

4.1.5 Flatness requirements (see 10.3).

4.1.6 Ultrasonic inspection level (see Section 11).

4.1.7 Heat treatment requirements, if any.

4.1.8 Restrictions limiting or disallowing welding, or weld repair, or both, if any (see Section 12).

4.1.9 Any additional codes and standards specified by the purchaser or manufacturer.

4.1.10 Supplementary Requirements, if any.

4.1.11 Additional requirements, if any.

5. Materials and Manufacture

5.1 *Process*:

5.1.1 The base metal shall be manufactured in accordance with all applicable requirements of the base metal specification (see 4.1.4).

5.1.2 The cladding metal shall be manufactured in accordance with all applicable requirements of the cladding metal specification (see 4.1.3).

5.1.3 The cladding metal shall be bonded to the base metal by any cladding operation that will produce a clad product which will conform to the requirements of this specification. Cladding methods may be, but are not limited to, explosion bonding, roll bonding, and weld overlay.

5.1.4 The cladding metal may be fabricated from multiple sheets or plates by edge butt welding prior to the cladding operation.

5.1.5 The cladding thickness may consist of multiple layers of the cladding metal.

5.2 *Heat Treatment*—Unless otherwise specified or agreed between the purchaser and the manufacturer, all heat treatments shall be performed as needed in the cladding operation to assure the following:

5.2.1 The cladding metal conforms to the applicable requirements of the cladding metal specification,

5.2.2 The base metal conforms to the applicable requirements of the base metal specification, and

5.2.3 The clad bond exhibits optimum resistance to disbonding during common fabrication processes.

6. Chemical Composition

6.1 The composite plate may conform to any desired combination of cladding metal and base metal as described in 6.2 and 6.3 and as agreed upon between the purchaser and the manufacturer.

6.2 *Cladding Metal*—The cladding metal shall conform to the requirements as to chemical composition prescribed in the applicable cladding metal specification: **B265**, **B393**, **B551/B551M**, or **B708**.

6.3 *Base Metal*—The base metal shall be steel or any other product conforming to specifications for metal plate. The base metal shall conform to the requirements as to chemical composition prescribed in the base metal specification.

7. Mechanical Properties

7.1 The base metal shall conform to the mechanical property requirements prescribed in the base metal specification.

7.2 The mechanical properties of the cladding metal may not conform necessarily to the mechanical property requirements prescribed in the cladding metal specification unless otherwise agreed upon between manufacturer and purchaser.

7.3 Mechanical testing of the base metal, in accordance with the base metal specification, may be performed prior to the cladding operation if the cladding operation does not affect the applicable mechanical properties of the base metal.

7.4 Unless simulated post cladding heat treatments are specified by the purchaser, Supplementary Requirement S5, the mechanical test specimens shall be representative of the material in the heat treatment condition of product being shipped from the clad manufacturer.

7.5 *Tensile Strength Requirements*—The tensile properties shall be determined by a tension test on the base metal only in accordance with the testing requirements of the base metal specification. When tension test specimen are taken from the clad plate, the cladding shall be removed before tension tests are made.

7.6 *Bond Shear Strength Testing*:

7.6.1 A bond shear strength test shall be performed on each clad plate. The minimum permissible shear strength shall be 20 000 psi (137.9 MPa).

7.6.2 The specimen shall be taken from an end of the plate. When the clad plate is produced by explosion cladding, the specimen shall be from a location which is typical of the maximum distance from the initiation point. The specimen shall be prepared and tested in the manner of **Fig. 1**.

7.6.3 Retesting shall be permitted only when the test specimen or test method is defective. When retesting is performed, two test specimens shall be obtained from a location adjacent to the original specimen. The shear strength values of both must exceed the minimum specified value. Only one set of retests is allowed.

7.6.4 The results of all tests and all retests shall be included in the Material Test Report, paragraph 16.1.2.

8. Chemical Analysis

8.1 When the cladding operation does not affect the chemical composition of the cladding or base metal, or both, the

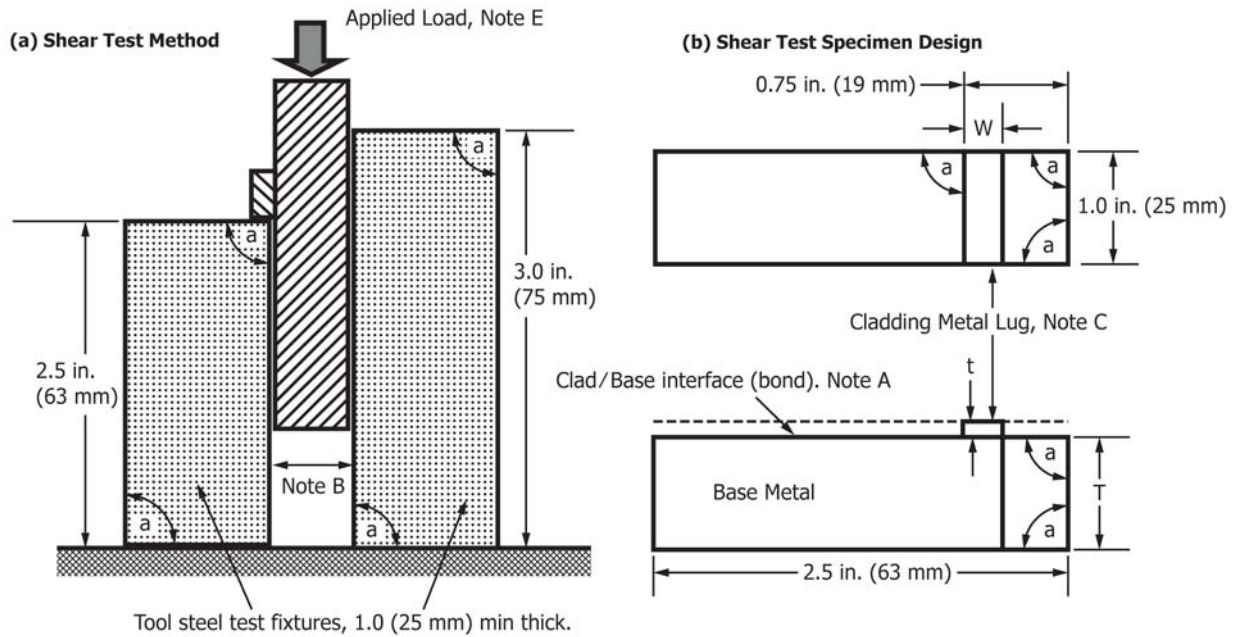

	in.	mm	Other	Comment
W	—	—	$1.5t \leq W \leq 3t$	—
t	≤ 0.125	≤ 3.2	—	Note 3
T	≤ 1.00	≤ 25.4	—	Note 4
Angle "a"	—	—	$90^\circ (\pm 0.1^\circ)$	—

NOTE 1—The cladding metal shall be removed (machined) from the base metal over the full interface surface except for the area of the clad metal test lug. The machined surface shall lie within ± 0.001 in. (0.05 mm) of the interface (bondzone). If the bond has a wave morphology, the interface shall be defined as the centerline of the wave height.

NOTE 2—Shear blocks shall be bolted (or otherwise fixtured) rigidly together with a spacing sufficient to allow the specimen to slide freely but not to exceed the specimen thickness by >0.005 in. (0.12 mm).

NOTE 3—When cladding metal thickness is >0.125 in. (3.2 mm), the thickness of the cladding metal test lug (t) shall be machined to 0.125 in. When cladding metal thickness is <0.125 in., the lug thickness is to be as-clad.

NOTE 4—When base metal is >1.0 in. (25.4 mm), the specimen thickness is to be machined to 1.0 in. When base metal thickness is ≤ 1.0 in., the back side face is to be machined as needed to produce parallel front and back faces.

NOTE 5—Test loading rate not to exceed 0.4 in./min (10 mm).

FIG. 1 Shear Strength Test Specimen and Test Method

chemical analysis, in accordance with cladding, or base metal specifications, or both, may be performed prior to the cladding operation. Otherwise, chemical analysis of the applicable component or components shall be performed after the cladding operation in accordance with the cladding metal or base metal specifications, or both.

8.2 When chemical analysis of the finished product is invoked, Supplementary Requirement S4, the frequency of testing, specimen location, and testing methods shall be agreed upon between manufacturer and purchaser.

9. Location and Number of Tests and Retests

9.1 *Tension, Bend, and Impact Tests (When Required)*—The specimen orientation, location with respect to thickness, and number of tests and retests shall be in accordance with the requirements of the base metal specification. The test specimen location within the plate shall be at the manufacturer's option.

10. Dimensions and Flatness, Permissible Variations

10.1 Thickness:

10.1.1 Cladding metal thickness tolerances shall be in accordance with Table 1.

10.1.2 Base metal thickness tolerances shall be in accordance with Table 2.

TABLE 1 Cladding Metal Thickness Tolerance

	When Cladding Metal Thickness is Specified			
	Minimum	Nominal	Nominal	Nominal
Specified Thickness	≤ 0.150 in.	>0.150 in.	<0.188 in.	≥ 0.188 in.
Undergage Tolerance	0	0	0.030 in.	0.060 in.
Overgage Tolerance	100 % of minimum	50 % of minimum	100 % of nominal	50 % of nominal

TABLE 1M Cladding Metal Thickness Tolerance

	When Cladding Metal Thickness is Specified			
	Minimum	Nominal	Nominal	Nominal
Specified Thickness	≤ 3.8 mm	>3.8 mm	<4.8 mm	≥ 4.8 mm
Undergage Tolerance	0	0	0.75 mm	1.5 mm
Overgage Tolerance	100 % of specified minimum	50 % of specified minimum	100 % of nominal	50 % of nominal

TABLE 2 Base Metal Thickness Tolerance

	When Base Metal Thickness is Specified			
	Minimum		Nominal	
Specified Thickness	<1.0 in.	≥1.0 in.	<1.0 in.	≥1.0 in.
Undergage Tolerance	0	0	0.01 in.	0.01 in.
Overgage Tolerance	0.21 in. over min	0.26 in. over min	0.20 in. over nominal	0.25 in. over nominal

TABLE 2M Base Metal Thickness Tolerance

	When Base Metal Thickness is Specified			
	Minimum		Nominal	
Specified Thickness	<25.4 mm	≥25.4 mm	<25.4 mm	≥25.4 mm
Undergage Tolerance	0	0	0.25 mm	0.25 mm
Overgage Tolerance	5.3 over specified minimum	6.6 over specified minimum	5.1 over specified nominal	6.4 over specified nominal

10.1.3 When the purchaser specifies flatness in accordance with 10.3.1.3 or 10.3.1.4, overgage tolerances in excess of those specified herein may be specified by the manufacturer.

10.1.4 When agreed upon by the producer and the purchaser, overgage tolerances different from those specified herein shall apply.

10.1.5 When an interlayer metal is included in the product and when its thickness exceeds 0.005 in. (0.127 mm) nominal, its composition and nominal thickness shall be reported.

10.2 Length and Width or Diameter Tolerances:

10.2.1 Clad plates shall be supplied with edges cut to the dimensions specified by the purchaser. Cutting may be performed by thermal or mechanical means or any other method, which does not deleteriously affect the product quality. Clad plates shall conform to the length and width or diameter tolerances of Table 3 unless otherwise agreed upon between the manufacturer and purchaser.

10.2.2 When specified by the purchaser, clad plate shall be supplied in the as-clad or mill edge, condition. Minimum sound bond size shall be specified, and length and width tolerances of the as-supplied product shall be as agreed upon between purchaser and manufacturer. All edge nonbond areas outside of the specified minimum sound bond area shall be marked clearly on the surface, or the boundary of the required sound bond area shall be marked clearly on the sound bond portion of the surface, or both.

10.3 Flatness:

TABLE 3 Length and Width, or Diameter, Tolerance

Total Thickness	Permissible Variation from Specified Length and Widths or Diameter
<2.0 in.	-0, +0.8 in.
≥2.0 in., <4.0 in.	-0, +1.0 in.
≥4.0 in., <8.0 in.	-0, +1.5 in.
≥8.0 in.	per agreement

TABLE 3M Length and Width, or Diameter, Tolerance

Total Thickness	Permissible Variation from Specified Length and Widths or Diameter
<50 mm	-0, +20 mm
≥50, <100	-0, +25 mm
≥100, <200	-0, +38 mm
≥200 mm	per agreement

10.3.1 Flatness of the clad plate shall be in accordance with one of the following flatness tolerance requirements. When flatness requirements are not specified by the purchaser, flatness tolerances of 10.3.1.1 shall apply.

10.3.1.1 *Standard Plate Flatness*—Out-of-flatness of the cladding face shall not exceed the requirements of Table 4. This flatness criteria typically is applicable for clad plates intended for subsequent forming, or fabrication, or both.

10.3.1.2 *Special Flatness*—Out-of-flatness of the cladding face shall not exceed 0.100 in. (2.5 mm) over any 36-in. (915-mm) span. This flatness criteria typically is applicable for plates used in the flat condition.

10.3.1.3 *Machined Flatness*—Out-of-flatness of one or both faces, as specified by the purchaser, shall not exceed 0.010 in. (0.25 mm) over any 36-in. (915-mm) span.

10.3.1.4 *Suitable for Machining Flat*—The material shall be supplied in a condition suitable for subsequent machining of specified face or faces while protecting minimum specified thickness. The combination of the flatness of the product and the thickness of the component metals shall permit the cladding metal, or the base metal, or both, as specified by the purchaser, to be machined to the requirements of 10.3.1.3 without reducing thickness below the minimum specified, upon application of proper set-up and machining practice.

10.3.1.5 *Other Flatness*—Other flatness requirements may be agreed upon mutually between the manufacturer and the purchaser.

TABLE 4 Permissible Variations in Flatness of Cladding Metal Surface

Total Thickness (in.)	Maximum Out-of-Flatness Over any 36 in. ^{A,B,C,D}	Maximum Out-of-Flatness Over any 72 in. ^{E,A,D}
<0.50	0.38	0.56
≥0.50 <1.0	0.31	0.47
≥1.0 <6.0	0.25	0.38
≥6.0	to be agreed upon	to be agreed upon

^A Flatness is measured by placing a straight edge of 36-in. length or a straight edge of 72-in. on the plate surface, or both, and then measuring the maximum deviation between the plate surface and the straight edge. Balancing of the straight edge on a high point is an acceptable measurement technique.

^B For plate dimensions between 36 in. and 72 in., only the 36 in. shall apply.

^C For plate dimensions less than 36 in., the maximum out of flatness shall be the ratio of (applicable dimension / 36 in.) × (above value for 36-in. measurement).

^D This flatness criteria shall apply to the total cladding metal surface. Measurements are required only as needed to assure that this requirement is met.

^E For plate dimensions exceeding 72 in., both the 36-in. and 72-in. measurements shall apply.

TABLE 4M Permissible Variations in Flatness of Cladding Metal Surface

Total Thickness (mm)	Maximum Out-of-Flatness mm Over any 915 mm ^A	Maximum Out-of-Flatness mm Over any 1830 mm ^{B,C,D,E}
<12.7	9.7	14.2
≥12.7 <25.4	7.9	11.9
≥25.4 <150	6.3	9.7
≥152	to be agreed upon	to be agreed upon

^A Flatness is measured by placing a straight edge of 915-mm length or a straight edge of 1830 mm on the plate surface, or both, and then measuring the maximum deviation between the plate surface and the straight edge. Balancing of the straight edge on a high point is an acceptable measurement technique.

^B For plate dimensions exceeding 1830 mm, both the 915 and 1830 measurements shall apply.

^C For plate dimensions between 915 and 1830, only the 915 shall apply.

^D For plate dimensions less than 915, the maximum out of flatness shall be the ratio of (applicable dimension / 915) × (above value for 915 measurement)

^E This flatness criteria shall apply to the total cladding metal surface. Measurements are required only as needed to assure that this requirement is met.