



Designation: D971 – 20

Standard Test Method for Interfacial Tension of Insulating Liquids Against Water by the Ring Method¹

This standard is issued under the fixed designation D971; the number immediately following the designation indicates the year of original adoption or, in the case of revision, the year of last revision. A number in parentheses indicates the year of last reappraisal. A superscript epsilon (ϵ) indicates an editorial change since the last revision or reappraisal.

This standard has been approved for use by agencies of the U.S. Department of Defense.

1. Scope

1.1 This test method covers the measurement of the interfacial tension between insulating liquid that has a relative density (specific gravity) less than water and water, under non-equilibrium conditions.

1.2 *This standard does not purport to address all of the safety concerns, if any, associated with its use. It is the responsibility of the user of this standard to establish appropriate safety, health, and environmental practices and determine the applicability of regulatory limitations prior to use. See 7.2 for a specific warning statement.*

1.3 *This international standard was developed in accordance with internationally recognized principles on standardization established in the Decision on Principles for the Development of International Standards, Guides and Recommendations issued by the World Trade Organization Technical Barriers to Trade (TBT) Committee.*

2. Referenced Documents

- 2.1 *ASTM Standards:*²
[D923 Practices for Sampling Electrical Insulating Liquids](#)

3. Summary of Test Method

3.1 *Interfacial Tension* is determined by measuring the force necessary to detach a planar ring of platinum wire from the surface of the liquid of higher surface tension, that is, upward from the water insulating liquid interface. To calculate the interfacial tension, the force so measured is corrected by an empirically determined factor which depends upon the force applied, the densities of both the insulating liquid and water, and the dimensions of the ring. Measurements are made under

¹ This test method is under the jurisdiction of ASTM Committee D27 on Electrical Insulating Liquids and Gases and is the direct responsibility of Subcommittee D27.07 on Physical Test.

Current edition approved April 1, 2020. Published May 2020. Originally approved in 1948 as D971 – 48 T. Last previous edition approved in 2012 as D971 – 12. DOI: 10.1520/D0971-20.

² For referenced ASTM standards, visit the ASTM website, www.astm.org, or contact ASTM Customer Service at service@astm.org. For *Annual Book of ASTM Standards* volume information, refer to the standard's Document Summary page on the ASTM website.

rigidly standardized nonequilibrium conditions in which the measurement is completed within 60 s after formation of the interface.

4. Significance and Use

4.1 Interfacial tension measurements on electrical insulating liquids provide a sensitive means of detecting small amounts of soluble polar contaminants and products of oxidation. A high value for new mineral insulating oil indicates the absence of most undesirable polar contaminants. The test is frequently applied to service-aged mineral oils as an indication of the degree of deterioration.

NOTE 1—Different liquid matrixes are reviewed in [Appendix X1](#).

5. Apparatus (Figs. 1 and 2)

5.1 *Tensiometer*³—Force measurement on the tensiometer may be made using a torsion wire, load cell, or any other means of linearly determining tension in the range of 0 to 100 mN/m.

5.1.1 Horizontal platform to hold the sample container should be capable of movement upward or downward using a mechanical screw, lever mechanism, electronic drive, or any other means of precisely changing vertical position of the sample.

5.2 Rings made of platinum or platinum-iridium alloy may be used. The ring should be welded into a continuous circle and attached to at least two parallel stirrups. Circumference of the ring should be minimum 40 mm and diameter of the ring wire should be about 0.3 mm. Ratio of the ring major radius (R) and the wire radius (r) should be known (R/r) to at least three significant figures. Stirrups should be at least 25 mm long.

5.2.1 The ring may be suspended from or rigidly fixed into the tensiometer force measuring system.

5.3 *Sample Container*—Glass beaker or clear cylindrical container having a minimum diameter of 45 mm.

6. Reagents

6.1 *Purity of Reagents*—Reagent grade chemicals shall be used in the test.

³ Tensiometers that use the Du Nouy principle for measuring interfacial and surface tension should be used.

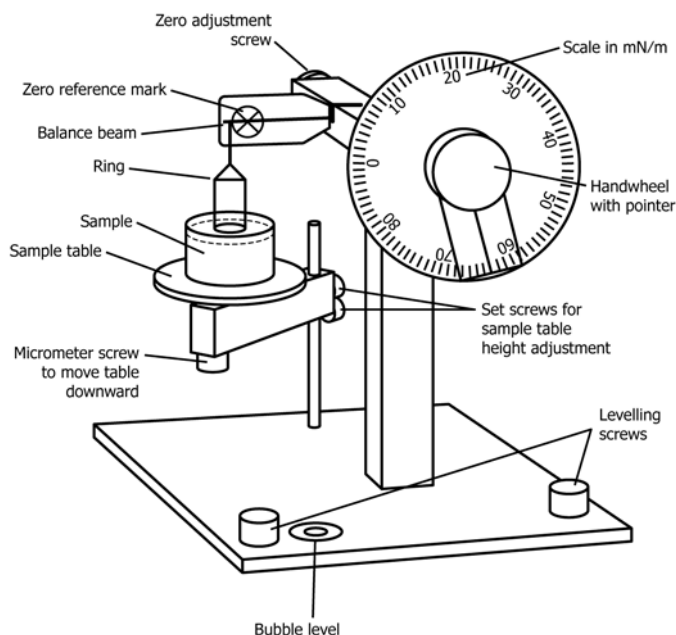

FIG. 1 Manual Interfacial Tensiometer

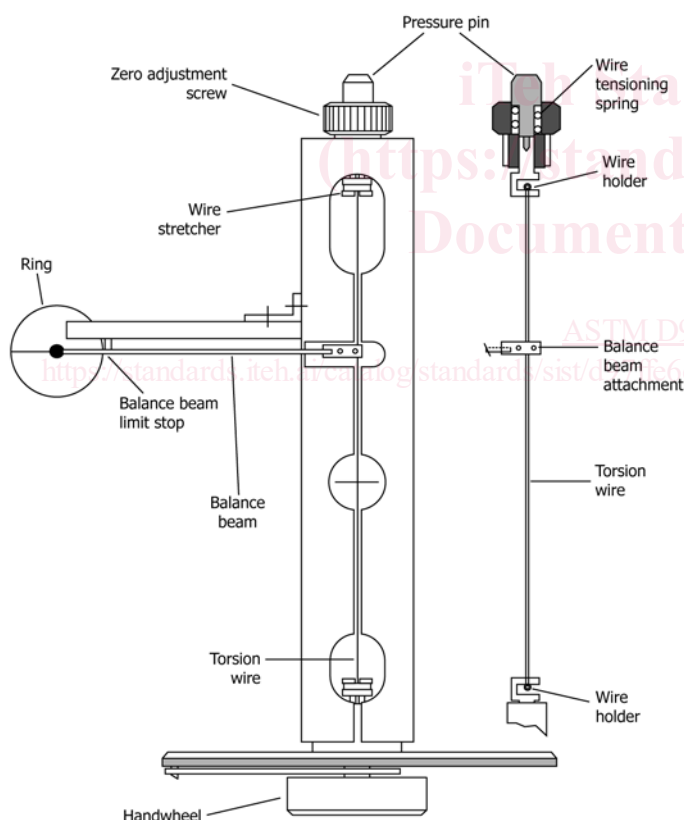

FIG. 2 Top View of Manual Interfacial Tensiometer

6.2 *Purity of Water*—Unless otherwise indicated, references to water shall be understood to mean distilled water or water of equal purity.

7. Preparation of Apparatus

7.1 Glass containers can be cleaned by rinsing in xylene, hexane or another suitable hydrocarbon solvent, followed by a

rinse in acetone or methyl ethyl ketone. Following these rinses they can be cleaned using detergent in hot water and rinsed thoroughly with tap and then distilled water. Dry the glass vessel if not for immediate use.

7.2 The ring should be cleaned by immersing it in a small container of xylene, hexane or another suitable hydrocarbon solvent for at least 5 s while spinning the ring back and forth. Next, repeat this rinse using a container filled with acetone or methyl ethyl ketone. Flame the ring in a gas flame making sure all areas that will contact liquid obtain rapid, uniform heating. The ring should barely glow orange and should be heated for no more than 5 s. Clean the ring immediately before each measurement. (**Warning**—Solvents are extremely flammable. Take precautions to keep all flammable and combustible materials away from the flame.)

7.3 The tensiometer should be leveled by placing a bubble level device on the sample platform, if not equipped with one, and adjusting the tensiometer base until the platform is level.

8. Calibration of Apparatus

8.1 Calibrate the tensiometer against known weights and adjust its zero point according to the procedure of its manufacturer. Make certain that all portions of the ring are in the same horizontal plane.

9. Procedure

9.1 Preparation of Test Specimens:

9.1.1 Obtain a representative test specimen of liquid to be studied in accordance with Practices D923.

9.1.2 Obtain a fresh aliquot of distilled water at room temperature for interfacial tension measurements.

9.1.3 Test specimens and distilled water should be covered, capped, or sealed immediately after they are obtained. Atmospheric dust and vapor can easily contaminate water, as can the growth of bacteria. Store test specimen and distilled water at room temperature.

9.1.4 Temperature of test specimen and temperature of distilled water should agree within $\pm 1^\circ\text{C}$.

9.2 Determination of Test Specimen Density:

9.2.1 Determine test specimen density at room temperature using a liquid pycnometer or other density measuring device to ± 0.001 g/mL.

9.3 Interfacial Tension Measurement:

9.3.1 Introduce distilled water at room temperature into a clean sample container to a depth of 10 to 15 mm. Place it on the tensiometer platform so that the ring comes down in the center of the container and is not close to any wall. Make sure no foam is present at the water surface. If foam is visible, discard the water. Foam indicates that the water is contaminated or that the vessel is not clean.

9.3.2 Clean the ring and mount it in the tensiometer. For manual tensiometers, follow the manufacturer's instructions on zeroing the ring in air.

9.3.3 Raise the platform until the ring is immersed to a depth not to exceed 6 mm into the water.

9.3.4 For manual tensiometers, slowly lower the platform and follow the manufacturer's instructions on how to adjust the