



Designation: E576 – 14 (Reapproved 2020)

Standard Test Method for Frost/Dew Point of Sealed Insulating Glass Units in the Vertical Position¹

This standard is issued under the fixed designation E576; the number immediately following the designation indicates the year of original adoption or, in the case of revision, the year of last revision. A number in parentheses indicates the year of last reapproval. A superscript epsilon (ϵ) indicates an editorial change since the last revision or reapproval.

This standard has been approved for use by agencies of the U.S. Department of Defense.

1. Scope

1.1 This test method describes a field or laboratory procedure for determining the frost/dew point within the air space(s) of sealed insulating glass units and establishes the criteria for determining whether that point is below or above a given or specified temperature.

1.2 This test method also describes the apparatus to be used for these determinations.

1.3 The values stated in inch-pound units are to be regarded as standard. The values given in parentheses are mathematical conversions to SI units that are provided for information only and are not considered standard.

1.4 *This standard does not purport to address all of the safety concerns, if any, associated with its use. It is the responsibility of the user of this standard to establish appropriate safety, health, and environmental practices and determine the applicability of regulatory limitations prior to use.* For specific hazard statements, see 9.1.3 and 9.3.8.

1.5 *This international standard was developed in accordance with internationally recognized principles on standardization established in the Decision on Principles for the Development of International Standards, Guides and Recommendations issued by the World Trade Organization Technical Barriers to Trade (TBT) Committee.*

2. Referenced Documents

2.1 *ASTM Standards:*²

[C1036 Specification for Flat Glass](#)

¹ This test method is under the jurisdiction of ASTM Committee E06 on Performance of Buildings and is the direct responsibility of Subcommittee E06.22 on Durability Performance of Building Constructions.

Current edition approved May 1, 2020. Published May 2020. Originally approved in 1976. Last previous edition approved in 2014 as E576–14. DOI: 10.1520/E0576-14R20.

² For referenced ASTM standards, visit the ASTM website, www.astm.org, or contact ASTM Customer Service at service@astm.org. For *Annual Book of ASTM Standards* volume information, refer to the standard's Document Summary page on the ASTM website.

[E77 Test Method for Inspection and Verification of Thermometers](#)

[E631 Terminology of Building Constructions](#)

[E774 Specification for the Classification of the Durability of Sealed Insulating Glass Units \(Withdrawn 2006\)](#)³

3. Terminology

3.1 *Definitions*—For definitions of general terms used in this test method, refer to Terminology [E631](#).

3.2 *Definitions of Terms Specific to This Standard:*

3.2.1 *frost/dew point*—the temperature at which water, organic vapor, or other chemicals begin to appear on the interior glass surface of a sealed insulating glass unit in contact with the measuring surface of the frost/dew-point apparatus.

3.2.2 *frost state*—the case where the frost/dew point of a sealed insulating glass unit is above the test temperature specified by the purchaser or user.

3.2.3 *no-frost state*—the case where the frost/dew point of a sealed insulating glass unit is below the temperature specified by the purchaser or user.

4. Summary of Test Method

4.1 This test method is conducted by the use of a special apparatus, consisting basically of two chilled cylindrical metal blocks positioned one over the other and separated by a gap of controllable distance. The upper block has an exposed flat circular surface, 1 in. (25 mm) in diameter, and can be chilled to far below the ice point by regulating the air gap distance between it and the lower metal block which is maintained at approximately -109°F (-78°C) by dry ice. The test specimen is placed in contact with this chilled flat circular surface of the upper block for specified short periods of time, with the metal surface at successively lower temperatures, to determine at what temperature frost appears on the corresponding lower air space glass surface.

³ The last approved version of this historical standard is referenced on www.astm.org.

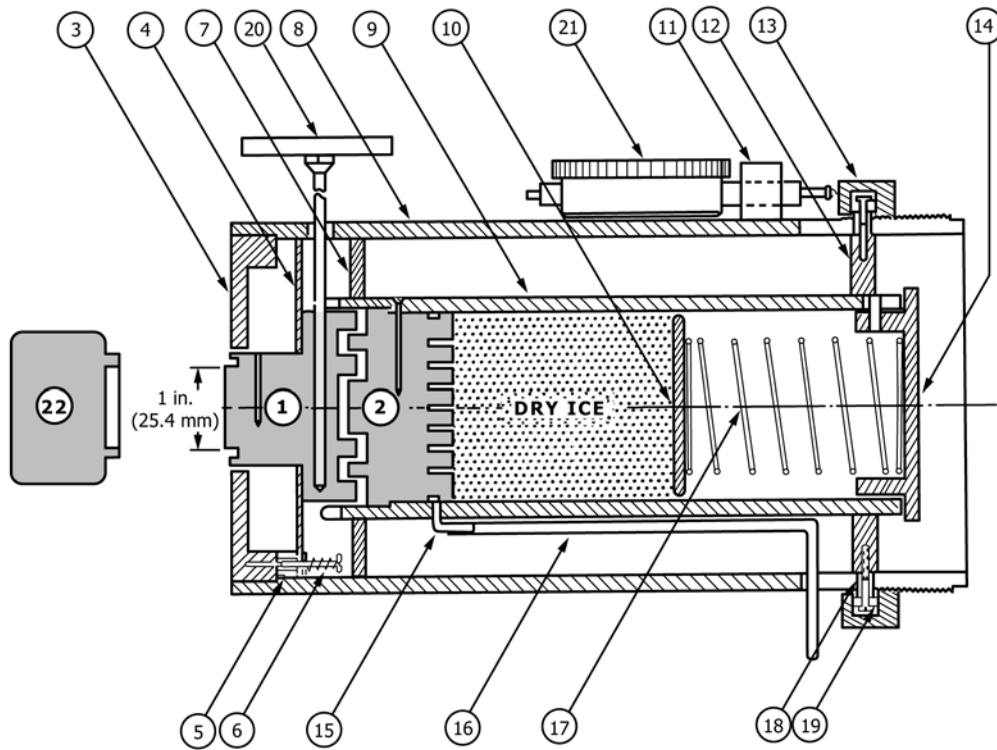

Part No.	Nomenclature	Part No.	Nomenclature
1	front metal block	12	supporting ring, bottom of inner tube
2	rear metal block	13	control ring
3	top cover	14	cover lid, inner tube
4	supporting plate, front metal block	15	elbow
5	spacer	16	tube, nylon
6	spring front metal block	17	main spring
7	supporting plate, top of inner tube	18	spacer
8	outer tube	19	bearing
9	inner tube	20	bimetallic dial thermometer
10	disk, dry ice pushing	21	dial indicator
11	clamp, dial gage	22	heat source block

FIG. 1 Schematic Diagram of Frost/Dew-Point Apparatus

5. Significance and Use

5.1 This test method is suitable for use under actual or simulated in-service conditions; that is, one side of the unit is exposed to room temperature, while the other side is exposed to natural or simulated weather conditions. Where the glazing conditions and the 24 h history are different or changed from previous conditions, the frost/dew point may not be comparable to a previous measurement.

5.2 This test method is applicable for the uncoated or unfilmed clear (transparent) glass lite of sealed insulating glass units. If this apparatus is used with coated or filmed glass lite, the coating or film on the surface of glass lite may be damaged.

5.3 This test method may require minor modifications to keep the measuring surface of the frost/dew-point apparatus in contact with the glass if the insulating glass unit is not in the true vertical position.

6. Apparatus

6.1 *Test Apparatus*⁴ (see Fig. 1); consisting of upper and lower cylindrical metal blocks with a thermocouple, bimetallic thermometer, or other suitable temperature sensors being inserted in the upper block; a control ring; and an insulated containment cylinder fitted with a retainer spring assembly. The two metal blocks are separated by a small air gap, the distance of which can be regulated by the control ring. The exposed flat circular surface of the upper block is 1 in. (25 mm) in diameter, has a ground or lapped finish, and when placed in

⁴ The sole source of supply of the apparatus known to the committee at this time is Dennis Industries, 20032 Waynegarden Court, Germantown, MD 20874, <http://www.dennisind.com>. If you are aware of alternative suppliers, please provide this information to ASTM International Headquarters. Your comments will receive careful consideration at a meeting of the responsible technical committee,¹ which you may attend.

contact with the glass test specimen, forms the frost/dew point measuring surface. The lower block is chilled by a dry ice pack kept in contact with it by the retainer spring assembly, maintaining it at a temperature near to that of sublimating dry ice ($-109\text{ }^{\circ}\text{F}$ ($-78\text{ }^{\circ}\text{C}$)). Because the solid metal blocks are highly conductive, the temperature of each is virtually uniform. Use of the control ring adjusts the air gap distance between the two blocks to give the desired thermal resistance across the air gap. The circular measuring surface of the upper block is thus readily adjusted to the desired temperature while in contact with the test specimen. The circular measuring surface diameter specified is suitable for frost/dew point measurement of glass up to $\frac{1}{4}$ in. (6.0 mm) thick.

6.1.1 *Upper and Lower Blocks*, aluminum alloy that may be anodized, conforming to the dimensions shown in Fig. 1. Other parts of the apparatus may be fabricated from any appropriate materials.

6.1.2 *Calibrated Temperature-Measuring Device*; such as a thermocouple, thermistor, or bimetallic thermometer; having a suitable range graduated in $2\text{ }^{\circ}\text{F}$ ($1\text{ }^{\circ}\text{C}$) or smaller units; and an accuracy of $\pm 1\text{ }^{\circ}\text{F}$ ($\pm 0.5\text{ }^{\circ}\text{C}$) over the full scale. A suggested calibration of the bimetallic thermometer is described in Appendix X1.

6.1.3 The size of the temperature measuring probe shall match the bore size drilled into the aluminum head in order to ensure proper temperature measurements.

6.2 *Vertical Attachment Fixture*⁴ (see Fig. 2), consisting of a twin-grip vacuum cup holder, two parallel guide rods, two spring posts, and two clamping springs. The vacuum cup is made of rubber. When the vertical attachment fixture is placed on the surface of clean glass and the vacuum hand lever is pushed down, the vertical attachment fixture becomes firmly attached to the glass surface. Other equivalent attachment fixtures may be used.

6.3 *Glass Thickness Gage* (see Fig. 3).

7. Test Unit

7.1 The sealed insulating glass unit to be tested should have a clear glass lite (see 5.2) in contact with the measuring side of the test apparatus and shall be positioned vertically.

8. Conditioning

8.1 Condition the unit to be tested at room temperature on both unit sides by exposing to a temperature of $75\text{ }^{\circ}\text{F} \pm 5\text{ }^{\circ}\text{F}$ ($24\text{ }^{\circ}\text{C} \pm 3\text{ }^{\circ}\text{C}$) for not less than 24 h prior to the testing.

8.2 Condition the unit to be tested under simulated in-service conditions by exposing to temperatures within $\pm 5\text{ }^{\circ}\text{F}$ ($\pm 3\text{ }^{\circ}\text{C}$) of the desired simulated conditions for not less than 24 h prior to testing.

8.3 For the unit to be tested under actual in-service conditions, record or obtain the ambient temperatures of both

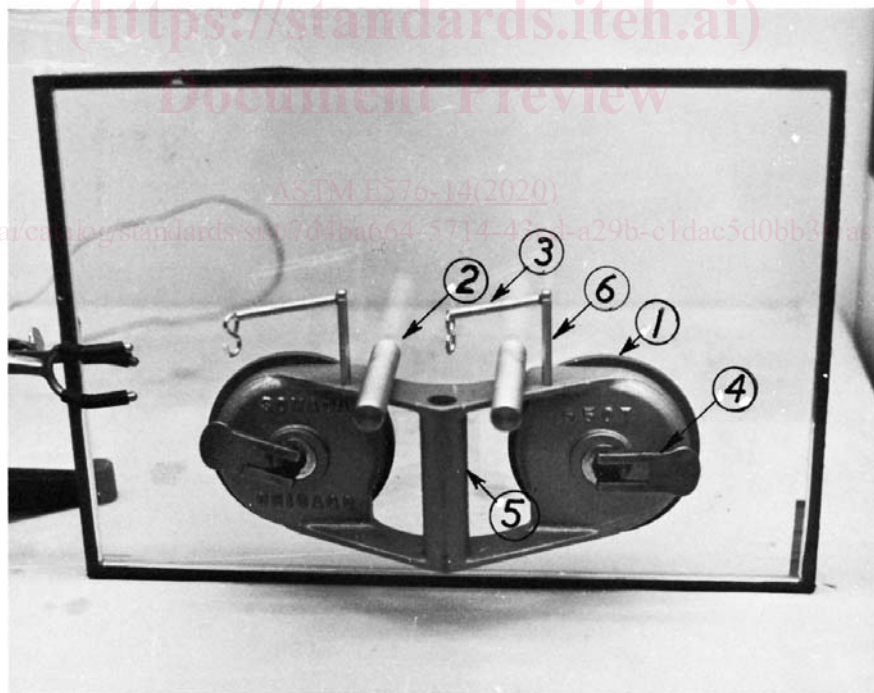

Part No.	Parts List	Nomenclature
1		rubber vacuum cup
2		guide rod
3		clamping spring
4		vacuum hand lever
5		hand grip
6		spring post

FIG. 2 Vertical Attachment

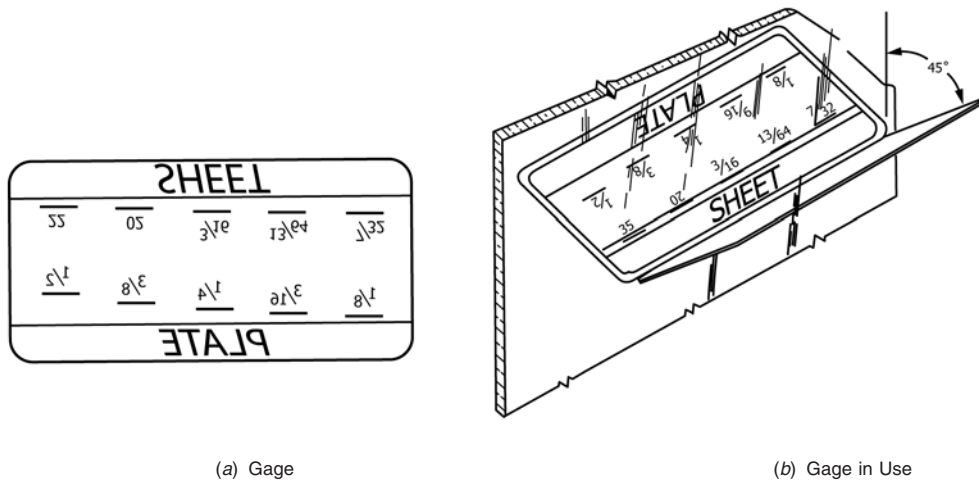

(a) Gage

(b) Gage in Use

FIG. 3 Glass Thickness Gage

sides of the unit at the start and end of a particular measuring period, and the 24 h temperature history prior to testing.

NOTE 1—At the present time, there is insufficient information to compare the measured frost/dew point of the unit from the reported temperature history to that implied in-service level of the unit. However, the temperature history will provide a valuable basis for evaluating the in-service level and life of the unit in the future.

9. Procedure

9.1 Preparation of Frost/Dew-Point Apparatus:

9.1.1 Disassemble the apparatus by removing the dry ice container and retainer spring assembly. Carefully clean the measuring surface with a soft cloth or paper. Do not scratch the measuring surface. Wipe and clean the apparatus thoroughly if any moisture has condensed on the surfaces and walls.

9.1.2 Assemble the dry ice container and turn the control ring so that the air gap distance between front and rear metal blocks is about 0.5 in. (13 mm). Invert the apparatus onto a soft cloth or a suitable mounting bracket.

9.1.3 Spray alcohol or acetone (**Warning**—Both alcohol and acetone are flammable.) on the fin of the dry ice container to ensure good contact with the dry ice. Compactly charge the container with the crushed or pulverized dry ice up to the “full” mark. Compress the dry ice with the spring assembly and lock the cover lid.

9.1.4 Turn the apparatus to an upright position. Allow sufficient time for the temperature of the rear metal block to approach near that of the dry ice temperature.

9.2 Recharging of Frost/Dew-Point Apparatus—During the test procedure, replenish the supply of dry ice whenever it becomes depleted by inverting the apparatus onto a soft cloth, opening the cover lid, taking out the retainer spring assembly, and repeating steps 9.1.3 and 9.1.4.

9.3 Determination of Frost State or No-Frost State:

9.3.1 Charge the frost/dew-point apparatus with dry ice as described in 9.1 or 9.2.

9.3.2 Measure the thickness of glass in the measuring side as follows:

9.3.2.1 Place the long side of the glass thickness gage (see Fig. 3) against the glass pane at a 45° angle.

9.3.2.2 Observe the reflection in the glass.

9.3.2.3 Note where the long line superimposes the short line.

9.3.2.4 Read the minimum thickness of the glass above.

9.3.3 Place the frost/dew-point apparatus on top of the guide rods of the vertical attachment fixture, facing the measuring surface of the frost/dew-point apparatus toward the rubber vacuum cup, and slide both guide fins of the frost/dew-point apparatus in between the guide rods from the rear end.

9.3.4 Hook each clamping spring to the hooks of the frost/dew-point apparatus.

9.3.5 Clean the exterior glass surface where the frost/dew-point apparatus and the vertical attachment fixtures are to be placed. Measure the frost/dew point within an area at least 10 in. (250 mm) away from the spacer or at the center of the unit. Examine the interior air space glass surface in the region, where dew or frost is to be deposited, to be aware of any dirt or other foreign particles that might be mistaken for frost. However, a small foreign particle on the interior air space glass surface may be helpful in focusing on the surface where the frost is to be deposited. Avoid the area where sunlight strikes directly on the unit or shade it from direct sunlight.

9.3.6 Release both vacuum hand levers of the vertical attachment fixture.

9.3.7 Due to the changes in the cold plate design, the use of the aluminized polyester film is no longer a requirement. However, it is still recommended in order to ensure a pristine viewing surface. If the reflective film is used then use the following procedure:

9.3.8 Clean the surfaces of the rubber vacuum cups, and the measuring surface and front surface of the frost/dew-point apparatus. If there are any water vapor or frost deposits on the measuring surface of the frost/dew-point apparatus, clean the measuring surface by wetting with alcohol (**Warning**—Alcohol is flammable.). If the measuring surface is heavily scratched, the front metal block should be replaced or repaired.

If the dew or frost deposit can be checked from the other side of the unit as described in 9.3.16, a piece of silver-colored aluminized polyester film with a highly reflective surface, not thicker than 0.003 in. (0.08 mm), and 1 in. (25 mm) in diameter, or 1 in. by 1 in. (25 mm by 25 mm) can be placed on the measuring surface by wetting both surfaces with alcohol.

9.3.9 To provide better thermal contact, wet the measuring surface of the frost/dew-point apparatus and exterior glass surface where it is to be contacted with alcohol (**Warning**—See 9.3.8).

9.3.10 Hold the hand grip of the vertical attachment fixture with one hand in a level position. Contact the measuring surface against the wetted glass surface and push the vertical attachment so that both rubber vacuum cups touch flatly against the glass surface (see Fig. 4).

9.3.11 Slowly flip the vacuum hand levers to a locking position so that the vertical attachment fixture is held firmly against the glass surface of the unit. If a vacuum cup does not hold the vacuum properly, release the vacuum hand lever and flip it again while applying a little more force. Make sure that the measuring surface and front surface of the frost/dew-point apparatus are flush with the glass surface. If it is not flush with the glass surface, adjust it by either increasing the tension of the clamping springs or adjusting the guide rod. If needed,

shim the guide rod. (**Warning**—Take care that the vertical attachment fixture does not fall off during the measurement.)

9.3.12 Wipe off the excessive alcohol running down the glass surface from the measuring surface before it reaches the glazing materials.

9.3.13 Slowly reduce the air gap distance between front and rear metal blocks by turning the control ring while watching the temperature of the front metal block.

9.3.14 Bring the temperature of the front metal block to the temperature to be checked for frost and stabilize it by fine adjustment of the control ring. Temperature fluctuation should not exceed ± 2 °F (± 1 °C).

9.3.15 Maintain the stabilized temperature for a minimum time duration as follows:

Glass Thickness Designation, in. (mm)	Stabilized Temperature—Duration, minimum, min
1/8 (2.5)	3
1/16 (3.0)	3
3/16 (5.0)	4
1/4 (6.0)	5

NOTE 2—See Specification C1036.

9.3.16 If the other side of the unit is accessible, clean the exterior glass surface and examine the interior air space glass surface in contact with the measuring surface. Illuminate the interior air space glass surface with a flashlight for better detection of frost deposit, if needed. If the other side of the unit is not accessible, unhook the clamping spring and slide out the frost/dew-point apparatus far enough to examine the interior air space glass surface. Then, quickly examine the interior air space glass surface for frost deposit. If the frost forms or water vapor condenses on the exterior glass surface where the measuring surface is contacted, wet the exterior glass surface with a small amount of alcohol.

9.3.17 If a clearly visible frost deposit appears on the interior air space glass surface during or after the temperature stabilization period, the frost/dew point of the unit is above this stabilized temperature (frost state) (see Fig. 5 for frost formation). If the frost deposit is so small and faint that it cannot be distinguished from the dirt or other foreign particles, lower the temperature of the measuring surface by 2 °F (1 °C) and hold this value for a duration given in 9.3.15. Reexamine the suspected particles. If the deposit is frost, its size or population will grow or get heavier.

9.3.18 If the frost deposit does not appear after the temperature stabilization period, the frost/dew point of the unit is below this stabilized temperature (no frost state).

9.3.19 To check at another temperature, repeat the test procedure described in 9.3.8 – 9.3.18 for the temperature desired. Whenever the measuring surface is detached from the glass surface, wet both surfaces with alcohol. If the alcohol has evaporated during the test, rewet the contact surface between the measuring surface and exterior glass surface.

9.4 Determination of Approximate Frost/Dew-Point Range:

9.4.1 Perform a series of measurements as described in 9.3 at successively lower temperatures until frost state is proven. Temperature intervals of 20 °F (10 °C) are preferable: for example, 20 °F (–10 °C), 0 °F (–20 °C), –20 °F (–30 °C), –40 °F (–40 °C), –60 °F (–50 °C), and –80 °F (–60 °C). Other temperature levels can be checked as desired. The frost/dew



FIG. 4 Vertical Attachment Fixture and Frost/Dew-Point Apparatus in Use

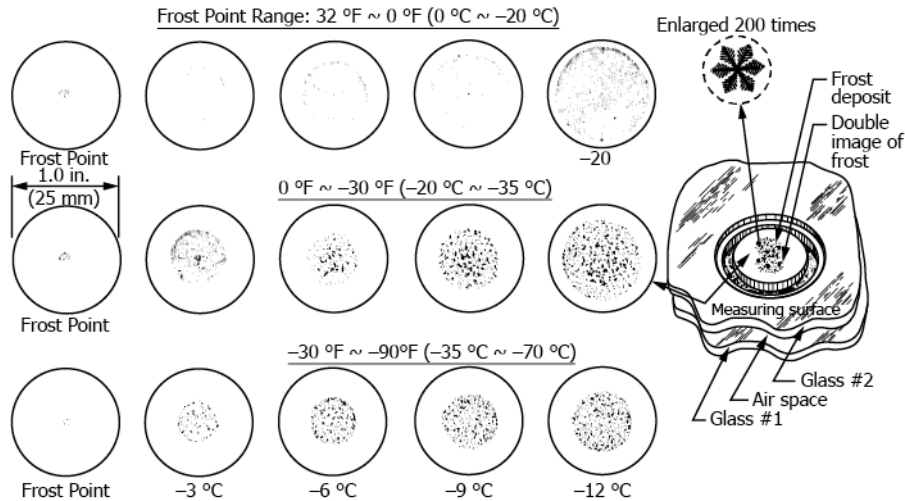

NOTE 1—Number -X means X °C below frost/dew point.
 NOTE 2—Size of frost deposit varies with the thickness of glass.

FIG. 5 References of Frost Deposit at a Glass Thickness of 3/16 in. (5.0 mm)

point will be between the temperature at which frost appeared and the next higher temperature.

9.4.2 When the frost/dew-point range can be predicted by experience (previously measured unit, and so forth), only the temperatures bracketing the predicted frost/dew point need be checked.

9.4.3 Estimate the frost/dew point of the unit within the temperature range between frost and no frost found in 9.4.1 by comparing the frost at the lower temperature limit (frost state) with the reference photograph (see Fig. 5) of similar temperature range.

9.5 Final Measurement of Frost/Dew Point:

9.5.1 Perform a series of frost, no-frost-state measurements described in 9.4 starting at several degrees Celsius above the estimated frost/dew point. Lower the temperature by intervals of less than 3 °F (2 °C) (preferably 2 °F (1 °C)). If frost appears at the first starting temperature, reestimate the frost/dew point using Fig. 5 and repeat the test.

9.5.2 The frost/dew point is the temperature at which visible frost first appears, or between this temperature and the next higher temperature that was checked.

9.5.3 Record the frost/dew point as the temperature of the front metal block when the visible frost first appears.

9.5.4 For repeated measurements of frost/dew point on the same unit, allow the frost to evaporate completely, or choose another spot at least 50 mm (2 in.) away from the previous measuring spot. The heat source block (see Fig. 1, Part 22) may be warmed and placed in momentary contact with the front metal block to raise its temperature before proceeding with a repeated measurement.

9.5.5 To remove the vertical attachment fixture and the frost/dew-point apparatus from the glass surface, hold the hand grip of the vertical attachment with one hand and release both vacuum hand levers. Remove the vertical attachment fixture with the frost/dew-point apparatus from the glass surface.

10. Visual Inspection

10.1 Clean the accessible exterior glass surface of the unit.

10.2 Examine both interior air space glass surfaces of the unit for clarity of vision under either normal daylight condition or proper illumination suitable for observing the following:

- 10.2.1 Frost deposit.
- 10.2.2 Chemical deposit.
- 10.2.3 Permanent fogging.
- 10.2.4 Scummed and stained interior glass surface or cloudy air space.
- 10.2.5 Deposits of Foreign Materials—Describe and report the presence of any of these items (see Fig. 6).

11. Report

- 11.1 Report the following information:
 - 11.1.1 Description of the Sealed Insulating Glass Unit Tested:
 - 11.1.1.1 Size of the unit (width by height, spacer to spacer).
 - 11.1.1.2 Thickness of glass in the measured side of the unit, thickness of glass in the other side of the unit, and thickness of airspace(s) if possible.
 - 11.1.1.3 Type of unit (clear, reflective, tinted, and so forth).
 - 11.1.1.4 Year of manufacture, if known (usually manufacturing year is stamped on the spacer).
 - 11.1.1.5 Glazing materials, if known.
 - 11.1.1.6 Sealant type, if known.
 - 11.1.1.7 Desiccant type and quantity, if known.
 - 11.1.1.8 Cross-section drawing of the unit, if known.
 - 11.1.1.9 Total number of units in the building.
 - 11.1.2 Location of the Unit—Description of the exact location and identification of the unit, such as:
 - 11.1.2.1 Name of the building.
 - 11.1.2.2 Address of the building.
 - 11.1.2.3 Floor and room number.
 - 11.1.2.4 Placement of the unit (south, north, east, west, and so forth).
 - 11.1.2.5 Sketch of the location of the unit so that other persons can easily identify the unit in the future.
 - 11.1.3 Month and year of installation of the unit.
 - 11.1.4 Time, date, and year of testing.

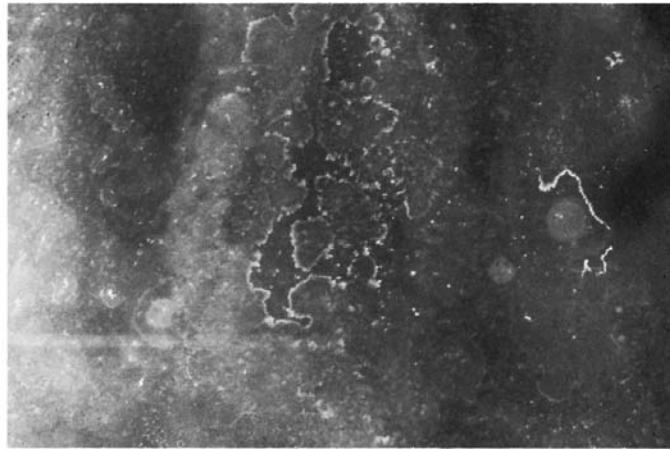

(a) Chemical Deposit (Close-Up View)



(b) Scummed and Stained Interior Glass Surface

FIG. 6 Visually Failed Units

11.1.5 Frost/dew point, and indication of which side of the unit was measured.

11.1.6 *In-Service Conditions When Testing:*

11.1.6.1 Ambient temperature of interior (indoor) side of the unit.

11.1.6.2 Ambient temperature of exterior (outdoor) side of the unit.

11.1.6.3 Sunlight condition incident on the unit.

11.1.6.4 Temperature history at 1 h intervals of conditions listed in 11.1.6.1 and 11.1.6.2 for 24 h prior to testing. (Check with nearest weather station or local newspaper, and so forth).

11.1.7 *Purpose of the Unit:*

11.1.7.1 *Window*—Picture, curtain wall, double hung, and so forth.

11.1.7.2 *Door*—Sliding, swing, and so forth.

11.1.7.3 *Others*—Description.

11.1.8 *Visual Characteristics*—If vision-obstructing deposits are observed (see 10.2) state the detailed facts.

12. Precision and Bias

12.1 The precision and bias of this test method was determined after assembling various laboratory personnel in one common laboratory with their respective test equipment. All tests were performed on the same set of specially prepared test specimens.