



Designation: ~~D2603~~—~~19~~ D2603 – 20

Standard Test Method for Sonic Shear Stability of Polymer-Containing Oils¹

This standard is issued under the fixed designation D2603; the number immediately following the designation indicates the year of original adoption or, in the case of revision, the year of last revision. A number in parentheses indicates the year of last reappraisal. A superscript epsilon (ϵ) indicates an editorial change since the last revision or reappraisal.

This standard has been approved for use by agencies of the U.S. Department of Defense.

1. Scope*

1.1 This test method covers the evaluation of the shear stability of an oil containing polymer in terms of the permanent loss in viscosity that results from irradiating a sample of the oil in a sonic oscillator. This test method can be useful in predicting the continuity of this property in an oil where no change is made in the base stock or the polymer. It is not intended that this test method serve to predict the performance of polymer-containing oils in service.

1.2 Evidence has been presented that correlation between the shear degradation results obtained by means of sonic oscillation and those obtained in mechanical devices can be poor. This is especially true in the case of automotive engines. Further evidence indicates that the sonic technique may rate different families of polymers in a different order than mechanical devices.^{2,3}

1.3 Because of these limitations, the committee under whose jurisdiction this test method falls has developed alternative shear test methods using a diesel injector nozzle, Test Methods [D5275](#), [D6278](#), and [D7109](#). While those test methods have found some utility in the evaluation of crankcase oils, the stress imparted to the sample has been found to be insufficient to shear polymers of the shear-resistant type found in aircraft hydraulic fluids.

1.4 This test method is used for polymeric additive specifications, especially in the hydraulic fluid market.

1.5 The values stated in SI units are to be regarded as standard. The values given in parentheses after SI units are provided for information only and are not considered standard.

1.6 *This standard does not purport to address all of the safety concerns, if any, associated with its use. It is the responsibility of the user of this standard to establish appropriate safety, health, and environmental practices and determine the applicability of regulatory limitations prior to use.*

1.7 *This international standard was developed in accordance with internationally recognized principles on standardization established in the Decision on Principles for the Development of International Standards, Guides and Recommendations issued by the World Trade Organization Technical Barriers to Trade (TBT) Committee.*

2. Referenced Documents

2.1 *ASTM Standards:*⁴

[D445 Test Method for Kinematic Viscosity of Transparent and Opaque Liquids \(and Calculation of Dynamic Viscosity\)](#)

[D5275 Test Method for Fuel Injector Shear Stability Test \(FISST\) for Polymer Containing Fluids](#)

[D6022 Practice for Calculation of Permanent Shear Stability Index](#)

[D6278 Test Method for Shear Stability of Polymer Containing Fluids Using a European Diesel Injector Apparatus](#)

[D7042 Test Method for Dynamic Viscosity and Density of Liquids by Stabinger Viscometer \(and the Calculation of Kinematic Viscosity\)](#)

[D7109 Test Method for Shear Stability of Polymer-Containing Fluids Using a European Diesel Injector Apparatus at 30 Cycles and 90 Cycles](#)

¹ This test method is under the jurisdiction of ASTM Committee [D02](#) on Petroleum Products, Liquid Fuels, and Lubricants and is the direct responsibility of Subcommittee [D02.07](#) on Flow Properties.

Current edition approved ~~June 1, 2019~~ May 1, 2020. Published ~~July 2019~~ May 2020. Originally approved in 1967. Last previous edition approved in ~~2013~~ 2019 as ~~D2603-01 (2013)~~ [D2603-19](#). DOI: ~~10.1520/D2603-19~~ [10.1520/D2603-20](#).

² *The Effects of Polymer Degradation on Flow Properties of Fluids and Lubricants*, ASTM STP 382, ASTM, 1965. Available from ASTM Headquarters, 100 Barr Harbor Drive, West Conshohocken, PA 19428, [www.astm.org](#).

³ *Shear Stability of Multigrade Crankcase Oil*, ASTM DS 49, ASTM, 1973. Available from ASTM Headquarters, 100 Barr Harbor Drive, West Conshohocken, PA 19428, [www.astm.org](#).

⁴ For referenced ASTM standards, visit the ASTM website, [www.astm.org](#), or contact ASTM Customer Service at [service@astm.org](#). For *Annual Book of ASTM Standards* volume information, refer to the standard's Document Summary page on the ASTM website.

*A Summary of Changes section appears at the end of this standard

3. Summary of Test Method

3.1 A convenient volume of polymer-containing oil is irradiated in a sonic oscillator for a period of time and the changes in viscosity are determined by Test Method [D445](#) and [D7042](#). Standard reference fluids containing either a readily sheared or shear-resistant polymer are run frequently to ensure that the equipment imparts a controlled amount of sonic energy to the sample.

NOTE 1—The conditions to obtain the data for the precision statement were a 30 mL sample, 10 min, and at 0 °C.

4. Significance and Use

4.1 This test method permits the evaluation of shear stability with minimum interference from thermal and oxidative factors which may be present in some applications. Within the limitations expressed in the scope of this test method, it has been successfully applied to hydraulic fluids, transmission fluids, tractor fluids, and other fluids of similar applications. It has been found applicable to fluids containing both readily sheared and shear-resistant polymers. Correlation with performance in the case of automotive engine applications has, to date, not been established.

5. Apparatus

5.1 *Sonic Shear Unit*, fixed frequency oscillator and sonic horn.

5.2 *Auxiliary Equipment*—To facilitate uniform performance, the following auxiliary equipment is recommended:

5.2.1 *Cooling Bath or Ice Bath*—To maintain a desired temperature such as 0 °C.

5.2.2 *Griffin 50 mL Beaker, borosilicate glass*.

5.2.3 *Sonic-Insulated Box*—To enclose the sonic horn to reduce the ambient noise level produced by the sonic shear unit.

5.3 *Viscometer*—Any viscometer and bath meeting the requirements ~~of~~ for determining kinematic viscosity: Test Method [D445](#) or [D7042](#). Whichever method is chosen, that same method must be used for the before and after samples as well as the calibration samples.

6. Reference Fluids

6.1 The primary reference fluid is ASTM Reference Fluid A,⁵ a petroleum oil containing a polymer capable of being broken down by turbulence at high rates of shear. This oil has the following typical properties:

	Petroleum Base	Reference Fluid A
Viscosity at 100 °C, mm ² /s (cSt)	5.4	10.8
Viscosity at 100 °C, mm ² /s (cSt)	5.4	10.8
Viscosity at 40 °C, mm ² /s (cSt)	32	58

6.2 A second reference fluid is ASTM Reference Fluid B,⁵ a petroleum oil containing a polymer capable of being broken down by turbulence at high rates of shear. This oil has a viscosity of about 13.6 mm²/s (cSt) at 40 °C.

7. Calibration of Apparatus

7.1 The reference fluid provides a practical way to define the performance (severity level) of a sonic oscillator unit so that satisfactory comparison can be made between tests run on different days in the same unit and between tests run with different units.

7.2 The decrease in viscosity observed for a given polymer-containing oil on irradiation in an oscillator unit depends on a number of factors; these include sample volume, irradiation time, and oscillator power setting. These parameters can be varied in order to increase or decrease severity of test exposure. Tuning of the oscillator-horn combination is also required in order to assure efficiency of energy coupling between the two units. The procedure described in [7.3](#) and [7.4](#) is recommended for establishing a reproducible performance level for a given unit.

7.3 Introduce 30 mL of a reference fluid into the 50 mL Griffin beaker. Immerse the beaker in ice water or in another constant temperature bath until sample fluid level is below the liquid level in the bath. The beaker shall be positioned in a vertical position in the bath. Secure beaker in this position and condition the sample for 10 min before commencing exposure. Immerse the sonic horn into sample fluid until tip is exactly 10 mm below surface of fluid (see [Fig. 1](#)). The horn shall be positioned in a vertical position in the fluid and centered in the beaker (a weighted ringstand may be used to support the horn in this position). Irradiate the fluid for 10 min at a preselected power setting. Experience has shown that with some instruments this may require readjustment of the controls during irradiation to maintain the preselected power. Determine the decrease in reference fluid viscosity. Repeat as necessary to determine the proper power setting to produce a viscosity change at 40 °C of 15.0 % (± 0.5 %). Use this power setting for subsequent test runs. Daily recalibration of the apparatus is required because the power setting required to produce a stated

⁵ The sole source of supply of the reference fluid known to the committee at this time is Evonik Oil Additives USA, Inc., 723 Electronic Dr., Horsham, PA 19044-2228. If you are aware of alternative suppliers, please provide this information to ASTM International Headquarters. Your comments will receive careful consideration at a meeting of the responsible technical committee,¹ which you may attend.

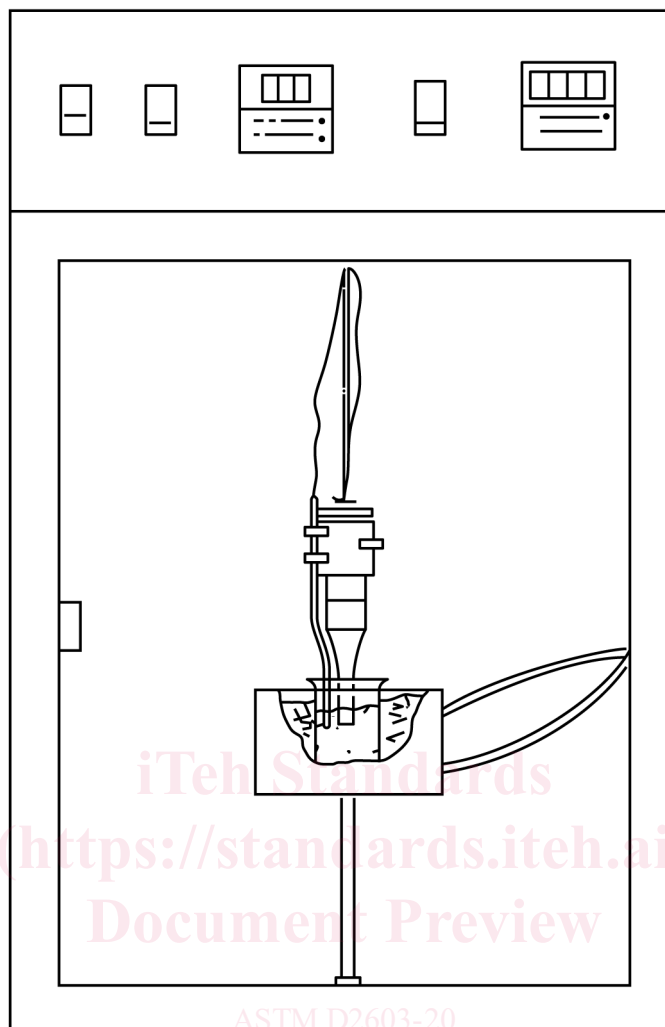

FIG. 1 Schematic of Sonic Probe Type Apparatus, Support Systems, Cabinet and Power Supply

viscosity loss will probably vary from day to day. Experience with a given apparatus set will determine whether more frequent calibration is required. Calibration in this manner will assure that repeatable severity levels are established for any predetermined set of test parameters.

7.4 This procedure can be used to establish severity levels appropriate for the requirements of a variety of applications. Once the conditions for a given severity level have been established, it is possible to compare the shear stability of fluids at one or more irradiation times. If calibration at conditions other than 15.0 % \pm 0.5 % decrease of reference fluid viscosity at 40 °C are employed, that fact shall be included in the test report.

NOTE 2—For interlaboratory comparisons, the laboratories should define a common severity level in terms of a specified viscosity loss of the reference fluid occurring in a given irradiation time with a given volume of sample. For example, “the reference fluid should undergo a viscosity loss of 15 % when a 30 mL sample is treated for 10 min.”

Alternatively, two or more laboratories can define equivalent operating conditions by a curve of percent viscosity loss of a reference fluid as a function of irradiation time. Power setting and sample size are varied until each laboratory finds a combination that satisfies two or more points on the reference curve. This procedure provides a comparison of the shear stability of an unknown fluid with that of the reference fluid over a range of irradiation times.

8. Procedure

8.1 Clean the sonic horn with a suitable solvent and calibrate the apparatus as described in 7.3 and 7.4. Introduce 30 mL of the sample into a clean 50 mL Griffin beaker and immerse in the constant temperature bath at the desired temperature (0 °C unless otherwise specified). The beaker must be in a vertical position. Allow the sample to equilibrate for 10 min. Immerse the sonic horn in the fluid as described in 7.3. Irradiate the sample at exactly the same energy level and for the same time as determined in 7.3 and 7.4. Upon completion of irradiation, remove the sample and clean the sonic horn with a suitable solvent.

8.2 Determine the viscosity of the sample by Test Method D445 or D7042 before and after irradiation.