



Designation: D36/D36M – 14 (Reapproved 2020)

# Standard Test Method for Softening Point of Bitumen (Ring-and-Ball Apparatus)<sup>1</sup>

This standard is issued under the fixed designation D36/D36M; the number immediately following the designation indicates the year of original adoption or, in the case of revision, the year of last revision. A number in parentheses indicates the year of last reapproval. A superscript epsilon ( $\epsilon$ ) indicates an editorial change since the last revision or reapproval.

## 1. Scope

1.1 This test method covers the determination of the softening point of bitumen in the range from 30 to 157 °C [86 to 315 °F] using the ring-and-ball apparatus immersed in distilled water [30 to 80 °C] or USP glycerin (above 80 to 157 °C).

1.2 The values stated in either SI units or inch-pound units are to be regarded separately as standard. The values stated in each system may not be exact equivalents; therefore, each system shall be used independently of the other. Combining values from the two systems may result in nonconformance with the standard.

1.3 *This standard does not purport to address all of the safety concerns, if any, associated with its use. It is the responsibility of the user of this standard to establish appropriate safety, health, and environmental practices and determine the applicability of regulatory limitations prior to use.*

1.4 *This international standard was developed in accordance with internationally recognized principles on standardization established in the Decision on Principles for the Development of International Standards, Guides and Recommendations issued by the World Trade Organization Technical Barriers to Trade (TBT) Committee.*

## 2. Referenced Documents

2.1 *ASTM Standards:*<sup>2</sup>

C670 Practice for Preparing Precision and Bias Statements for Test Methods for Construction Materials

D92 Test Method for Flash and Fire Points by Cleveland Open Cup Tester

D140/D140M Practice for Sampling Asphalt Materials

D3461 Test Method for Softening Point of Asphalt and Pitch (Mettler Cup-and-Ball Method)

E1 Specification for ASTM Liquid-in-Glass Thermometers

<sup>1</sup> This test method is under the jurisdiction of ASTM Committee D08 on Roofing and Waterproofing and is the direct responsibility of Subcommittee D08.03 on Surfacing and Bituminous Materials for Membrane Waterproofing and Built-up Roofing.

Current edition approved May 1, 2020. Published May 2020. Originally approved in 1962. Last previous edition approved in 2014 as D36 – 14. DOI: 10.1520/D0036\_D0036M-14R20.

<sup>2</sup> For referenced ASTM standards, visit the ASTM website, [www.astm.org](http://www.astm.org), or contact ASTM Customer Service at [service@astm.org](mailto:service@astm.org). For *Annual Book of ASTM Standards* volume information, refer to the standard's Document Summary page on the ASTM website.

E177 Practice for Use of the Terms Precision and Bias in ASTM Test Methods

E691 Practice for Conducting an Interlaboratory Study to Determine the Precision of a Test Method

## 3. Summary of Test Method

3.1 Two horizontal disks of bitumen, cast in shouldered brass rings, are heated at a controlled rate in a liquid bath while each supports a steel ball. The softening point is reported as the mean of the temperatures at which the two disks soften enough to allow each ball, enveloped in bitumen, to fall a distance of 25 mm [1.0 in.].

## 4. Significance and Use

4.1 Bitumens are viscoelastic materials without sharply defined melting points; they gradually become softer and less viscous as the temperature rises. For this reason, softening points must be determined by an arbitrary and closely defined method if results are to be reproducible.

4.2 The softening point is useful in the classification of bitumens, as one element in establishing the uniformity of shipments or sources of supply, and is indicative of the tendency of the material to flow at elevated temperatures encountered in service.

## 5. Apparatus

5.1 *Rings*—Two square-shouldered brass rings conforming to the dimensions shown in Fig. 1(a).

5.2 *Pouring Plate*—A flat, smooth, brass plate approximately 50 by 75 mm [2 by 3 in.].

5.3 *Balls*—Two steel balls, 9.5 mm [ $\frac{3}{8}$  in.] in diameter, each having a mass of  $3.50 \pm 0.05$  g.

5.4 *Ball-Centering Guides*—Two brass guides for centering the steel balls, one for each ring, conforming to the general shape and dimensions shown in Fig. 1(b).

5.5 *Bath*—A glass vessel, capable of being heated, not less than 85 mm in inside diameter and not less than 120 mm in depth from the bottom of the flare.

NOTE 1—An 800-mL, low-form Griffin beaker of heat-resistant glass meets this requirement.

5.6 *Ring Holder and Assembly*—A brass holder designed to support the two rings in a horizontal position, conforming to

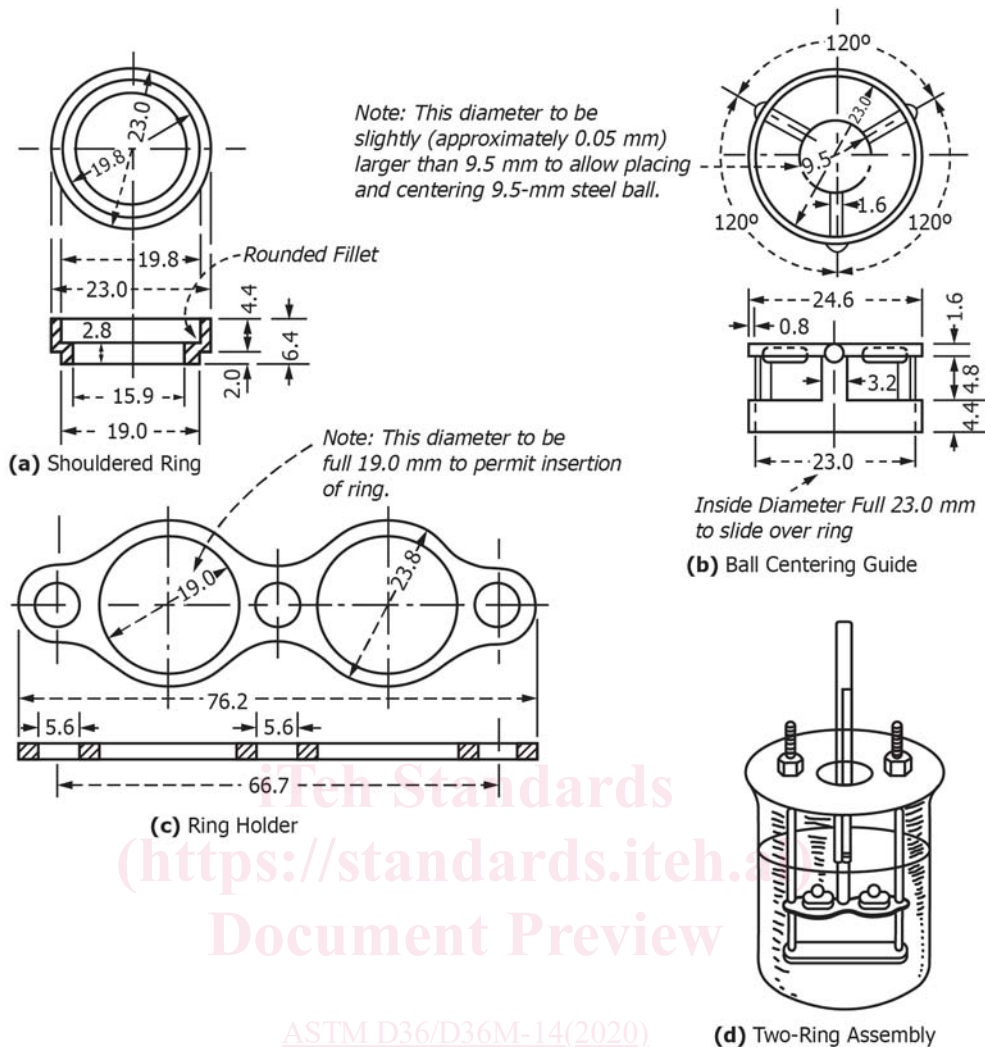

FIG. 1 Shouldered Ring, Ball-Centering Guide, Ring Holder, and Assembly of Apparatus Showing Two Rings

the shape and dimensions shown in Fig. 1(c), supported in the assembly illustrated in Fig. 1(d). The bottom of the shouldered rings in the ring holder shall be 25 mm [1.0 in.] above the upper surface of the bottom plate, and the lower surface of the bottom plate shall be  $16 \pm 3$  mm [ $5/8 \pm 1/8$  in.] from the bottom of the bath.

5.7 Thermometers:

5.7.1 An ASTM Low Softening Point Thermometer, having a range from  $-2$  to  $+80$  °C or 30 to 180 °F, and conforming to the requirements for Thermometer 15C or 15F as prescribed in Specification E1. As an alternative, any other thermometric device used shall be at least: (1) of equal accuracy to that of the thermometer specified in Specification E1, (2) capable of indicating temperature to within 1 °C [2 °F], and (3) stable to within 1 °C [2 °F] for the duration of the exposure.

5.7.2 An ASTM High Softening Point Thermometer, having a range from 30 to 200 °C or 85 to 392 °F, and conforming to the requirements for Thermometer 16C or 16F as prescribed in Specification E1. As an alternative, any other thermometric device used shall be at least: (1) of equal accuracy to that of the

thermometer specified in Specification E1, (2) capable of indicating temperature to within 1 °C [2 °F], and (3) stable to within 1 °C [2 °F] for the duration of the exposure.

5.7.3 The appropriate thermometer shall be suspended in the assembly as shown in Fig. 1(d) so that the bottom of the bulb is level with the bottom of the rings and within 13 mm [0.5 in.] of the rings, but not touching them or the ring holder. Substitution of other thermometers shall not be permitted. As an alternative, any other thermometric device used shall be at least: (1) of equal accuracy to that of the thermometer specified in Specification E1, (2) capable of indicating temperature to within 0.5 °C [1.0 °F], and (3) stable to within 0.5 °C [1.0 °F] for the duration of the exposure.

6. Reagents and Materials

6.1 Bath Liquids:

6.1.1 Freshly Boiled Distilled Water.

NOTE 2—The use of freshly boiled distilled water is essential to avoid trapping air bubbles on the surface of the specimen which may affect the results.

6.1.2 *USP Glycerin*. (**Warning**—Glycerin has a flash point of 160 °C [320 °F] in accordance with Test Method **D92**.)

#### 6.2 *Release Agents*:

6.2.1 To prevent adhesion of bitumen to the pouring plate when casting disks, the surface of the brass pouring plate may be thinly coated just before use with silicone oil or grease, a mixture of glycerin and dextrin, talc, or china clay. (**Warning**—Isolate silicones from other bituminous testing equipment and samples to avoid contamination, and wear disposable rubber gloves whenever handling silicones or apparatus coated with them. Silicone contamination can produce erroneous results in other tests such as those for penetration and flash point.)

### 7. Hazards

7.1 **Warning**—Mercury has been designated by EPA and many state agencies as a hazardous material that can cause central nervous system, kidney, and liver damage. Mercury, or its vapor, may be hazardous to health and corrosive to materials. Caution should be taken when handling mercury and mercury-containing products. See the applicable product Material Safety Data Sheet (MSDS) for details and EPA's website, <http://www.epa.gov/mercury/faq.htm>, for additional information. Users should be aware that selling mercury or mercury-containing products, or both, in your state may be prohibited by state law.

### 8. Sampling

8.1 Sample the material in accordance with Practice **D140/D140M**.

### 9. Test Specimens

9.1 Do not start unless it is planned to complete preparation and testing of all asphalt specimens within 6 h and all coal-tar pitch specimens within 4½ h. Heat the bitumen sample with care, stirring frequently to prevent local overheating, until it has become sufficiently fluid to pour (**Note 3**). Stir carefully to avoid incorporation of air bubbles in the sample.

**NOTE 3**—An electric hot plate having a minimum power to unit-surface-area ratio of 37 kW/m<sup>2</sup> has been found satisfactory for this purpose.

9.1.1 Take no more than 2 h to heat an asphalt sample to its pouring temperature; in no case shall this be more than 110 °C [200 °F] above the expected softening point of the asphalt.

9.1.2 Take no more than 30 min to heat a coal-tar pitch sample to its pouring temperature; in no case shall this be more than 55 °C [100 °F] above the expected softening point of the coal-tar pitch.

9.1.3 If the test must be repeated later, do not reheat this sample; use a fresh sample in a clean container to prepare new test specimens.

9.2 Heat the two brass rings (but not the pouring plate) to the approximate pouring temperature, and place them on the pouring plate treated with one of the release agents.

9.3 Pour a slight excess of the heated bitumen into each ring, and then allow the specimens to cool in ambient air for at least 30 min. For materials that are soft at room temperature,

cool the specimens for at least 30 min at an air temperature at least 10 °C [18 °F] below the expected softening point. From the time the specimen disks are poured, no more than 240 min shall elapse before completion of the test.

9.4 When the specimens have cooled, cut away the excess bitumen cleanly with a slightly heated knife or spatula, so that each disk is flush and level with the top of its ring.

### 10. Procedure

10.1 Select one of the following bath liquids and thermometers appropriate for the expected softening point:

10.1.1 Freshly boiled distilled water for softening points between 30 and 80 °C [86 and 176 °F]; use Thermometer 15C or 15F. The starting bath temperature shall be 5 ± 1 °C [41 ± 2 °F].

10.1.2 USP glycerin for softening points above 80 °C [176 °F] and up to 157 °C [315 °F]; use Thermometer 16C or 16F or the thermometric device. The starting bath temperature shall be no higher than 30 ± 1 °C [86 ± 2 °F].

10.1.3 For referee purposes, all softening points up to 80 °C [176 °F] shall be determined in a water bath and all softening points above 80 °C [176 °F] shall be determined in a glycerin bath or as agreed to by seller and buyer.

10.2 Assemble the apparatus in the laboratory hood with the specimen rings, ball-centering guides, and thermometer in position, and fill the bath so that the liquid depth will be 105 ± 3 mm [4¼ ± ⅛ in.] with the apparatus in place. Using forceps, place the two steel balls in the bottom of the bath for at least 5 min so they will reach the same starting temperature as the rest of the assembly.

10.3 Place the bath in ice water, if necessary, or gently heat to establish and maintain the proper starting bath temperature for 15 min with the apparatus in place. Take care not to contaminate the bath liquid.

10.4 Again using forceps, place a ball from the bottom of the bath in each ball-centering guide.

10.5 Heat the bath from below so that the temperature indicated by the thermometer rises at a uniform rate of 5 °C [9 °F]/min (**Note 4**). Protect the bath from drafts, using shields if necessary. Do not average the rate of temperature rise over the test period. The maximum permissible variation for any 1-min period after the first 3 min shall be ±0.5 °C [±1.0 °F]. Reject any test in which the rate of temperature rise does not fall within these limits.

**NOTE 4**—Rigid adherence to the prescribed heating rate is essential to reproducibility of results. Either a gas burner or electric heater may be used, but the latter must be of the low-lag, variable output type to maintain the prescribed rate of heating.

10.6 Record for each ring and ball the temperature indicated by the thermometer at the instant the bitumen surrounding the ball touches the bottom plate. Make no correction for the emergent stem of the thermometer. If the difference between the two temperatures exceeds 1 °C [2 °F], repeat the test.

### 11. Calculation

11.1 For a given bitumen specimen, the softening point determined in a water bath will be lower than that determined