



Designation: **D6766—20 D6766 – 20a**

Standard Test Method for Evaluation of Hydraulic Properties of Geosynthetic Clay Liners Permeated with Potentially Incompatible Aqueous Solutions¹

This standard is issued under the fixed designation D6766; the number immediately following the designation indicates the year of original adoption or, in the case of revision, the year of last revision. A number in parentheses indicates the year of last reappraisal. A superscript epsilon (ϵ) indicates an editorial change since the last revision or reappraisal.

1. Scope

1.1 This test method covers laboratory measurement of both flux and hydraulic conductivity (also referred to as *coefficient of permeability*) of geosynthetic clay liner (GCL) specimens permeated with chemical solutions and leachates utilizing a flexible wall permeameter. For test measurement of index hydraulic properties of geosynthetic clay liners, refer to Test Method [D5887/D5887M](#). For hydraulic conductivity compatibility of soils with aqueous chemical solutions and leachates, refer to Test Method [D7100](#).

1.2 This test method may be utilized with GCL specimens that have a hydraulic conductivity less than or equal to 1×10^{-5} m/s (1×10^{-3} cm/s).

1.3 This test method is applicable to GCL products having geotextile backing(s). It is not applicable to GCL products with geomembrane backing(s), geofilm backing(s), or polymer coating backing(s).

1.4 This test method allows the requester to evaluate the hydraulic properties of a GCL with site-specific or laboratory-prepared solution under different test conditions; thus, the test method also may be used to check performance or conformance, or both.

1.5 The values stated in SI units are to be regarded as the standard, unless other units are specifically given. By tradition in U.S. practice, hydraulic conductivity is reported in centimeters per second, although the common SI units for hydraulic conductivity are meters per second.

1.6 *This standard does not purport to address all of the safety concerns, if any, associated with its use. It is the responsibility of the user of this standard to establish appropriate safety, health, and environmental practices and determine the applicability of regulatory limitations prior to use.*

1.7 *This international standard was developed in accordance with internationally recognized principles on standardization established in the Decision on Principles for the Development of International Standards, Guides and Recommendations issued by the World Trade Organization Technical Barriers to Trade (TBT) Committee.*

2. Referenced Documents

2.1 ASTM Standards:²

[D653 Terminology Relating to Soil, Rock, and Contained Fluids](#)

[D854 Test Methods for Specific Gravity of Soil Solids by Water Pycnometer](#)

[D2216 Test Methods for Laboratory Determination of Water \(Moisture\) Content of Soil and Rock by Mass](#)

[D4439 Terminology for Geosynthetics](#)

[D4753 Guide for Evaluating, Selecting, and Specifying Balances and Standard Masses for Use in Soil, Rock, and Construction Materials Testing](#)

[D5887/D5887M Test Method for Measurement of Index Flux Through Saturated Geosynthetic Clay Liner Specimens Using a Flexible Wall Permeameter](#)

[D7100 Test Method for Hydraulic Conductivity Compatibility Testing of Soils with Aqueous Solutions](#)

[E145 Specification for Gravity-Convection and Forced-Ventilation Ovens](#)

¹ This test method is under the jurisdiction of ASTM Committee [D35](#) on Geosynthetics and is the direct responsibility of Subcommittee [D35.04](#) on Geosynthetic Clay Liners.

Current edition approved ~~Jan. 1, 2020~~ May 1, 2020. Published ~~January 2020~~ May 2020. Originally approved in 2002. Last previous edition approved in 2018 as ~~D6766—18~~ D6766 – 20. DOI: ~~10.1520/D6766-20~~ 10.1520/D6766-20A.

² For referenced ASTM standards, visit the ASTM website, www.astm.org, or contact ASTM Customer Service at service@astm.org. For *Annual Book of ASTM Standards* volume information, refer to the standard's Document Summary page on the ASTM website.

3. Terminology

3.1 Definitions:

3.1.1 *flux, n*—the rate of discharge of liquid under laminar flow conditions through a unit cross-sectional area of a GCL specimen at a standard temperature condition (22 ± 3 °C).

3.1.2 *geosynthetic clay liner (GCL), n*—a factory-manufactured geosynthetic hydraulic barrier consisting of clay supported by geotextiles, geomembranes, or a combination thereof, that are held together by needling, stitching, chemical adhesives, or other methods.

3.1.3 *hydraulic conductivity, k, n*—the rate of discharge of liquid under laminar flow conditions through a unit cross-sectional area of a GCL specimen under a unit hydraulic gradient and standard temperature conditions (22 ± 3 °C).

3.1.3.1 Discussion—

The term *coefficient of permeability* is often used instead of *hydraulic conductivity*, but *hydraulic conductivity* is used exclusively in this test method. A more complete discussion of the terminology associated with Darcy's law is given in the literature.³

3.1.4 *index test, n*—a test procedure that may contain bias, but may be used to establish comparable results with respect to the property of interest.

3.1.5 *pore volume of flow, n*—the cumulative quantity of flow into a test specimen divided by the volume of voids in the specimen.

3.2 For definitions of other terms used in this test method, see Terminologies [D653](#) and [D4439](#).

4. Significance and Use

4.1 This test method applies to one-dimensional, laminar flow of aqueous solutions, such as chemical solutions, landfill leachate, and contaminated water (from here on referred to as “test liquid”), through saturated/hydrated GCL specimen that is consolidated and permeated under a prescribed or requested set of conditions.

4.2 This test method assumes that Darcy's law is valid and that the hydraulic conductivity is essentially unaffected by hydraulic gradient. The validity of Darcy's law may be evaluated by measuring the hydraulic conductivity of the specimen at three different hydraulic gradients; if all measured values are similar (within about 25 %), then Darcy's law may be taken as valid. However, when the hydraulic gradient acting on a test specimen is changed, the state of stress will also change and, if the specimen is compressible, the volume of the specimen will change. Thus, some change in hydraulic conductivity may occur when the hydraulic gradient is altered, even in cases where Darcy's law is valid.

4.3 This test method provides tools for determining flux and hydraulic conductivity values for a given GCL under the following two different scenarios, which should be specified by the requester:

4.3.1 *Scenario 1 – Hydrated/Saturated with Water Prior to Contact with Test Liquid*—This scenario simulates the field conditions where the GCL is well hydrated with water prior to contact with actual test liquid. It should be noted that initial degree of saturation/hydration greatly affects the hydraulic properties of a GCL product. The test has two phases: (Phase 1) hydrate, saturate, consolidate, and permeate with water as Test Liquid 1, and (Phase 2) switch to permeation with test liquid as Test Liquid 2.

4.3.2 *Scenario 2 – Hydrated/Saturated with Test Liquid (Worst Case)*—This scenario simulates the field conditions where the GCL is in contact with test liquid prior to being fully hydrated with water. It should be noted that this scenario may result in higher flux and hydraulic conductivity values compared to Scenario 1, as chemicals present in test liquid may alter the hydration and hydraulic properties of a GCL product.

4.4 The apparatus used in this test method is commonly used to determine the hydraulic conductivity of soil specimens. However, flux values measured in this test are typically much lower than those commonly measured for most natural soils. It is essential that the leakage rate of the apparatus in this test be less than 10 % of the flux.

5. Apparatus

5.1 *Compatibility*—All parts in contact with the test liquid(s) shall be checked/verified for long-term compatibility. This can be established either based on the available information or by in-house testing.

5.2 *Hydraulic System*—Constant head (Method A), falling head (Methods B and C), or constant rate of flow (Method D) systems may be utilized provided they meet the criteria outlined as follows:

5.2.1 *Constant Head (Method A)*—The system must be capable of maintaining constant hydraulic pressures to within ± 5 % and shall include means to measure the hydraulic pressures to within the prescribed tolerance. In addition, the head loss across the test

³ Olson, R. E. and Daniel, D. E., “Measurement of the Hydraulic Conductivity of Fine-Grained Soils,” *Symposium on Permeability and Groundwater Contaminant Transport*, ASTM STP 746, ASTM International, 1981, pp. 18–64.

specimen must be held constant to within $\pm 5\%$ and shall be measured with the same accuracy or better. Pressures shall be measured by a pressure gage, electronic pressure transducer, or any other device of suitable accuracy.

5.2.2 Falling Head (Methods B and C)—The system shall allow for measurement of the applied head loss, thus hydraulic gradient, to within $\pm 5\%$. In addition, the ratio of initial head loss divided by final head loss over an interval of time shall be measured such that this computed ratio is accurate to within $\pm 5\%$. The head loss shall be measured with a pressure gage, electronic pressure transducer, engineer's scale, graduated pipette, or any other device of suitable accuracy. Falling head tests may be performed with either a falling headwater and constant tailwater elevation (Method B) or a falling headwater and rising tailwater elevation (Method C).

5.2.3 Constant Rate of Flow (Method D)—The system must be capable of maintaining a constant rate of flow through the specimen to within $\pm 5\%$. Flow measurement shall be by calibrated syringe, graduated pipette, or other device of suitable accuracy. The head loss across the specimen shall be measured to an accuracy of 5% or better using an electronic pressure transducer or other device of suitable accuracy. More information on testing with a constant rate of flow is given in the literature.⁴

5.2.4 System De-Airing—The hydraulic system shall be designed to facilitate rapid and complete removal of free air bubbles from flow lines.

5.2.5 Back Pressure System—The hydraulic system shall have the capability to apply back pressure to the specimen to facilitate saturation. The system shall be capable of maintaining the applied back pressure throughout the duration of hydraulic conductivity measurements. The back pressure system shall be capable of applying, controlling, and measuring the back pressure to 5% or better of the applied pressure. The back pressure may be provided by a compressed gas supply (see **Note 1**), a dead weight acting on a piston, or any other method capable of applying and controlling the back pressure to the tolerance prescribed in this paragraph.

NOTE 1—Application of gas pressure directly to a fluid will dissolve gas in the fluid. Any suitable technique, including separation of gas and liquid phases with a bladder, may be used to minimize dissolution of gas in the back pressure fluid.

5.3 Flow Measurement System—Both inflow and outflow volumes shall be measured unless the lack of leakage, continuity of flow, and cessation of consolidation or swelling can be verified by other means. Flow volumes shall be measured by a graduated accumulator, graduated pipette, vertical standpipe in conjunction with an electronic pressure transducer, or other volume-measuring device of suitable accuracy.

5.3.1 Flow Accuracy—Required accuracy for the quantity of flow measured over an interval of time is $\pm 5\%$.

5.3.2 De-Airing and Compliance of the System—The flow measurement system shall contain a minimum of dead space and be capable of complete and rapid de-airing. Compliance of the system in response to changes in pressure shall be minimized by using a stiff flow measurement system. Rigid tubing, such as metallic or rigid thermoplastic tubing, shall be used.

5.3.3 Head Losses—Head losses in the tubes, valves, porous end pieces, and filter paper may lead to error. To guard against such errors, the permeameter shall be assembled with no specimen inside and then the hydraulic system filled. If a constant or falling head test is to be used, the hydraulic pressures or heads that will be used in testing a specimen shall be applied, and the rate of flow measured with an accuracy of 5% or better. This rate of flow shall be at least ten times greater than the rate of flow that is measured when a GCL specimen is placed inside the permeameter and the same hydraulic pressures or heads are applied. If a constant rate of flow test is to be used, the rate of flow to be used in testing a specimen shall be supplied to the permeameter and the head loss measured. The head loss without a specimen shall be less than 0.1 times the head loss when a GCL specimen is present.

5.4 Permeant Interface Device (Bladder Accumulator)—A permeant interface device shall be used when a hazardous/corrosive or volatile test liquid, or both, is to be used as the permeant. The permeant interface device shall contain the test liquid in a closed chamber and allow neither possible contamination of flow measurement and pressure systems nor potential release of chemicals present in the test liquid to the breathing air, while maintaining the desired test pressures. A schematic diagram of a typical permeant interface device is shown in **Fig. 1**. The device consists of mainly a water chamber and a test liquid chamber, which are separated with a flexible bladder membrane. The device should be checked for leaks at the desired test pressures prior to the testing.

NOTE 2—The suppliers of the apparatus materials in contact with the test liquid (for example, permeant interface device, flexible membrane, and porous end pieces) may be consulted regarding chemical compatibility with the test liquid prior to testing.

5.5 Permeameter Cell Pressure System—The system for pressurizing the permeameter cell shall be capable of applying and controlling the cell pressure to within $\pm 5\%$ of the applied pressure. However, the effective stress on the test specimen (which is the difference between the cell pressure and the pore water pressure) shall be maintained to the desired value with an accuracy of $\pm 5\%$ or better. The device for pressurizing the cell may consist of a reservoir connected to the permeameter cell and partially filled with de-aired water, with the upper part of the reservoir connected to a compressed gas supply or other source of pressure (see **Note 3**). The gas pressure shall be controlled by a pressure regulator and measured by a pressure gage, electronic pressure transducer, or any other device capable of measuring to the prescribed tolerance. A hydraulic system pressurized by dead weight acting on a piston or any other pressure device capable of applying and controlling the permeameter cell pressure to the tolerance prescribed in this paragraph may be used.

⁴ Olson, H. W., Morin, R. H., and Nichols, R. W., "Flow Pump Applications in Triaxial Testing," *Symposium on Advanced Triaxial Testing of Soil and Rock*, ASTM STP 977, ASTM International, 1988, pp. 68–81.

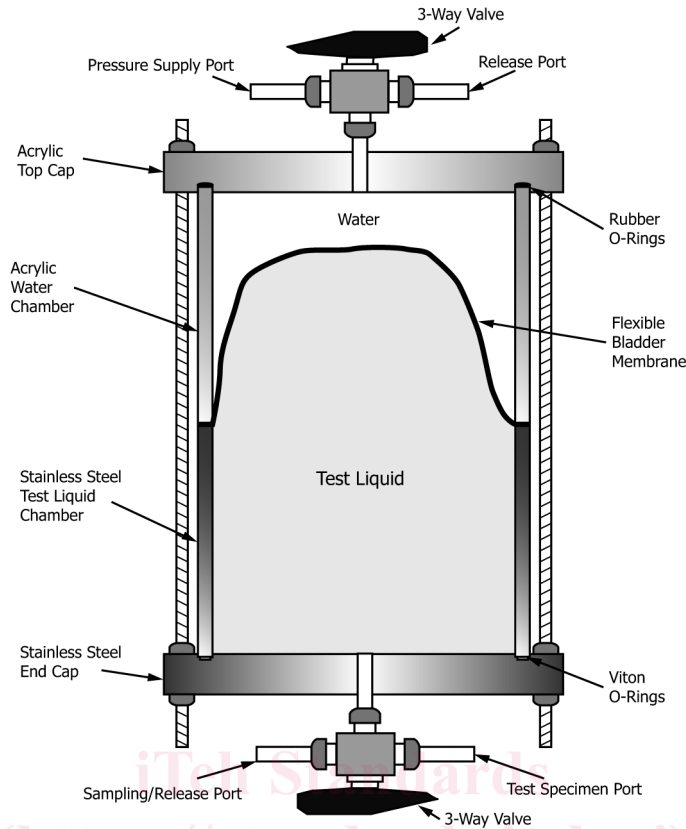

FIG. 1 Schematic Diagram of Permeant Interface Device

NOTE 3—De-aired water is commonly used for the cell fluid to minimize potential for diffusion of air through the membrane into the specimen. Other fluids, such as oils, which have low gas solubility are also acceptable, provided they do not react with components of the permeameter. Also, use of a long (approximately 5 to 7 m) tube connecting the pressurized cell liquid to the permeameter cell helps to delay the appearance of air in the cell fluid and to reduce the flux of dissolved air into the cell.

5.6 *Permeameter Cell*—An apparatus shall be provided in which the GCL specimen and porous end pieces, enclosed by a membrane sealed to the cap and base, are subjected to controlled fluid pressures. A schematic diagram of a typical cell is shown in Fig. 2.

5.6.1 The permeability cell may allow for observation of changes in height of the GCL specimen, either by observation through the cell wall using a cathetometer or other instrument, or by monitoring of either a loading piston or an extensometer extending through the top plate of the cell bearing on the top cap and attached to a dial indicator or other measuring device. The piston or extensometer should pass through a bushing and seal incorporated into the top plate and shall be loaded with sufficient force to compensate for the cell pressure acting over the cross-sectional area of the piston where it passes through the seal. If deformations are measured, the deformation indicator shall be a dial indicator or cathetometer graduated to 0.3 mm (0.01 in.) or better and having an adequate travel range. Any other measuring device meeting these requirements is acceptable.

5.6.2 In order to facilitate gas removal, and thus saturation of the hydraulic system, four drainage lines leading to the specimen, two each to the base and top cap, are recommended. The drainage lines shall be controlled by no-volume-change valves, such as ball valves, and shall be designed to minimize dead space in the lines.

5.7 *Top Cap and Base*—An impermeable, rigid top cap and base shall be used to support the specimen and provide for transmission of permeant liquid to and from the specimen. The diameter or width of the top cap and base shall be equal to the diameter or width of the specimen $\pm 5\%$. The base shall prevent leakage, lateral motion, or tilting, and the top cap shall be designed to receive the piston or extensometer, if used, such that the piston-to-top cap contact area is concentric with the cap. The surface of the base and top cap that contacts the membrane to form a seal shall be smooth and free of scratches.

5.8 *Flexible Membranes*—The flexible membrane used to encase the specimen shall provide reliable protection against leakage. The membrane shall be carefully inspected prior to use and if any flaws or pinholes are evident, the membrane shall be discarded (see Note 4). To minimize restraint of the specimen, the diameter or width of the unstretched membrane shall be between 90 and 95 % of that of the specimen. The membrane shall be sealed to the specimen base and cap with rubber O-rings for which the unstressed inside diameter or width is less than 90 % of the diameter of width of the base and cap, or by any other method that will produce an adequate seal.

NOTE 4—Membranes may be tested for flaws by placing them around a form sealed at both ends with rubber O-rings, subjecting them to a small air

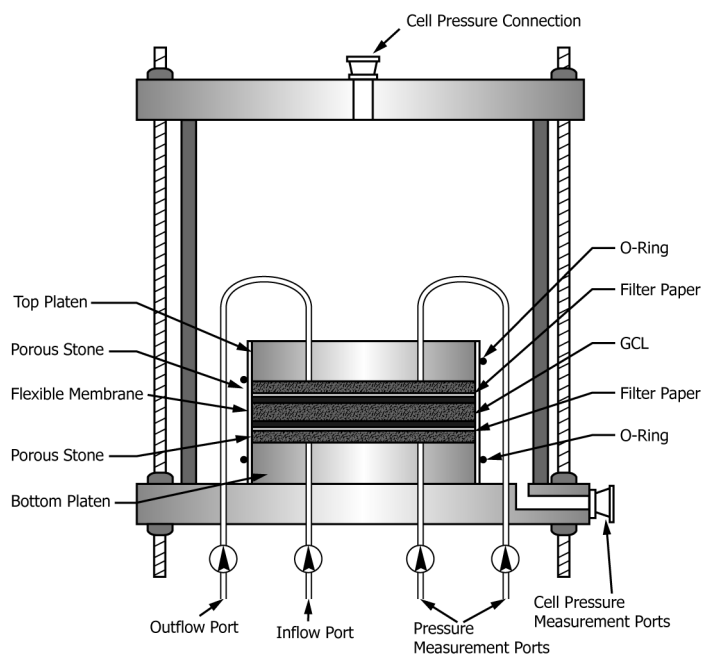

FIG. 2 Schematic Diagram of Permeameter Cell

pressure on the inside, and then dipping them into water. If air bubbles come up from any point on the membrane, or if any visible flaws are observed, the membrane shall be discarded. In some cases, when there are no compatible membranes available, the specimen may be wrapped by a very thin and flexible sheet/film/tape of chemically resistive and compatible material such as TFE-fluorocarbon prior to placement of the flexible membrane.

5.9 *Porous End Pieces*—The porous end pieces shall be of silicon carbide, aluminum oxide, or other material that is not attacked by the specimen or permeant liquid. The end pieces shall have plane and smooth surfaces and be free of cracks, chips, and nonuniformities. They shall be checked regularly to ensure that they are not clogged.

5.9.1 The porous end pieces shall be the same diameter or width ($\pm 5\%$) as the specimen, and the thickness shall be sufficient to prevent breaking.

5.9.2 The hydraulic conductivity of the porous end pieces shall be significantly greater than that of the specimen to be tested. The requirements outlined in 5.3.3 ensure this.

5.10 *Filter Paper*—To prevent intrusion of material into the pores of the porous end pieces, one or more sheets of filter paper shall be placed between the top and bottom porous end pieces and the specimen (see Note 5). The filter paper shall have a negligibly small hydraulic impedance. The requirements outlined in 5.3.3 ensure that the impedance is small.

NOTE 5—The type of filter paper recommended is Whatman No. 1 (or equivalent), that has a particle retention capability greater than 11 μm .

NOTE 6—For solutions with high suspended solids levels, clogging can be an important consideration. In these cases, nonwoven geotextiles can be used on both sides of the GCL specimen, in lieu of porous stones and filter paper that can be more susceptible to particulate clogging. Some laboratories first pass high suspended solids solutions through a 100-mesh stainless steel screen to filter out solids.

5.11 *Trimming Equipment*—Specific equipment for trimming the specimen to the desired diameter will vary depending on quality and characteristics of the sample and the procedure used to prepare the specimen. The following items, however, are commonly used: razor knife, cutting dyes, carpet knife, and scissors.

5.12 *Devices for Measuring the Dimensions of the Specimen*—Devices used to measure the dimensions of the specimen shall be capable of measuring to the nearest 0.3 mm (0.01 in.) or better and shall be constructed such that their use will not disturb the specimen.

5.13 *Balance*—The balance shall be suitable for determining the mass of the specimen and shall be selected as discussed in Guide D4753. The mass of specimens less than 100 g shall be determined to the nearest 0.01 g. The mass of specimens 100 g or larger shall be determined to the nearest 0.1 g. The mass of specimens larger than 1000 g shall be determined to the nearest 1.0 g.

5.14 *Equipment for Mounting the Specimen*—Equipment for mounting the specimen in the permeameter cell shall include a membrane expander or cylinder, and rings for expanding and placing O-rings on the base and top cap to seal the membrane.

5.15 *Vacuum Pump*—To assist with de-airing of water or, if applicable, the test liquid.

5.16 *Temperature Maintaining Device*—The temperature of the permeameter, test specimen, and reservoir(s) of test liquid shall not vary more than $\pm 3\text{ }^\circ\text{C}$ ($\pm 5.7\text{ }^\circ\text{F}$). Normally, this is accomplished by performing the test in a room with a temperature of $22 \pm 3\text{ }^\circ\text{C}$. If such a room is not available, the apparatus shall be placed in a water bath, insulated chamber, or other device that maintains a temperature within the specified tolerance. The temperature shall be periodically measured and recorded.

5.17 *Water Content Containers*—The containers shall be in accordance with Test Methods **D2216**.

5.18 *Drying Oven*—The oven shall be in accordance with Specification **E145**.

6. Reagents

6.1 *Deionized Water:*

6.1.1 *De-Aired Water*—To aid in saturating the test specimen as much as possible, de-aired water should be used when appropriate. Water can be de-aired by boiling, by spraying a fine mist of water into an evacuated vessel attached to a vacuum source, or by forceful agitation of water in a container attached to a vacuum source. If boiling is used, care shall be taken not to evaporate an excessive amount of liquid which can lead to a larger mineral concentration in the water than desired. To prevent dissolution of air back into the water, de-aired water shall not be exposed to air for prolonged periods.

6.2 *Test Liquids:*

6.2.1 The test liquid is the liquid used for permeation of the test specimen and it may be used in hydrating/saturating the specimen.

6.2.2 The test liquids should be specified and, if available, supplied along with chemical composition by the requester for both Test Scenarios 1 and 2.

6.2.3 Test liquids which may contain volatile chemicals or may cause any potential hazards during the de-airing process should not be de-aired, even when the test liquid is used to hydrate/saturate the specimen.

NOTE 7—Samples containing separate phase liquids should be left in a quiescent state for 24 h, to allow the non-aqueous phases to separate from the aqueous phase. The aqueous phase can then be decanted and used as the permeant liquid.

7. Test Specimen Preparation

7.1 Inspect the bulk GCL sample to be tested and record any disturbance, irregularity, or damages. Choose a representative section of the GCL sample to obtain the specimen for testing.

7.2 Place a template with known area (for example, 30.5 by 30.5 cm (12 by 12 in.)) on the selected section.

7.3 Utilizing a sharp utility knife or other suitable instruments, cut the bulk GCL sample to the exact size of the template. Carefully remove, with little or no loss of bentonite, and weigh the cut GCL sample (see **Note 8**).

NOTE 8—The weight of the GCL sample and the area of the template could be used to provide an estimate of the mass per unit area of the GCL sample.

7.4 Utilizing a squirt bottle with long nozzle and filled with test liquid, deionized water, wet the edges of the GCL sample to prevent bentonite loss during further handling and specimen preparation.

7.5 Carefully place the GCL sample on a flat, smooth surface.

7.6 Place a 100 ± 1 -mm (4 ± 0.04 -in.) diameter disc at the center of the GCL sample. With a thin marker, trace around the disc directly on the GCL backing.

7.7 Remove the disc. Using a sharp utility knife or other suitable instruments (see **Note 9**), cut through the traced line and into the upper GCL backing.

NOTE 9—Depending upon the type of geosynthetic backing, heated fine-point soldering irons or carpet knives have been successfully used for this purpose.

7.8 Utilizing a squirt bottle with long nozzle, apply test liquid, deionized water on the cut line. Allow the bentonite to hydrate for 2 to 5 min.

7.9 Using a sharp pair of scissors or other suitable instruments, cut through the bentonite and the lower geosynthetic backing on the cut line. Add test liquid to the exposed bentonite, if required, to prevent any loss of bentonite.

7.10 Examine the exposed edge of the specimen to verify that geotextile fibers from the upper and lower geosynthetic backings are not interconnected. To ensure that fibers from the upper and lower geosynthetic backings are not connected, the edge of the geosynthetic backings may be slightly trimmed using a pair of sharp scissors.

NOTE 10—Once trimmed, a bentonite paste can be applied to the edges of the GCL to limit side wall leakage. Bentonite used to seal around the specimen edges should be taken from the GCL. Bentonite paste should be made using deionized distilled water. The bentonite paste should only be applied with minimal pressure along the outside perimeter, not on the top surface of the specimen. The bentonite paste should not be used to restore bentonite lost from the specimen edges due to poor handling.

7.11 The diameter of the specimen shall not be less than the diameter of the disc and no greater than 102 mm (4.0 in.).

7.12 The initial height and diameter of the specimen (clay portion) shall be measured to the tolerances specified in **5.12**.

7.13 Total mass of the specimen shall be measured to the tolerances specified in **5.13**. The total mass of the clay portion of the specimen shall be calculated by subtracting the weight of the geosynthetic backings using actual values or values supplied by manufacturer.

7.14 Initial water content of the GCL specimen (clay portion) shall be determined in accordance with Test Methods **D2216** by using the remaining material of the template size sample at a distance from the wetted areas.

8. Procedure

8.1 Specimen and Test Setup:

8.1.1 Schematic diagrams of the specimen and test setup are presented in Figs. 2 and 3.

8.1.2 Cut two filter paper sheets 100 ± 2 mm (4 ± 0.08 in.) in diameter. Soak the two porous end pieces and filter paper sheets in a container of the hydration liquid that will initially come in contact with the GCL.

8.1.3 Place the membrane on the membrane expander. Apply a thin coat of silicon high-vacuum grease to the sides of the end caps. Place one porous end piece on the base and place one filter paper sheet on the porous end piece, followed by the test specimen. Place the second filter paper sheet on top of the specimen followed by the second porous end piece and the top cap. Place the membrane around the specimen, and using the membrane expander or other suitable O-ring expander, place one or more O-rings to seal the membrane to the base and one or more additional O-rings to seal the membrane to the top cap. Additional membranes may be used, if desired, to encapsulate the test specimen and prevent leakage from the cell water to the specimen.

8.1.4 Attach flow tubing to the top cap, if not already attached, assemble the permeameter cell, and fill it with de-aired water or other cell fluid. Attach the cell pressure reservoir to the permeameter cell line. Fill the cell pressure reservoir with de-aired water, or other suitable liquid.

8.1.5 Scenario 1—Attach the hydraulic system to the influent and effluent lines.

8.1.6 Scenario 2—Attach the hydraulic system to the permeant interface device filled with the test liquid, and attach the permeant interface device to the influent and effluent lines.

8.2 Back Pressure Saturation/Hydration and Consolidation:

8.2.1 Scenario 1 (Phase 1)—Saturate/hydrate and consolidate the specimen with water as Test Liquid 1.

8.2.2 Scenario 2—Saturate/hydrate and consolidate the specimen with test liquid as Test Liquid 2.

8.2.3 If the test conditions are not specified otherwise by the requester, the following procedure should be followed.

8.2.4 Increase the cell pressure to 105 kPa (15 psi) and then back pressure to 70 kPa (10 psi) on both ends of the specimen. Carefully flush test liquid through the drainage lines until all visible air bubbles have been removed.

8.2.5 Increase the cell pressure and back pressure simultaneously in increments of 70 kPa (10 psi) in 1-min intervals until a final cell pressure of 550 kPa (80 psi) and a final back pressure of 515 kPa (75 psi) are obtained.

8.2.6 Maintain the cell pressure of 550 kPa (80 psi) and back pressure of 515 kPa (75 psi) for a period of 48 h to allow saturation, hydration, swell, and consolidation to occur.

NOTE 11—Test Method D5887/D5887M procedure uses a total cell pressure of 550 kPa (80 psi), a back pressure of 515 kPa (75 psi), and an influent pressure of 530 kPa (77 psi). This results in an average effective stress of 27.5 kPa (4 psi), which may not be representative of site conditions. If warranted by site conditions, the requester may specify different pressures in order to more closely mimic expected field conditions. Practically speaking, average

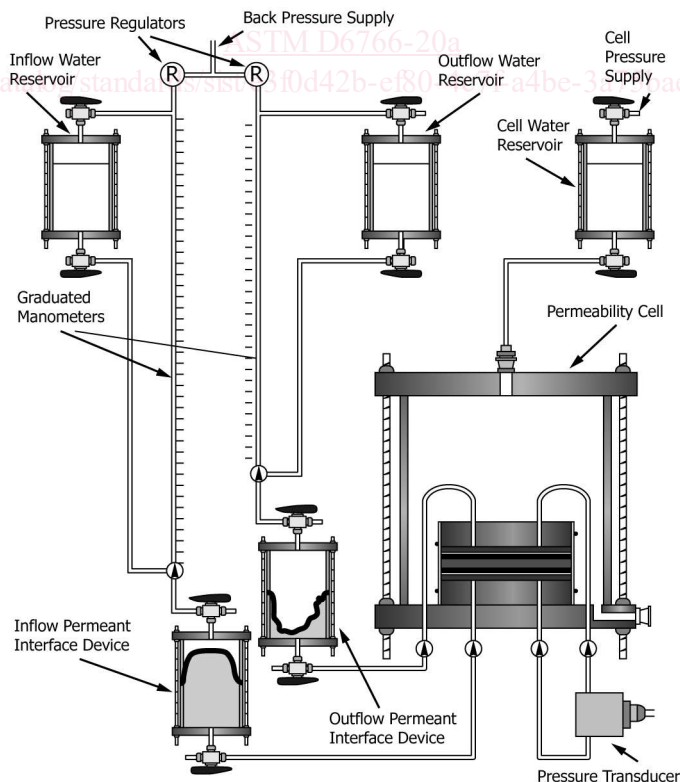

FIG. 3 Schematic Diagram of Test Setup