



Designation: A1056 – 20

Standard Specification for Cast Iron Couplings Used for Joining Hubless Cast Iron Soil Pipe and Fittings¹

This standard is issued under the fixed designation A1056; the number immediately following the designation indicates the year of original adoption or, in the case of revision, the year of last revision. A number in parentheses indicates the year of last reapproval. A superscript epsilon (ϵ) indicates an editorial change since the last revision or reapproval.

1. Scope

1.1 This specification covers the materials and testing of cast iron couplings for joining hubless cast iron soil pipe and fittings for sizes 1½ to 10 in.

1.2 It is the purpose of this specification to furnish information as to the characteristics of a particular sleeve type coupling when applied to cast iron soil pipe and fittings manufactured in accordance with Specification A888, latest revision, and CISPI Designation 301, latest revision.

1.3 The values stated in inch-pound units are to be regarded as standard. The values given in parentheses are mathematical conversions to SI units that are provided for information only and are not considered standard.

1.4 The following precautionary caveat pertains only to the test method portion, Section 8, of this specification. *This standard does not purport to address all of the safety concerns, if any, associated with its use. It is the responsibility of the user of this standard to establish appropriate safety, health, and environmental practices and determine the applicability of regulatory limitations prior to use.*

1.5 *This international standard was developed in accordance with internationally recognized principles on standardization established in the Decision on Principles for the Development of International Standards, Guides and Recommendations issued by the World Trade Organization Technical Barriers to Trade (TBT) Committee.*

2. Referenced Documents

2.1 ASTM Standards:²

A48/A48M Specification for Gray Iron Castings

A644 Terminology Relating to Iron Castings

¹ This specification is under the jurisdiction of ASTM Committee A04 on Iron Castings and is the direct responsibility of Subcommittee A04.75 on Gaskets and Coupling for Plumbing and Sewer Piping.

Current edition approved May 1, 2020. Published May 2020. Originally approved in 2008. Last previous edition approved in 2017 as A1056 – 12 (2017). DOI: 10.1520/A1056-20.

² For referenced ASTM standards, visit the ASTM website, www.astm.org, or contact ASTM Customer Service at service@astm.org. For *Annual Book of ASTM Standards* volume information, refer to the standard's Document Summary page on the ASTM website.

A888 Specification for Hubless Cast Iron Soil Pipe and Fittings for Sanitary and Storm Drain, Waste, and Vent Piping Applications

C564 Specification for Rubber Gaskets for Cast Iron Soil Pipe and Fittings

D2240 Test Method for Rubber Property—Durometer Hardness

E8/E8M Test Methods for Tension Testing of Metallic Materials

2.2 ASME Standards:³

ASME B18.2.1 Square and Hex Bolt and Screws Inch Series

ASME B18.1.2 Square and Hex Nuts (Inch Series)

2.3 CISPI Standard:⁴

CISPI 301 Specification for Hubless Cast Iron Soil Pipe and Fittings for Sanitary and Storm Drain, Waste and Vent Piping Applications

3. Terminology

3.1 Definitions:

3.1.1 Definitions of the following terms used in this specification are found in Terminology A644: elastomeric, durometer, and dynamic.

3.2 Definitions of Terms Specific to This Standard:

3.2.1 *center stop, n*—an integral part of the gasket centered on the axial length of the gasket intended to limit the insertion depth of the pipe and/or fitting to be coupled.

3.2.2 *clamp assembly, n*—that portion of the coupling excluding the gasket, nuts, and bolts.

3.2.3 *coupling, n*—the complete assembly.

3.2.4 *fitting, n*—parts of a pipeline other than straight pipes, valves, or couplings.

3.2.5 *gasket, n*—the elastomeric portion of the coupling.

3.2.6 *joint, n*—the point of assembly consisting of the coupling and the joined pipes or fittings, or both.

3.2.7 *manufacturer of the clamp assembly, n*—the entity that casts the clamp assembly.

³ Available from American Society of Mechanical Engineers (ASME), ASME International Headquarters, Three Park Ave., New York, NY 10016-5990, http://www.asme.org.

⁴ Available from Cast Iron Soil Pipe Institute (CISPI), 5959 Shallowford Rd., Suite 419, Chattanooga, TN 37421, http://www.cispi.org.

3.2.8 *manufacturer of the coupling, n*—the entity that assembles the components of the coupling such as the gasket and the clamp assembly.

3.2.9 *manufacturer of the gasket, n*—the entity that produces the elastomeric portion of the coupling.

4. Materials and Manufacture

4.1 Physical properties of gaskets shall comply with Specification C564 and the dimensions, material specifications, and physical and chemical properties as shown in Figs. 1 and 2 and Tables 1 and 2.

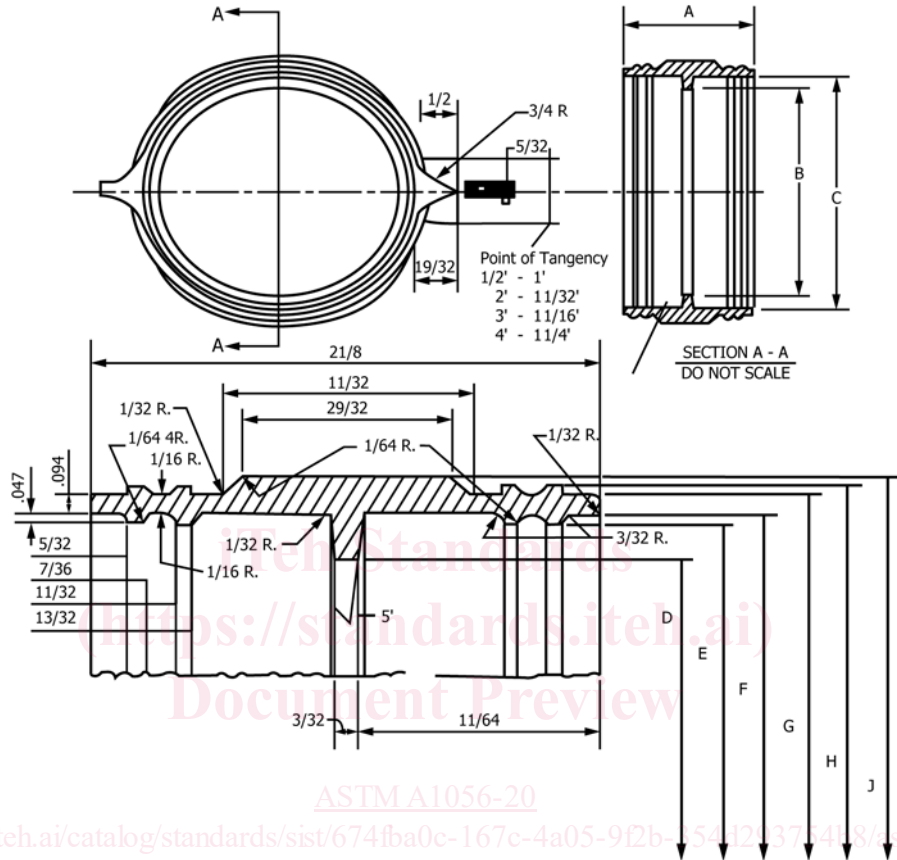

ASTM A1056-20

https://standards.iteh.ai/catalog/standards/sist/674fba0c-167c-4a05-9f2b-654129375418/astm-a1056-20

	Dimensions, in. (mm)							
	1 1/2 (38.100)	2 (50.800)	3 (76.200)	4 (101.600)	5 (127.000)	6 (152.400)	8 (203.200)	10 (254.000)
A	2.125 (53.975)	2.125 (53.975)	2.125 (53.975)	2.125 (53.975)	3.000 (76.200)	3.000 (76.200)	4.000 (101.600)	4.000 (101.600)
B	1.531 (38.887)	1.969 (50.013)	2.969 (75.413)	4.000 (101.600)	4.969 (126.213)	5.969 (151.613)	7.969 (202.413)	10.085 (256.159)
C	1.937 (49.200)	2.344 (59.538)	3.344 (84.938)	4.406 (111.912)	5.344 (135.737)	6.344 (161.138)	8.344 (211.938)	10.460 (265.684)
D	1.531 (38.887)	1.969 (50.013)	2.969 (75.413)	4.000 (101.600)	4.969 (126.213)	5.969 (151.613)	7.969 (202.413)	10.085 (256.159)
E	1.037 (26.340)	2.250 (57.150)	3.250 (82.550)	4.313 (109.550)	5.250 (133.350)	6.250 (158.750)	8.250 (209.550)	10.366 (263.296)
F	1.937 (49.200)	2.344 (59.538)	3.344 (84.938)	4.406 (111.912)	5.344 (135.737)	6.344 (161.138)	8.344 (211.938)	10.460 (265.684)
G	2.125 (53.975)	2.531 (64.287)	3.531 (89.687)	4.594 (116.688)	5.532 (140.513)	6.532 (165.913)	8.532 (216.713)	10.650 (270.510)
H	2.219 (56.363)	2.625 (66.675)	3.625 (92.075)	4.684 (118.974)	5.626 (142.900)	6.626 (168.300)	8.626 (219.100)	10.744 (272.898)
J	2.313 (58.750)	2.719 (69.063)	3.719 (94.463)	4.781 (121.437)	5.720 (145.288)	6.720 (170.688)	8.720 (221.488)	10.838 (275.285)

NOTE 1—Dimensional tolerances to be RMA Class 3 (see Table 1).

FIG. 1 Rubber Gasket

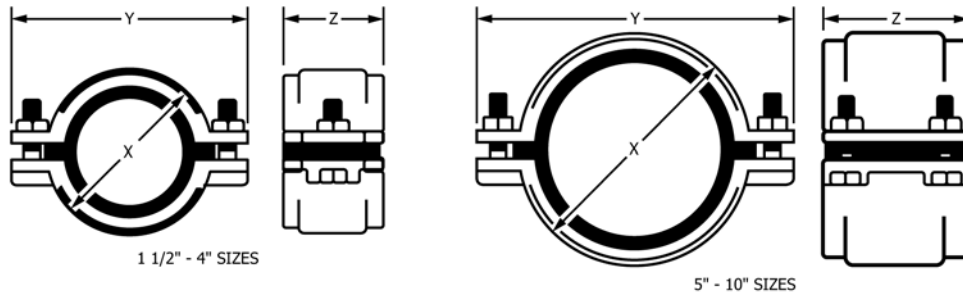

Nominal Size, in. (mm)		Coupling Size, in. (mm)			Bolt Size, in. (mm)	
Coupling Size	Pipe Diameter	Height X	Width Y	Depth Z	No.	Size × Length
1½ (38)	1.90 ± 0.06 (48.26 ± 1.52)	2.875 (73.025)	4.50 (114.300)	2.125 (53.975)	2	0.375 × 1.50
2 (50)	2.35 ± 0.09 (59.69 ± 2.29)	3.375 (85.725)	4.875 (123.825)	2.125 (53.975)	2	0.375 × 1.50
3 (76)	3.35 ± 0.09 (85.09 ± 2.229)	4.25 (107.950)	6 (152.400)	2.125 (53.975)	2	0.375 × 1.50
4 (101)	4.38 +0.09/-0.05 (111.252 + 2.286 - 1.270)	5.25 (133.350)	7 (177.800)	2.125 (53.975)	2	0.375 × 1.50
5 (127)	5.30 +0.09/-0.05 (111.25 + 2.229 - 1.27)	6.25 (158.750)	8.625 (219.075)	3.125 (79.375)	4	0.375 × 1.50
6 (152)	6.30 +0.09/-0.05 (160.02 + 2.229 - 1.270)	7.50 (190.500)	9.25 (234.950)	3.125 (79.375)	4	0.375 × 1.50
8 (203)	8.38 +0.09/-0.09 (212.85 + 3.3 - 2.29)	9.50 (241.300)	11.75 (298.450)	4 (101.600)	4	0.375 × 2
10 (254)	10.56 ± 0.09 (268.22 ± 2.29)	11.813 (300.203)	14.33 (364.058)	4 (101.600)	4	0.375 × 2.25

NOTE 1—Tolerance shall be ±0.125 in. (0.975) unless otherwise specified.

FIG. 2 Clamp Assembly Dimensions

TABLE 1 Dimensional Tolerances for Rubber Gaskets (Inches)

Coupling Size	Fixed, ±	Closure, ±
1½	0.020	0.050
2	0.020	0.050
3	0.020	0.050
4	0.020	0.050
5	0.025	0.055
6	0.025	0.055
8	0.030	0.063
10	0.030	0.063

5. Elastomeric Gasket Requirements

5.1 The elastomeric gasket shall consist of one piece conforming to the physical requirements of Specification C564 with hardness (nominal durometer ± 5) 70 as tested in accordance with Test Method D2240.

5.1.1 The elastomeric gasket shall have an inside center stop that does not create an enlargement chamber or recess with a ledge, shoulder, or reduction of pipe area or offer an obstruction to flow.

5.1.2 The elastomeric gasket shall be free of defects that affect the use and serviceability.

6. Clamp Assembly Requirements

6.1 The clamp assembly material shall be class 25 cast iron and comply with 4.2.2 of this specification.

6.1.1 The clamp assembly shall comply with dimension specifications, as are given in Figs. 2-4. The clamp assembly shall consist of two sections that interlock using a nut and bolt. The clamp assembly shall have the minimum wall thickness along the ring wall and the minimum wall thickness along the ear wall, with tapered ends as shown on Fig. 4.

6.1.2 Clamp assemblies shall be tested to withstand no less than 125 % of manufacturer of the coupling’s stated installation torque or a minimum of 175 lbf-in. (19.77 N·m) of applied torque, whichever is greater, without visible signs of failure. The clamp assembly shall be tested over a steel mandrel of the appropriate diameter and torqued as required.

6.1.3 The clamp assembly shall be designed to accommodate maximum and minimum ODs of pipe and fittings as shown in Table 3.

7. Sampling

7.1 The manufacturer of the coupling shall, upon receipt of a shipment of clamp assemblies from the manufacturer of the clamp assemblies, take a random sampling of couplings

4.2 All cast iron parts shall be made of a minimum class 25 cast iron and shall show compliance to this requirement using test methods contained in Specification A48/A48M.

4.2.1 The manufacturer of the clamp assembly shall perform tests to determine mechanical properties of the iron used in the manufacture of iron soil couplings. Tension test specimens shall be employed. The manufacturer of the clamp assembly shall maintain a record of mechanical tests for a minimum of seven years.

4.2.2 Tensile Strength Test—Test bars shall be cast in accordance with the requirements of Specification A48/A48M. The machined test bar dimensions and drawing and dimensions of as-cast test bars are found in Fig. 1 of Specification A888. The tensile strength shall be determined in accordance with Test Methods E8/E8M. The tensile strength shall be not less than 25 000 psi (145 MPa).

4.2.3 Tension test reports shall include breaking load of test bars, machined diameter of test bar, and calculated tensile strength.

4.2.4 Analysis of castings or test bars after the time of production shall not be used as evidence of compliance to this specification.

4.3 Nuts and bolts shall be stainless steel Grade 304, shall conform to the requirements of ASME Specification B18.2.1 and B18.2.2, and shall not have screwdriver slots.

TABLE 2 Rubber Gasket Physical Requirements

NOTE 1—Material: The sealing sleeve shall be made from an elastomeric compound that meets the requirements of Specification C564.

NOTE 2—Physical Tests: The test specimens shall be obtained from finished sleeves and tested pursuant to the methods described in the following table.

Test	Physical Tests, Min or Max Requirements	ASTM Method
Tensile Strength	1500 psi (105.49 kg/cm) min	D412
Elongation	250 min	D412
Durometer (Shore A)	70 ± 5 at 76 ± 5	D2240
Accelerated Aging	15 % max tensile and 20 % max elongation deterioration, 10 points max; increase in hardness, all determinations after oven aging for 96 h at 158 °F (70 °C)	D573
Compression Set	25 % max after 22 h at 158 °F (70 °C)	D395 Method B
Oil Immersion	80 % max volume change after immersion in ASTM oil no. IRM903 for 70 h at 212 °F (100 °C)	D471
Ozone Cracking	No visible cracking at 2 times magnification of the gasket after 100 h. Exposure in 1.5 ppm ozone concentration at 100 °F (37.778 °C). Testing and inspection to be on gasket which is loop mounted to give approximately 20 % elongation of outer surface	D1149
Tear Resistance	Die C; 150 lb (68.089 mm) min per in. (25.400 mm) of thickness	D624
Water Absorption	20 % max by weight after 7 days at 158 °F (70 °C)	D471

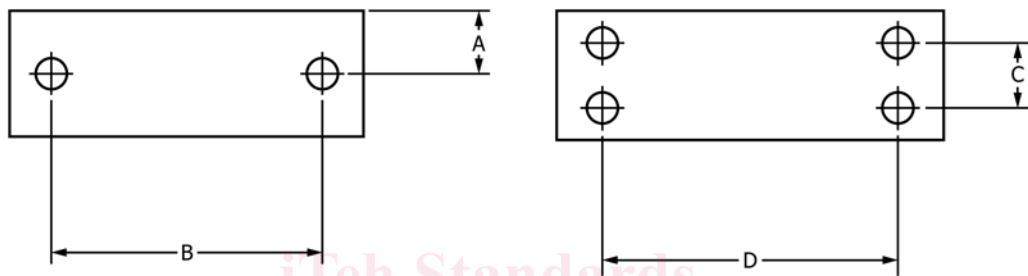

Style 1

Style 2

Nominal Pipe Size	Style 1		Style 2	
	A	B	C	D
1½	1.0625	3.7600	—	—
2	1.0625	4.1875	—	—
3	1.0625	5.1875	—	—
4	1.0625	6.3437	—	—
5	—	—	2.0625	7.5937
6	—	—	2.0625	8.6250
8	—	—	1.6562	10.875
10	—	—	1.6562	13.315

NOTE 1—Tolerance shall be ±0.125 in. (0.975) unless otherwise specified.

FIG. 3 Bolt Hole Layout Dimensions

manufactured therefrom and subject them to the tests specified in Section 8. If a coupling fails any of the tests, then the entire shipment of clamp assemblies of that size shall be rejected and returned to the manufacturer of the clamp assemblies. The manufacturer of the coupling shall retain the test results and related documentation for not less than seven years.

8. Coupling Requirements and Test Methods

8.1 Assemble each coupling tested according to the manufacturer of the coupling’s instructions between two sections of randomly selected hubless cast iron soil pipe meeting the requirements of CISPI 301 or Specification A888, or one section of randomly selected hubless cast iron soil pipe meeting the requirements of CISPI 301 or Specification A888 and a fitting and conduct the following tests: deflection and shear. In addition, an unrestrained hydrostatic test will be performed between two sections of machined steel pipe.

8.1.1 Deflection Test:

8.1.1.1 A test apparatus such as the one shown in Fig. 5 is suggested. Other testing apparatuses that provide restraint to the assembly shall also be permitted. Close the outboard ends of the pipe with test plugs.

8.1.1.2 Fill the assembly with water, expel all air, and hydrostatically pressurize to 4.3 psi (29.6 kPa) for the duration of the test. One pipe shall be rigidly supported and, while the assembly is under pressure, raise the opposite end of the other pipe ½ in. (12.7 mm) per lineal foot of pipe. Maintain the pressure for 5 min. Any leakage shall mean failure.

8.1.2 Shear Test:

8.1.2.1 Support two joined lengths of randomly selected hubless cast iron soil pipe on blocks, a minimum of 1½ in. (38.1 mm) high, at three locations. One length shall be a minimum of 24 in. (609.6 mm) in length, supported on blocks, one near the uncoupled end, and the other immediately

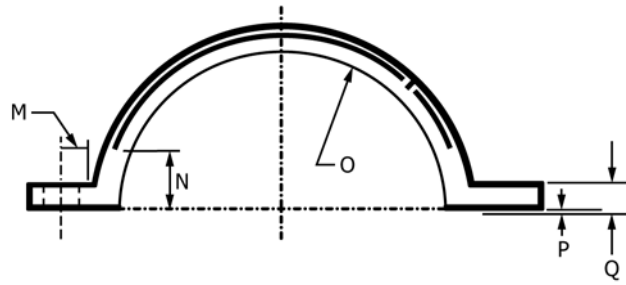

Pipe Size, in. (mm)	Dimensions, in. (mm)					
	Overall Tolerance	M	N	O (Dia)	P	Q
1½ (38.100)	±0.035 (0.889)	0.375 (9.525)	0.750 (19.050)	2.100 (53.340)	0.625 (15.875)	0.250 (6.350)
2 (50.800)	±0.035 (0.889)	0.375 (9.525)	0.875 (22.225)	2.560 (65.024)	0.625 (15.875)	0.281 (7.137)
3 (76.200)	±0.035 (0.889)	0.375 (9.525)	1.125 (28.575)	3.560 (90.424)	0.625 (15.875)	0.281 (7.137)
4 (101.600)	±0.035 (0.889)	0.375 (9.525)	1.250 (31.750)	4.590 (116.586)	0.625 (15.875)	0.281 (7.137)
5 (127.000)	±0.035 (0.889)	0.375 (9.525)	1.250 (31.750)	5.500 (139.700)	0.625 (15.875)	0.312 (7.925)
6 (152.400)	±0.035 (0.889)	0.375 (9.525)	1.250 (31.750)	6.530 (165.862)	0.625 (15.875)	0.312 (7.925)
8 (203.200)	±0.035 (0.889)	0.375 (9.525)	2.000 (50.800)	8.625 (219.075)	0.625 (15.875)	0.468 (11.887)
10 (254.000)	±0.035 (0.889)	0.187 (4.762)	2.250 (57.150)	10.875 (276.225)	0.625 (15.875)	0.468 (11.887)

NOTE 1—Tolerance shall be ±0.031 in. (0.08) unless otherwise specified.

FIG. 4 Flange Dimensions

TABLE 3 Dimensions and Tolerances for Hubless Pipe and Fittings

NOTE 1—Outside diameter of the barrel is permitted to have an out-of-round tolerance of plus or minus 0.04 in. for sizes 1½ through 5 in. and 0.07 in. for size 6 and larger.

Size, in. (mm)	Outside Diameter, in. (mm)
1½ (38)	1.90 ± 0.06 (48.26 ± 1.52)
2 (51)	2.35 ± 0.09 (59.69 ± 2.29)
3 (76.2)	3.35 ± 0.09 (85.09 ± 2.29)
4 (102)	4.38 ± 0.09/-0.05 (111.25 ± 2.29/-1.27)
5 (127)	5.30 ± 0.09/-0.05 (134.62 ± 2.29/-1.27)
6 (152)	6.30 ± 0.09/-0.05 (160.02 ± 2.29/-1.27)
8 (203)	8.38 ± -0.13/-0.09 (212.85 ± -2.29)
10 (254)	10.56 ± 0.09 (268.22 ± 2.29)

adjacent to the coupling. Firmly restrain this length in position as shown in Fig. 6. The other coupled length shall be a minimum of 5 ft (1.52 m) in length and supported by a single block 6 in. (152.4 mm) from the end of the pipe.

8.1.2.2 Fill the assembly with water and expel all air. Apply a load of 50 lb/in. of nominal diameter at a point 6 in. (152.4 mm) from the edge of the coupling upon a 12-in. (304.8-mm) length of (3 by 3) angle iron or load distribution pad located on the top of the pipe immediately adjacent to the coupling of the pipe having one support only. Under this loading there shall be no visible leakage or displacement of more than 3/8 in. (9.53 mm) from true alignment adjacent to the coupling, when an internal pressure equivalent to a 10-ft (3.05-m) head of water 4.3 psi (29.6 kPa) is applied. Maintain the load and internal pressure for 15 min.

8.1.3 Unrestrained Hydrostatic Test:

8.1.3.1 Assemble each coupling tested according to the manufacturer’s instruction between two sections of pipe and conduct the unrestrained hydrostatic test.

8.1.3.2 The assembly shall consist of a maximum outside diameter pipe connected to a minimum outside diameter pipe with diameters as referenced in Table 3 and lengths as shown in Fig. 7. Machine the plain ends of the pipe to be used for the unrestrained hydrostatic test to the correct diameters. Plain ends shall have 0.015-in. (0.38-mm) deep grooves machined circumferentially around them at 1/8-in. (3.18-mm) intervals down the pipe section for a distance equal to that covered by the elastomeric sleeve of the coupling being tested. The tool used to machine the grooves shall have a 60° included angle and cut into the pipe from a perpendicular position. The surface between the grooves shall be a lathe-turned surface of 125 RMS.

8.1.3.3 The plain ends of the pipe for the unrestrained hydrostatic test shall be uncoated and cleaned with acetone and thoroughly dried before each assembly.

8.1.3.4 Test Method:

(1) Support the pipe assemblies in a manner that does not restrain joint movement as shown in Fig. 7.

(2) Fill the pipe assembly (as required in 8.1.3) with water, expelling all air. Increase the hydrostatic pressure at a rate of 1 psi (6.9 kPa) every 30 s until the specified test pressure is reached. The specified test pressure shall be 20 psi (206.8 kPa) for 1½ in. (38.1 mm) through 5 in. (127 mm), 18 psi (186 kPa) for 6 in. (152.4 mm), 10 psi (103.4 kPa) for 8 in. (203.2 mm), and 9 psi (62 kPa) for 10 in. (254 mm) pipe. When the specified test pressure is reached, hold it for 10 min. Any leakage or axial joint movement of more than 0.150 in. (3.81 mm) shall mean failure.