



Designation: D5621 – 20

Standard Test Method for Sonic Shear Stability of Hydraulic Fluids¹

This standard is issued under the fixed designation D5621; the number immediately following the designation indicates the year of original adoption or, in the case of revision, the year of last revision. A number in parentheses indicates the year of last reapproval. A superscript epsilon (ϵ) indicates an editorial change since the last revision or reapproval.

1. Scope*

1.1 This test method covers the evaluation of the shear stability of hydraulic fluids in terms of the final viscosity that results from irradiating a sample of the hydraulic fluid in a sonic oscillator.

1.2 Evidence has been presented that a good correlation exists between the shear degradation that results from sonic oscillation and that obtained in a vane pump test procedure.²

1.3 This test method uses millimetres squared per second (mm^2/s), an SI unit, as the unit of viscosity. For information, the equivalent unit, cSt, is shown in parentheses.

1.4 *This standard does not purport to address all of the safety concerns, if any, associated with its use. It is the responsibility of the user of this standard to establish appropriate safety, health, and environmental practices and determine the applicability of regulatory limitations prior to use.*

1.5 *This international standard was developed in accordance with internationally recognized principles on standardization established in the Decision on Principles for the Development of International Standards, Guides and Recommendations issued by the World Trade Organization Technical Barriers to Trade (TBT) Committee.*

2. Referenced Documents

2.1 ASTM Standards:³

D445 Test Method for Kinematic Viscosity of Transparent and Opaque Liquids (and Calculation of Dynamic Viscosity)

D2603 Test Method for Sonic Shear Stability of Polymer-Containing Oils

D6022 Practice for Calculation of Permanent Shear Stability Index

D7042 Test Method for Dynamic Viscosity and Density of Liquids by Stabinger Viscometer (and the Calculation of Kinematic Viscosity)

3. Summary of Test Method

3.1 A convenient volume of hydraulic fluid is irradiated in a sonic oscillator for a period of time and the viscosities before and after irradiation are determined by Test Method **D445** and **D7042**. A standard reference fluid containing a readily sheared polymer is run frequently to ensure that the equipment imparts a controlled amount of sonic energy to the sample.

3.2 The conditions to obtain the data for the precision statement were: 30 mL sample, 12.5 min calibration, and 40 min sample irradiation at 0 °C jacket temperature.

4. Significance and Use

4.1 This test method was developed using Test Method **D2603**–91.

4.2 This test method permits the evaluation of shear stability with minimum interference from thermal and oxidative factors that may be present in some applications. It has been found applicable to fluids containing both readily sheared and shear-resistant polymers. Correlation with performance in the case of hydraulic applications has been established.

5. Apparatus

5.1 *Sonic Shear Unit*, fixed frequency oscillator and sonic horn.

5.2 *Auxiliary Equipment*—To facilitate uniform performance, the following auxiliary equipment is recommended:

5.2.1 *Cooling Bath or Ice Bath*, to maintain a jacket temperature of 0 °C.

5.2.2 *Griffin 50 mL Beaker*, borosilicate glass.

5.2.3 *Sonic-Insulated Box*, to enclose the sonic horn to reduce the ambient noise level produced by the sonic shear unit.

5.3 *Viscometer*—Any viscometer and bath meeting the requirements for determining kinematic viscosity: Test Method **D445** or **D7042**. Whichever method is chosen, that same

¹ This test method is under the jurisdiction of ASTM Committee **D02** on Petroleum Products, Liquid Fuels, and Lubricants and is the direct responsibility of Subcommittee **D02.07** on Flow Properties.

Current edition approved May 1, 2020. Published May 2020. Originally approved in 1994. Last previous edition approved in 2019 as D5621 – 19. DOI: 10.1520/D5621-20.

² Stambaugh, R. L., Kopko, R. J., and Roland, T. F., "Hydraulic Pump Performance—A Basis for Fluid Viscosity Classification," SAE Paper No. 901633. Available from Society of Automotive Engineers, 400 Commonwealth Dr., Warrendale, PA 15096.

³ For referenced ASTM standards, visit the ASTM website, www.astm.org, or contact ASTM Customer Service at service@astm.org. For *Annual Book of ASTM Standards* volume information, refer to the standard's Document Summary page on the ASTM website.

*A Summary of Changes section appears at the end of this standard

method must be used for the before and after samples as well as calibration samples.

6. Reference Fluids

6.1 The reference fluid is ASTM Reference Fluid B,⁴ a petroleum oil containing a polymer capable of being broken down by turbulence at high rates of shear. This oil has a viscosity of about 13.6 mm²/s (cSt) at 40 °C. The viscosity of a specific lot is supplied by the provider of that lot.

7. Calibration of Apparatus

7.1 The reference fluid provides a practical way to define the performance (severity level) of a sonic oscillator unit so that satisfactory comparison can be made between tests run on different days in the same unit and between tests run with different units.

7.2 The decrease in viscosity observed for a given hydraulic fluid on irradiation in an oscillator unit depends on a number of factors; these include sample volume, irradiation time, and oscillator power setting. Frequency of the generator is 23 kHz ± 2 kHz. Typical power settings are in the range of 50 W. Manual tuning of the oscillator-horn combination is also required in some instruments in order to ensure efficiency of energy coupling between the two units. The procedure described in 7.3 is recommended for establishing a reproducible performance level for a given unit.

7.3 Confirm and record the 40 °C viscosity of the reference fluid. Introduce 30 mL (room temperature) of the reference fluid into the 50 mL Griffin beaker. Immerse the beaker in ice water or a constant temperature bath at 0 °C until the sample fluid level is below the liquid level in the bath. The beaker should be maintained in a vertical position in the bath. Secure beaker in this position and condition the sample for 12.5 min before commencing irradiation. Immerse the sonic horn into the sample fluid until the tip is at least 10 mm below the surface of fluid (see Fig. 1) in order to ensure that the tip remains submerged during the test. Exercise care to avoid contact of the tip with the bottom of the beaker as this will shorten tip life. The horn should be placed in a vertical position in the fluid and centered in the beaker (a weighted ring stand may be used to support the horn in this position). True vertical positioning is not critical and is intended primarily to minimize liquid splashing during irradiation. Irradiate the fluid for 12.5 min at a preselected power setting. Determine the decrease in reference fluid viscosity measured at 40 °C. Repeat as necessary to determine the proper power setting to produce a viscosity change at 40 °C of 15.0 % (±1 %). Use this power setting for subsequent test runs. Daily recalibration of the apparatus is required because the power setting required to produce a stated viscosity loss will probably vary from day to day. Experience with a given apparatus set will determine

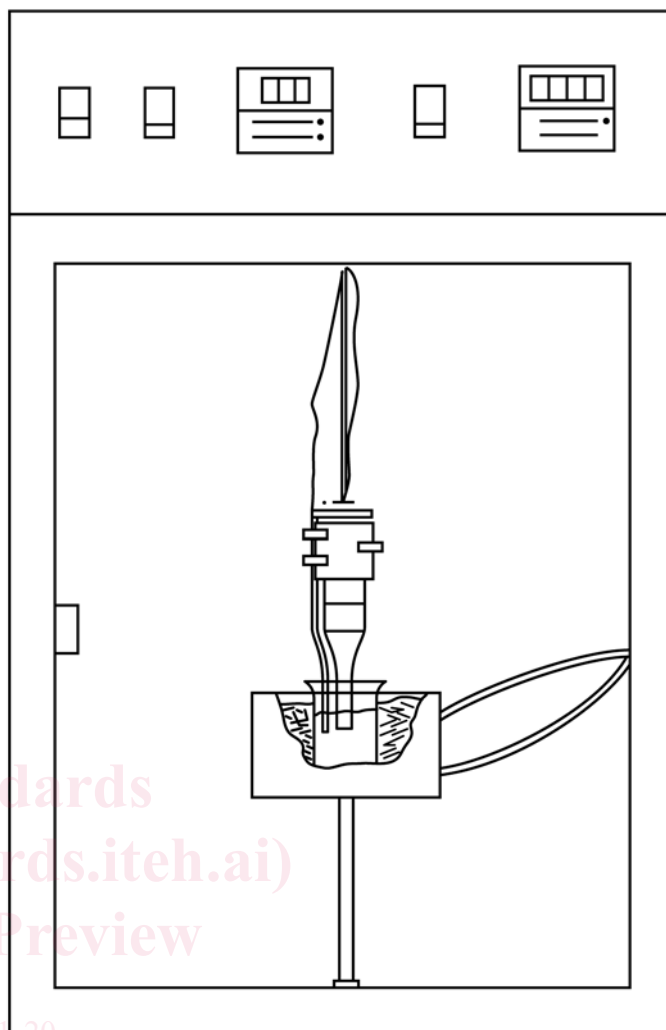

FIG. 1 Schematic of Sonic Probe Type Apparatus, Support Systems, Cabinet, and Power Supply

whether more frequent calibration is required. Calibration in this manner will ensure that repeatable severity levels are established.

8. Procedure

8.1 Clean the sonic horn using a lintless wiper and optional solvent and calibrate the apparatus as described in 7.3. Introduce 30 mL of the hydraulic fluid sample to be tested into a clean 50 mL Griffin beaker and immerse in the constant temperature bath at 0 °C. The beaker should be in a vertical position. Allow the sample to equilibrate for 12.5 min. Immerse the sonic horn in the fluid as described in 7.3. Irradiate the sample for 40 min at exactly the same power setting determined in 7.3. Upon completion of irradiation, remove the sample and clean the sonic horn in preparation for the next run.

8.2 Determine the viscosity of the sample by Test Method D445 or D7042 before and after irradiation.

8.2.1 If a method other than D445 is used to generate the kinematic viscosity data, apply appropriate relative-bias correction factors as found in the precision section of the method used before performing the calculations of this method.

⁴ The sole source of supply of the fluid known to the committee at this time is Evonik Oil Additives USA, 723 Electronic Drive, Horsham, PA 19044–2228. If you are aware of alternative suppliers, please provide this information to ASTM International Headquarters. Your comments will receive careful consideration at a meeting of the responsible technical committee,¹ which you may attend.