



Designation: **D5275—17** **D5275 – 20**

Standard Test Method for Fuel Injector Shear Stability Test (FISST) for Polymer Containing Fluids¹

This standard is issued under the fixed designation D5275; the number immediately following the designation indicates the year of original adoption or, in the case of revision, the year of last revision. A number in parentheses indicates the year of last reapproval. A superscript epsilon (ϵ) indicates an editorial change since the last revision or reapproval.

1. Scope*

1.1 This test method covers the measurement of the percent viscosity loss at 100 °C of polymer-containing fluids using fuel injector shear stability test (FISST) equipment. The viscosity loss reflects polymer degradation due to shear at the nozzle.

NOTE 1—Test Method **D2603** has been used for similar evaluation of this property. It has many of the same limitations as indicated in the significance statement. No detailed attempt has been undertaken to correlate the results by the sonic and the diesel injector methods.

NOTE 2—This test method was originally published as Procedure B of Test Methods **D3945**. The FISST method was made a separate test method after tests of a series of polymer-containing fluids showed that Procedures A and B of Test Methods **D3945** often give different results.

1.2 The values stated in SI units are to be regarded as standard. No other units of measurement are included in this standard.

1.2.1 *Exception*—PSI is mentioned in parentheses for instruments that have only PSI gauges. Horsepower, HP, is listed in parentheses since the motor labels display this value.

1.3 *This standard does not purport to address all of the safety concerns, if any, associated with its use. It is the responsibility of the user of this standard to establish appropriate safety, health, and environmental practices and determine the applicability of regulatory limitations prior to use.* Specific precautionary statements are given in Section 7.

1.4 *This international standard was developed in accordance with internationally recognized principles on standardization established in the Decision on Principles for the Development of International Standards, Guides and Recommendations issued by the World Trade Organization Technical Barriers to Trade (TBT) Committee.*

2. Referenced Documents

2.1 *ASTM Standards:*²

[D445 Test Method for Kinematic Viscosity of Transparent and Opaque Liquids \(and Calculation of Dynamic Viscosity\)](#)

[D2603 Test Method for Sonic Shear Stability of Polymer-Containing Oils](#)

[D3945 Test Method for Shear Shear Stability of Polymer-Containing Polymer-Containing Fluids Using a Diesel Injector Nozzle \(Withdrawn 1998\)](#)³

[D7042 Test Method for Dynamic Viscosity and Density of Liquids by Stabinger Viscometer \(and the Calculation of Kinematic Viscosity\)](#)

3. Summary of Test Method

3.1 The polymer-containing fluid is passed through a diesel injector nozzle at a shear rate that causes the less shear stable polymer molecules to degrade. The resultant degradation reduces the kinematic viscosity of the fluid under test. The reduction in kinematic viscosity, reported as percent loss of the initial kinematic viscosity, is a measure of the shear stability of the polymer-containing fluid.

4. Significance and Use

4.1 This test method evaluates the percent viscosity loss for polymer-containing fluids resulting from polymer degradation in the high shear nozzle device. Minimum interference from thermal or oxidative effects are anticipated.

¹ This test method is under the jurisdiction of ASTM Committee **D02** on Petroleum Products, Liquid Fuels, and Lubricants and is the direct responsibility of Subcommittee **D02.07** on Flow Properties.

Current edition approved May 1, 2017; May 1, 2020. Published May 2017; May 2020. Originally approved in 1992. Last previous edition approved in 2016 as **D5275—16**; **D5275 – 17**. DOI: [10.1520/D5275-17](https://doi.org/10.1520/D5275-17); [10.1520/D5275-20](https://doi.org/10.1520/D5275-20).

² For referenced ASTM standards, visit the ASTM website, www.astm.org, or contact ASTM Customer Service at service@astm.org. For *Annual Book of ASTM Standards* volume information, refer to the standard's Document Summary page on the ASTM website.

³ The last approved version of this historical standard is referenced on www.astm.org.

*A Summary of Changes section appears at the end of this standard

4.2 This test method is not intended to predict viscosity loss in field service for different polymer classes or for different field equipment. Some correlation for a specific polymer type in specific field equipment can be possible.

5. Apparatus

5.1 The apparatus consists of two fluid reservoirs, a single-plunger diesel fuel injection pump with an electric motor drive, a pintle-type fuel injection nozzle installed in a nozzle holder, and instrumentation for automatic operation. **Annex A1** contains a more complete description of the apparatus.^{4,5}

5.2 Viscometer—Any viscometer and bath meeting the requirements of Test Method **D445** or **D7042**. Whichever method is chosen, that same method must be used for the before and after samples as well as the calibration samples.

6. Reference Fluids

6.1 Diesel fuel is required for adjusting the nozzle valve assembly to the prescribed valve opening pressure.

6.2 Calibration fluid TL-11074^{6,5} is used to verify that the shearing severity of the apparatus is within the prescribed limits.

7. Precautions

7.1 During operation, the line between the pump and the nozzle holder is under high pressure. The safety shield should be in place when the apparatus is running. Stop the apparatus before tightening any fitting that is not properly sealed.

7.2 During operation and during the setting of the valve opening pressure, the fluid is discharged from the nozzle at high velocity and can inflict a serious wound if it strikes a part of the human body. Therefore, secure the nozzle assembly in position before the test apparatus is started. Similarly, take care to shield the operator from the nozzle discharge during the pressure-setting step.

8. Sampling

8.1 The test fluid shall be at room temperature, uniform in appearance and free of any visible insoluble material prior to placing in the test equipment.

8.2 After the test fluid has completed its twentieth cycle through the apparatus, drain it into a bottle for transfer to the kinematic viscosity measurement.

9. Calibration

9.1 Set the valve opening pressure of the diesel injector nozzle assembly to 20.7 MPa \pm 0.35 MPa (3000 psi \pm 50 psi) by means of a hand-actuated pump^{7,5} and diesel fuel.

9.2 Set the delivery rate of the pump to 534 cm³ \pm 12 cm³/min by the procedure described in **Annex A1**.

9.3 Verify the shearing severity of the apparatus by running the standard test procedure, described in **9.3.1**, with reference oil. Make this check every twentieth run when the apparatus is used frequently. Make this check before any other samples are tested if the apparatus has been idle for a week or more. The kinematic viscosity at 100 °C for the sheared reference oil is to be within the limits prescribed for the specific batch of the reference oil in use. Reference oil TL-11074^{6,5} shall have a total shear loss between 2.0 mm² and 2.2 mm²/s at 100 °C. This total shear loss is the difference between the reference oil kinematic viscosity at 100 °C before and after shear.

9.3.1 If the viscosity of the sheared oil does not fall within the above limits, make another shear test of the reference oil by the standard procedure. If the viscosity of the sheared oil still does not fall within the limits, take steps to correct the rating level of the test. Either mechanical difficulty or test technique is at fault.

10. Procedure

10.1 Shearing is accomplished by pumping the entire 100 cm³ test oil charge through the nozzle in successive passes or cycles. One cycle consists of pumping the oil from the lower reservoir (8) in **Fig. A1.1**, through the nozzle (5), and into the upper reservoir (6). At the end of each cycle, when the entire test oil charge has been collected in the upper reservoir (6), the pump (2) stops and the solenoid-operated drain valve (7) opens, draining the oil into the lower reservoir (8). The pump then restarts automatically for the next cycle. This process repeats for the number of cycles that have been set on the cycle counter. At the end of the last cycle, both solenoid-operated drain valves, (7) and (9) in **Fig. A1.1**, open and the test oil drains into the sample collection bottle (10).

⁴ The sole source of supply of the entire apparatus and spare parts (injectors) known to the committee at this time is Falex Corporation, 1020 Airpark Dr., Sugar Grove, IL 60554.

⁵ If you are aware of alternative suppliers, please provide this information to ASTM International Headquarters. Your comments will receive careful consideration at a meeting of the responsible technical committee,¹ which you may attend.

⁶ The sole source of supply of the apparatus known to the committee at this time is Tannas Co., 4800 James Savage Rd., Midland, MI 48642.

⁷ The sole source of supply of the apparatus known to the committee at this time is Waukesha Engine Div., 1000 W. St. Paul Ave., Waukesha, WI 53188. Part No. G-818-7.

10.2 Flush the apparatus with four separate 20 cm³ portions of the test oil as described in 10.2.1 and drain. Do not use solvent as part of the flush at any time because it could cause contamination.

10.2.1 Pour the first 20 cm³ charge of test oil into the lower reservoir, (8) in Fig. A1.1, through the funnel (14). Set the cycle counter for five cycles of the fluid through the nozzle, the pump timer for 15 s and the valve time for 20 s.

10.2.2 Repeat 10.2.1 three more times, draining and discarding each flush.

NOTE 3—These timer settings have been found satisfactory for all oils normally tested. The pump time should be sufficient for all oil to be pumped through the nozzle and into the upper reservoir, (6) in Fig. A1.1. The valve time should be sufficient for the oil to drain completely from the upper reservoir to the lower reservoir.

10.3 Pour 100 cm³ of the test oil into the lower reservoir through the funnel. Set the cycle counter for 20 cycles. Set a clean 120 cm³ bottle, (10) in Fig. A1.1, under the drain tube of the lower reservoir to receive the sheared sample. Start the pump and run until the 20 cycles have been completed. At the end of the twentieth cycle, both drain valves, (7) and (9) in Fig. A1.1, open automatically and the sample drains into the collection bottle, (10).

10.4 Measure the kinematic viscosity of the sheared oil and a sample of the unsheared oil at 100 °C by Test Method D445 or D7042.

10.4.1 If a method other than D445 is used to generate the kinematic viscosity data, apply appropriate relative-bias correction factors as found in the precision section of that method used before performing the calculations of this method.

11. Calculation

11.1 Calculate the percentage loss of viscosity of the sheared oil as follows:

$$VL = 100 \times (V_u - V_s) / V_u \quad (1)$$

where:

VL = viscosity loss, %,

V_u = kinematic viscosity of unsheared oil at 100 °C, mm²/s, and

V_s = kinematic viscosity of sheared oil at 100 °C, mm²/s.

12. Report

12.1 Report the following information:

12.1.1 Percentage viscosity loss as calculated in 11.1,

12.1.2 Kinematic viscosity of the unsheared oil at 100 °C,

12.1.3 Kinematic viscosity of the sheared oil at 100 °C,

12.1.4 Number of cycles,

12.1.5 For reference oil runs, the batch number of the reference oil, and

12.1.6 Specify this test method (ASTM D5275).

13. Precision and Bias⁸

13.1 The following criteria should be used for judging the acceptability of results:

13.1.1 *Repeatability*—The difference between successive test results, obtained by the same operator with the same apparatus under constant operating conditions on identical test material would, in the long run, and in the normal and correct operation of the test method, exceed the following value only in one case in twenty: 1.19 %.

13.1.2 *Reproducibility*—The difference between two single and independent results, obtained by different operators working in different laboratories on identical test material would, in the long run, and in the normal and correct operation of the test method, exceed the following value only in one case in twenty: 5.22 %.

NOTE 4—The indicated repeatability and reproducibility values represent the subtractive difference between the reported percentage viscosity loss values for the two determinations being compared.

13.1.3 *Bias*—All test results are relative to those of Calibration Fluid TL-11074.^{6,5} Therefore no estimate of bias can be justified.

14. Keywords

14.1 VII; fuel injector; polymer containing fluids; shear stability

⁸ Supporting data have been filed at ASTM International Headquarters and may be obtained by requesting Research Report RR:D02-1131. This test method was formerly Procedure B of Test Method D3945.

A1. DETAILS OF FUEL INJECTOR SHEAR STABILITY TEST (FISST)

A1.1 Apparatus:

A1.1.1 Fig. A1.1 shows the test schematically. A cycle counter, pump timer, valve timer, main power switch, and drain valve switch are mounted on an instrument panel not shown in Fig. A1.1.

A1.1.2 Specifications for the Fuel Injection Parts:

NOTE A1.1—The parts have not changed; only the parts supplier and part number have changed. Previous parts may be used until supply is exhausted.

A1.1.2.1 *Diesel Fuel Injection Pump* ((2) in Fig. A1.1), Waukesha pump 106712G that contains: Plunger and barrel assembly, 8.0 mm, PPK 1/2ZG ((17) in Fig. A1.2), camshaft, 6/1, PAC 26/1X ((34) in Fig. A1.2), delivery valve assembly, 6.0 mm cuffless, PVE 67/1Z ((16) in Fig. A1.2), plunger spring SP 769 CA ((31) in Fig. A1.1), and tappet assembly TP 7615-1A ((19) in Fig. A1.1).

A1.1.2.2 *Nozzle Holder*, ((4) in Fig. A1.1), Waukesha P/N 110743.

A1.1.2.3 *Nozzle Valve*, ((5) in Fig. A1.1), Waukesha P/N 110700.

NOTE A1.2—Take great care to avoid damage to the precision parts of the fuel injection equipment, namely the pump plunger and barrel ((17) in Fig. A1.2) and the nozzle valve assembly ((5) in Fig. A1.1). Service work on the injection equipment should be performed by a diesel fuel injection pump specialist or with reference to the manufacturer's service manual.

A1.1.2.4 *Nozzle Holder/Valve Assembly*, ((4 and 5) in Fig. A1.1), Waukesha P/N A75067E.

A1.1.3 *Motor*; 2.25 kW (3 hp), 1725 r/min, 230 V, 60 Hz, 182T frame ((1) in Fig. A1.1).

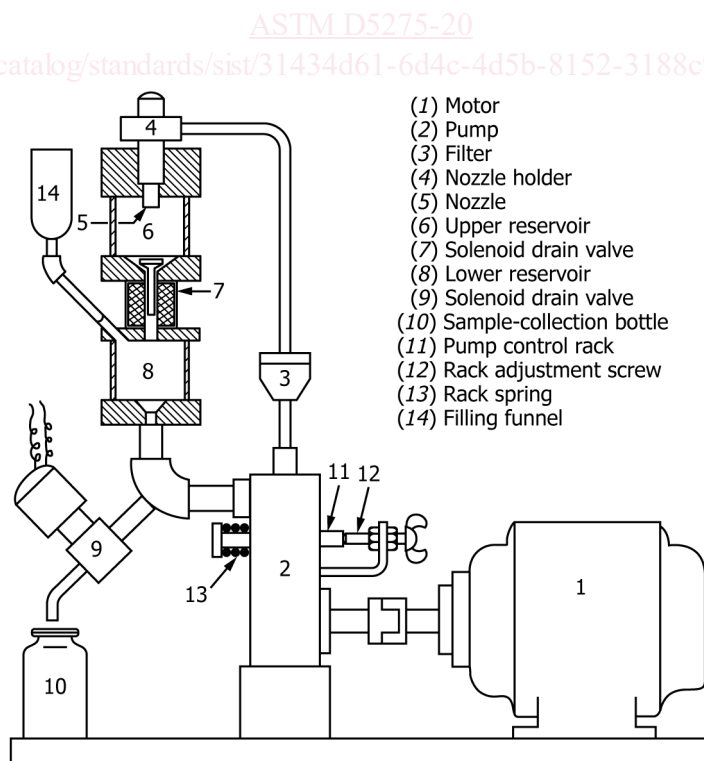

FIG. A1.1 Fuel Injector Shear Stability Test (FISST) (Schematic)

- (1) Housing
- (2) Petcock, bleeder
- (3) Screw, barrel locating
- (4) Plug, breather
- (5) Cover, inspection
- (6) Screw, fastening
- (7) Stud, fuel supply pump
- (8) Cover, pad-fuel supply pump
- (9) Plug, drain
- (10) Nut, delivery union
- (11) Washer
- (12) Holder, delivery valve
- (13) Spring, delivery valve
- (14) Plate, name
- (15) Gasket, delivery valve
- (16) Delivery valve assembly
- (17) Plunger and barrel assembly
- (18) Screw, control rack
- (19) Tappet assembly
- (20) Shell, tappet
- (21) Roller, tappet
- (22) Bushing
- (23) Pin
- (24) Petcock, overflow
- (25) Plug, closing
- (26) Plug, fuel inlet
- (27) Rack, control
- (28) Gear, segment
- (29) Sleeve, control
- (30) Seat, upper—plunger spring
- (31) Spring, plunger
- (32) Seat, lower—plunger spring
- (33) Cam
- (34) Camshaft
- (35) Seal, oil
- (36) Bearing, ball
- (37) Pad, felt
- (38) Plug
- (39) Screw, segment gear

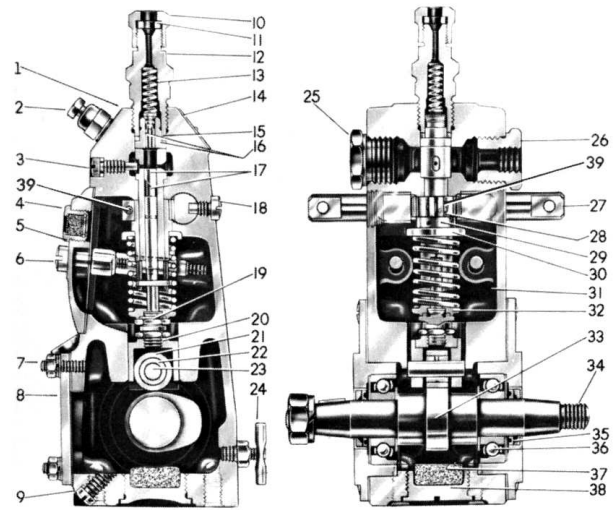

FIG. A1.2 Injection Pump of Fuel Injector Shear Stability Test (FISST)

iTech Standards
(<https://standards.itih.ai>)
Document Preview

A1.2 Method for Setting Injection Pump Rack:

[ASTM D5275-20](https://standards.itih.ai/catalog/standards/sist/31434d61-6d4c-4d5b-8152-3188c9e57e48/astm-d5275-20)

<https://standards.itih.ai/catalog/standards/sist/31434d61-6d4c-4d5b-8152-3188c9e57e48/astm-d5275-20>
A1.2.1 Preparation:

A1.2.1.1 Remove delivery valve holder (12) (numbers in parentheses refer to Fig. A1.2). Leave the body of the delivery valve (16) in place, but remove the internal check. Leave the delivery valve gasket (15) in place. The top of the pump plunger will be visible through the bore of the delivery valve body.

A1.2.1.2 Turn pump shaft (34), watching the top of the plunger (17) through the bore of the delivery valve body, until the plunger is at the bottom of its stroke.

A1.2.1.3 Insert a rod 4 mm in diameter by 40 mm or longer down through the open delivery valve body (16) and measure how high it stands above the top of the pump housing (1) to the nearest 0.50 mm.

A1.2.1.4 Rotate the pump shaft until the rod moves upward 5 mm. Mark the pump shaft or coupling so that it can be reset to this position again later.

A1.2.1.5 Taper one end of a length of stiff plastic translucent tubing (for example, 6.4 mm in diameter by 130 mm long nylon). Force the tapered end into the body of the delivery valve (16). Attach to it a 200 mm length of 8 mm diameter flexible tubing.

A1.2.1.6 Put sufficient light oil (such as a 4 mm² to 5 mm²/s at 100 °C neutral oil) in the reservoir to cover the inlet to the pump (26). Turn the pump shaft as necessary to let oil rise in the nylon tube at the delivery valve.

A1.2.1.7 Set the control rack (27) at about two-thirds full open position (rack moved away from coupling).

A1.2.1.8 Set pump shaft or coupling at the position established in A1.2.1.4.