

Foreword

ISO (the International Organization for Standardization) is a worldwide federation of national standards bodies (ISO member bodies). The work of preparing International Standards is normally carried out through ISO technical committees. Each member body interested in a subject for which a technical committee has been established has the right to be represented on that committee. International organizations, governmental and non-governmental, in liaison with ISO, also take part in the work.

Draft International Standards adopted by the technical committees are circulated to the member bodies for approval before their acceptance as International Standards by the ISO Council. They are approved in accordance with ISO procedures requiring at least 75 % approval by the member bodies voting.

International Standard ISO 4655 was prepared by Technical Committee ISO/TC 45, *Rubber and rubber products*.

ISO 4655 was first published in 1977. This second edition cancels and replaces the first edition, of which it constitutes a minor revision.

STANDARD PREVIEW
(standards.iteh.ai)

ISO 4655-1985
<https://standards.iteh.ai/catalog/standards/sist/48b93dae-dafa-4652-984e-4306f22bcc0e/iso-4655-1985>

Rubber — Reinforced styrene-butadiene latex — Determination of total bound styrene content

1 Scope and field of application

This International Standard specifies two methods for determining the total bound styrene content of styrene-butadiene rubber latices which are reinforced with polystyrene or a copolymer of butadiene and styrene.¹⁾

The two methods, the carbon/hydrogen method and the nitration method, give comparable results although they differ in principle. Either method may be used, according to preference.

NOTE — Any auxiliary materials present in the test sample may affect the accuracy of the determination.

2 References

ISO 123, *Rubber latex — Sampling*.

ISO 2453, *Styrene-butadiene copolymers — Determination of bound styrene content*.

3 Principles

In both methods, the latex is coagulated with 2-propanol and the coagulum is thoroughly washed, shredded and dried under vacuum.

In the carbon/hydrogen method, the dry polymer is subjected to controlled combustion and the carbon dioxide and water produced are quantitatively absorbed. The total bound styrene content is calculated from the masses of absorbed carbon dioxide and water. The method depends on the fact that the proportion of carbon in butadiene (88,82 %) differs from that in styrene (92,26 %).

In the nitration method, the dry polymer is nitrated and oxidized to convert its total bound styrene content to *p*-nitrobenzoic acid, which is separated by extraction and determined quantitatively by measuring its ultraviolet absorption at 265, 274 and 285 nm.

4 Carbon/hydrogen method

4.1 Reagents and materials

All recognized health and safety precautions shall be taken when carrying out the procedure specified in this International Standard.

During the analysis, unless otherwise stated, use only reagents of recognized analytical grade and only distilled water or water of equivalent purity.

4.1.1 Sulfuric acid, 96 % (*m/m*).

4.1.2 Soda asbestos granules, 710 to 1 000 μm , which change colour on absorption of carbon dioxide.

4.1.3 Magnesium perchlorate granules, 710 to 1 000 μm .

WARNING — This material is explosive. Handle in accordance with the manufacturer's instructions.

4.1.4 Copper(II) oxide, in wire form.

4.1.5 Copper(II) oxide/cobalt oxide (Co_3O_4) catalyst.

Ignite 98 g of copper(II) oxide at 700 ± 25 °C in a furnace for 1 h, cool, mix thoroughly with 8 g of cobalt(II) nitrate dissolved in the minimum quantity of water, heat at 120 °C with occasional stirring for 1 h, and ignite in a silica dish at 700 ± 25 °C in a furnace for 1 h.

4.1.6 Platinized asbestos, 5 % platinum content.

4.1.7 Silver wire cloth, having an average aperture width of 250 ± 15 μm , 70 mm square, rolled into a solid cylinder of 13 mm diameter.

The roll shall be degreased with ether, then immersed in nitric acid, $c(\text{HNO}_3) = 3$ mol/dm³ for a few seconds to remove any oxide or sulfide, washed copiously with water and dried for 1 h at 105 °C and 1 h at 700 ± 25 °C in a furnace.

4.1.8 Silver wire.

4.1.9 2-Propanol.

4.1.10 Benzoic acid.

4.1.11 Naphthalene.

4.1.12 Standard SBR, of accurately known bound styrene content (approximately 23,5 %), determined in accordance with ISO 2453.

4.2 Apparatus

Figure 1 shows the arrangement of a suitable combustion apparatus. Before being mixed, oxygen and air pass separately

1) Both methods are also suitable for the determination of the bound styrene content of non-reinforced styrene-butadiene rubber latices.

through a pressure-release vessel containing sulfuric acid (4.1.1), a guard tube (4.2.1) to remove carbon dioxide and moisture, a needle valve to control the rate of flow and a calibrated rotameter (4.2.2). The gas mixture flows through the purification tube (4.2.3) and another guard tube (4.2.1) into the combustion tube (4.2.4). The products of combustion pass into two absorption tubes (4.2.5), where the water and carbon dioxide are collected. Most of the purification tube and about half of the combustion tube are within the furnace (4.2.6).

All glass-to-glass joints shall be gas-tight and shall be either close-butted within heavy-walled silicone rubber tubing or of the cone and socket type. All joints between the purification tube and the absorption tubes shall remain gas-tight at 700 ± 25 °C.

4.2.1 Guard tubes, each of capacity approximately 35 cm^3 *, half-filled with the soda asbestos (4.1.2) at the gas entry end and half-filled with the magnesium perchlorate (4.1.3) at the gas exit end.

4.2.2 Rotameters, calibrated over the range 2 to $25 \text{ cm}^3/\text{min}$, one for oxygen and the other for air.

4.2.3 Purification tube, containing copper(II) oxide in wire form (4.1.4) and having the dimensions and contents specified in figure 2.

4.2.4 Combustion tube, of clear silica, having the dimensions, contents and fittings specified in figure 3.

The silver wire in the beak of the tube, in contact with the silver cloth (4.1.7), serves to prevent condensation of water. The copper(II) oxide/cobalt oxide catalyst (4.1.5) shall be packed into the tube carefully so that there is neither channelling nor restriction of gas flow.

The pyrolysis zone of the tube is encircled by 30 separate heaters, each with a power of approximately 50 W. Each heater consists of about 500 mm of nickel-chromium wire (diameter 0,5 mm) arranged in an open pattern, to ensure visibility into the tube, and occupying approximately 5 mm out of 8 mm of tube length. The whole of the pyrolysis zone of the tube is covered with a hinged, concentric stainless steel shield to conserve heat and protect from draughts.

The cone of the tube is closed by means of a 19/26 cap held in position by lugs and springs.

4.2.5 Absorption tubes of soda glass, of wall thickness 0,25 to 0,50 mm, having the dimensions and packing specified in figure 4.

The mass when empty of either tube a), for absorption of water, or tube b), for absorption of carbon dioxide, shall not exceed 7,5 g.

Each tube shall be carefully packed as rapidly as possible, to prevent ingress of moisture or carbon dioxide, avoiding tight packing or channelling, and both taps shall then be closed.

Tube a) shall be connected to the beak of the combustion tube, as shown in figure 1. The other end of the tube a) shall be connected to the end of tube b) which contains soda asbestos.

4.2.6 Furnace, as specified in figure 5.

The nickel-chromium wire wound around the smaller diameter silica tube develops a power of approximately 80 W. The wire wound around the larger diameter silica tube develops a power of approximately 135 W. Both tubes are individually maintained at 700 ± 25 °C, as indicated by the thermocouples, by means of variable transformers.

4.2.7 Platinum combustion boats, 16 mm × 5,5 mm, with platinum sheath.

4.2.8 Microbalance, accurate to 2 µg.

4.2.9 Timer, accurate to 1 s.

4.3 Sampling

Sampling shall be carried out in accordance with one of the methods specified in ISO 123.

4.4 Preparation of test sample

Dilute 5 g of latex with 2 to 3 cm^3 of water. Using a dropping tube, add the diluted latex to 100 cm^3 of the vigorously stirred 2-propanol (4.1.9) at approximately 23 °C, allow to settle and decant the supernatant liquid. Stir vigorously with water to wash the coagulum and drain thoroughly on a Büchner funnel. Wash copiously with water. Steep overnight in cold water, drain off the water, rinse well with 2-propanol, shred and then dry in an open dish under vacuum at approximately 50 °C to constant mass. All handling of the test sample shall be carried out in such a way as to avoid contamination.

If the test sample cannot be used immediately, store it under nitrogen in a cool, dark place.

4.5 Procedure

Insert the freshly packed purification tube (4.2.3) and combustion tube (4.2.4) into the furnace (4.2.6) and assemble the apparatus as indicated in figure 1. Pass oxygen and air, each at a rate of $20 \text{ cm}^3/\text{min}$, and raise the temperature of the furnace to 700 ± 25 °C.

Maintain the temperature of the furnace at 700 ± 25 °C for approximately 16 h to remove occluded water and traces of organic matter. Check the stability and performance of the combustion system by repeated assays of the benzoic acid (4.1.10) until replicates fall within $68,84 \pm 0,08$ % carbon and $4,95 \pm 0,03$ % hydrogen. Use 20 mg samples of the benzoic acid and the first heating schedule specified in the table.

Maintain the flow rates of oxygen and air at $20 \pm 1 \text{ cm}^3/\text{min}$ and the temperature of the furnace at 700 ± 25 °C, until replacement of the tube packings becomes necessary.

* Glassware with either cm^3 or ml marking is satisfactory for use with the procedure described in this International Standard.

Weigh approximately 15 mg of the naphthalene (4.1.11) into a platinum boat (4.2.7), which immediately previously had been boiled in hydrochloric acid, $c(\text{HCl}) \approx 5 \text{ mol/dm}^3$, ignited to red heat and cooled in a micro-desiccator. Insert the boat into a well-fitting platinum sheath and store in a desiccator.

Carry out the following operations a), b) and c) within 4 min :

a) Wearing chamois leather gloves, attach the approximately tared absorption tubes (4.2.5) to the combustion tube (4.2.4).

b) Remove the 19/26 cap from the combustion tube and insert the boat by means of a stainless steel rod (stored in a glass tube) until the lug of the boat just clears the 18th heater. Lightly replace the cap and allow 1 min for the gases to flush out the air, introduced with the boat, before clipping the cap firmly in place.

c) Open the four taps of the absorption tubes, starting with the tap nearest the furnace, and check that the gas flow is constant.

Switch on the heaters of the pyrolysis zone in accordance with the second heating schedule specified in the table. At the end of the combustion period (30 min), flush out the tubes for 20 min.

While the combustion is proceeding, cut the test sample finely, distribute 20 to 25 mg of it evenly along a platinum boat (4.2.7) prepared as above and transfer to a desiccator.

After 50 min, close the taps of the absorption tubes, in the reverse order to which they were opened, and start a stopwatch (to time subsequent weighing operations). Carefully detach the tubes and, wearing chamois leather gloves, gently wipe the side arms where they have been in contact with silicone rubber tubing. Convey the tubes, on a carrying rack, to the balance room.

Adjust the zero of the microbalance (4.2.8) and place the tube containing magnesium perchlorate [4.2.5 a)] on the supports of the left-hand pan and its tare flask, containing glass beads, on the right-hand pan. Add beads to the flask to obtain an approximate tare and finally counterbalance with the rider weights. Arrest the balance and allow the tube to equilibrate. When the stopwatch reads 5 min release the balance and 60 s later take the reading. Tare the other absorption tube [4.2.5 b)] in the same way, release the balance when the stopwatch reads 9 min, and 60 s later take the reading. Record the masses of the now conditioned absorption tubes for the sample determination.

Within a period of 4 min, re-attach the absorption tubes to the combustion tube and, using the platinum boat containing the test portion, repeat the above operations b) and c). In accordance with the third heating schedule specified in the table, switch on the heaters of the pyrolysis zone. At the end of the combustion period (30 min), flush out the tubes for 20 min and then repeat the procedure described in the immediately preceding two paragraphs (but omitting the addition of beads to the tare flasks).

Obtain, by difference, the masses of water and carbon dioxide produced by the test portion.

The apparatus may be used for the analysis of further test portions until the tube packings need to be replaced. To check the efficiency of the tube packings and the general performance of the apparatus, carry out daily an analysis of a sample of standard SBR (4.1.12). Replace the tube packings when the results of consecutive determinations of the carbon to hydrogen ratio of the standard SBR deviate more widely than 0,02.

4.6 Expression of results

Calculate the total bound styrene content S as a percentage by mass of the dry polymer content of the latex, from the equation

$$S = 29,083 \times \left[\frac{100 \times m_1}{(0,410\ 03 \times m_2) + m_1} \right] - 2\ 583,1$$

where

m_1 is the mass, in milligrams, of carbon dioxide produced by the test portion;

m_2 is the mass, in milligrams, of water produced by the test portion.

If the results of duplicate determinations do not agree within 0,5 unit, carry out two further determinations.

5 Nitration method

5.1 Reagents

All recognized health and safety precautions shall be taken when carrying out the procedure specified in this International Standard.

During the analysis, unless otherwise stated, use only reagents of recognized analytical grade and only distilled water or water of equivalent purity.

5.1.1 Nitric acid, 70 % (m/m).

5.1.2 Sodium hydroxide, solution, $c(\text{NaOH}) = 5 \text{ mol/dm}^3$.

5.1.3 Diethyl ether, free from peroxides.

5.1.4 Sodium chloride, saturated solution.

5.1.5 Sodium sulfate, anhydrous.

5.1.6 Sodium hydroxide, solution, $c(\text{NaOH}) = 0,1 \text{ mol/dm}^3$.

5.1.7 Standard SBR, of accurately known bound styrene content (approximately 23,5 %), determined in accordance with ISO 2453.

5.2 Apparatus

Ordinary laboratory apparatus, and

5.2.1 Boiling flask, 100 ml, with standard conical joint to fit the condenser (5.2.2).

5.2.2 Reflux condenser, water-cooled, of adequate length and configuration to prevent loss of nitric acid vapour, having standard conical joint to fit the flask (5.2.1).

5.2.3 Ultraviolet spectrometer, with 10 mm silica cells, capable of measuring absorbance (optical density) within the range 260 to 290 nm.

5.3 Sampling

Sampling shall be carried out in accordance with one of the methods specified in ISO 123.

5.4 Preparation of test sample

Prepare the test sample as specified in 4.4.

5.5 Procedure

Cut the test sample finely and weigh, to the nearest 0,1 mg, a portion having a mass in grams equal to 4,5 divided by the estimated percentage total bound styrene content. Place the test portion in the flask (5.2.1). Add 20 cm³ of nitric acid (5.1.1) and a few carborundum boiling chips to the flask. Place the flask on a cold hot-plate, heat and reflux vigorously for 16 to 18 h under the reflux condenser (5.2.2). Turn off the heat, pour 10 to 20 cm³ of water into the top of the condenser, and allow the water to be drawn into the flask as it cools.

NOTE — Carry out the following transfer operations and subsequent extractions carefully, since the skill with which they are performed determines the accuracy of the determination.

Transfer the reaction mixture to a 400 cm³ beaker, using water from a wash-bottle to rinse the flask and standard conical joint into the beaker. Cool the beaker to room temperature. Add 50 cm³ of the sodium hydroxide solution (5.1.2) to the flask and again rinse into the beaker with water. If the solution in the beaker is not strongly acid, as indicated by pH paper, add nitric acid to make it so. Cool to room temperature. Transfer the solution to a 500 cm³ separating funnel and rinse the beaker with water into the funnel.

Shake the solution in the separating funnel with 50 cm³ of the diethyl ether (5.1.3) and allow the layers to separate. Drain the lower aqueous layer into the beaker. Add 25 cm³ of the sodium chloride solution (5.1.4) to the ether layer. Drain a few cubic centimetres into the beaker to wash the stem of the separating funnel. Shake and allow layers to separate. Drain the aqueous layer into the beaker. Drain the ether layer into a 250 cm³ beaker containing 4 to 5 g of the sodium sulfate (5.1.5). Add a further 50 cm³ of ether to the separating funnel and drain a few cubic centimetres into the 250 cm³ beaker, to wash the stem of the funnel. Carefully swirl the 250 cm³ beaker and transfer the ether extract to a second separating funnel.

Extract the aqueous layer in the same manner twice more, drying each ether extract over the same sodium sulfate and collecting it in the second separating funnel.

Extract the combined ether extracts four times with 50 cm³ portions of the sodium hydroxide solution (5.1.6). Collect the

aqueous extracts in a 250 cm³ volumetric flask. After each extraction, drain a few cubic centimetres of the next portion of sodium hydroxide solution, before shaking, to rinse the stem of the separating funnel, adding the drainings to the volumetric flask. Dilute to the mark with the sodium hydroxide solution (5.1.6) and mix well. Pipette 25 cm³ into a second 250 cm³ volumetric flask, dilute to the mark with the sodium hydroxide solution (5.1.6) and mix well.

With the sodium hydroxide solution (5.1.6) in the reference cell of the ultraviolet spectrometer (5.2.3), measure the absorbance of the solution from the second volumetric flask at 265, 274 and 285 nm.

5.6 Determination of calibration constants (K_1 , K_2 and K_3)

Cut finely a sample of the standards SBR (5.1.7) and weigh, to the nearest 0,1 mg, at least three portions of approximately 190 mg. Carry out on each portion the nitration procedure specified in 5.5.

For each portion calculate the absorptivity (specific extinction coefficient) of nitrated styrene at each wavelength from the formula

$$A/C_0 = \frac{K'(1-X)}{X}$$

where

A is the absorbance of the solution;

C_0 is the concentration, in grams per cubic decimetre, of standard SBR in the solution;

K' is the absorptivity of nitrated butadiene = 0,373 at 265 nm, 0,310 at 274 nm and 0,265 at 285 nm;

X is the fraction of bound styrene in the standard SBR.

Calculate the average absorptivity K at each wavelength from the results on the three separate portions.

5.7 Expression of results

Calculate the total bound styrene S as a percentage by mass of the dry polymer content of the latex, from the equation

$$S = \frac{1}{3}(S_1 + S_2 + S_3)$$

where

$$S_1 = (100 A_1/C - 37,3)/(K_1 - 0,373)$$

$$S_2 = (100 A_2/C - 31,0)/(K_2 - 0,310)$$

$$S_3 = (100 A_3/C - 26,5)/(K_3 - 0,265)$$

where

A_1 , A_2 and A_3 are the absorbances of the solution at wavelengths of 265, 274 and 285 nm respectively;

C is the concentration of test portion calculated from

$$C = 0,4 m$$

m being the mass, in grams, of the original test portion, in 250 cm³;

K_1 , K_2 and K_3 are the absorptivities of nitrated styrene at wavelengths of 265, 274 and 285 nm respectively, determined as in 5.6.

If the results of duplicate determinations do not agree within 0,6 unit, carry out two further determinations.

6 Test report

The test report shall include the following particulars :

- the type and identification of the product tested;
- reference to this International Standard;
- the method used (carbon/hydrogen or nitration);
- the results and the method of expression used;
- any unusual features noted during the determination;
- any operation not included in this International Standard or in the International Standards to which reference is made, or regarded as optional.

Table — Heating schedules for carbon/hydrogen method

Time min	Heaters switched on		
	for benzoic acid	for naphthalene	for test portion
1	1 to 3	1 to 5	1 to 4
2	3 to 5	2 to 7	3 to 6
3	5 to 7	3 to 9	5 to 8
4	7 to 9	5 to 10	7 to 10
5	9 to 11	6 to 11	9 to 12
6	10 to 12	7 to 12	10 to 13
7	10 to 13	8 to 13	10 to 14
8	11 to 14	9 to 14	10 to 15
9	12 to 15	10 to 15	10, 12 to 16
10	12 to 16	10 to 15	11, 13 to 17
11	13 to 16	10, 12 to 16	11, 14 to 18
12	13 to 16	10, 12 to 16	12, 14 to 18
13	14 to 17	10, 12 to 16	12, 14 to 18
14	14 to 17	11, 13 to 17	12, 14 to 18
15	15 to 18	11, 13 to 17	13, 15 to 18
16	16 to 19	11, 13 to 17	13, 15 to 19
17	16 to 19	12, 14 to 18	14, 16 to 19
18	17 to 20	12, 14 to 18	14, 16 to 20
19	18 to 21	13, 15 to 19	15, 17 to 21
20	19 to 22	14, 16 to 20	15, 17 to 21
21	20 to 23	15, 17 to 21	14, 15, 18, 20 to 22
22	21 to 24	16, 18 to 22	15, 16, 19, 21 to 23
23	17, 18, 23 to 25	17, 19 to 23	16, 17, 20, 22 to 24
24	18, 19, 24 to 26	18, 20 to 24	17, 18, 21, 23 to 25
25	19, 20, 25 to 27	19, 21 to 25	18, 19, 22, 24 to 26
26	20, 21, 26 to 28	20, 22 to 26	19, 20, 23, 25 to 27
27	21, 22, 27, 28	21, 23 to 27	20, 21, 24, 26 to 28
28	23, 24, 28, 29	23, 25 to 29	21, 22, 27 to 30
29	24, 25, 28 to 30	24, 26 to 30	22, 23, 27 to 30
30	25, 26, 28 to 30	24, 26 to 30	24, 25, 27 to 30

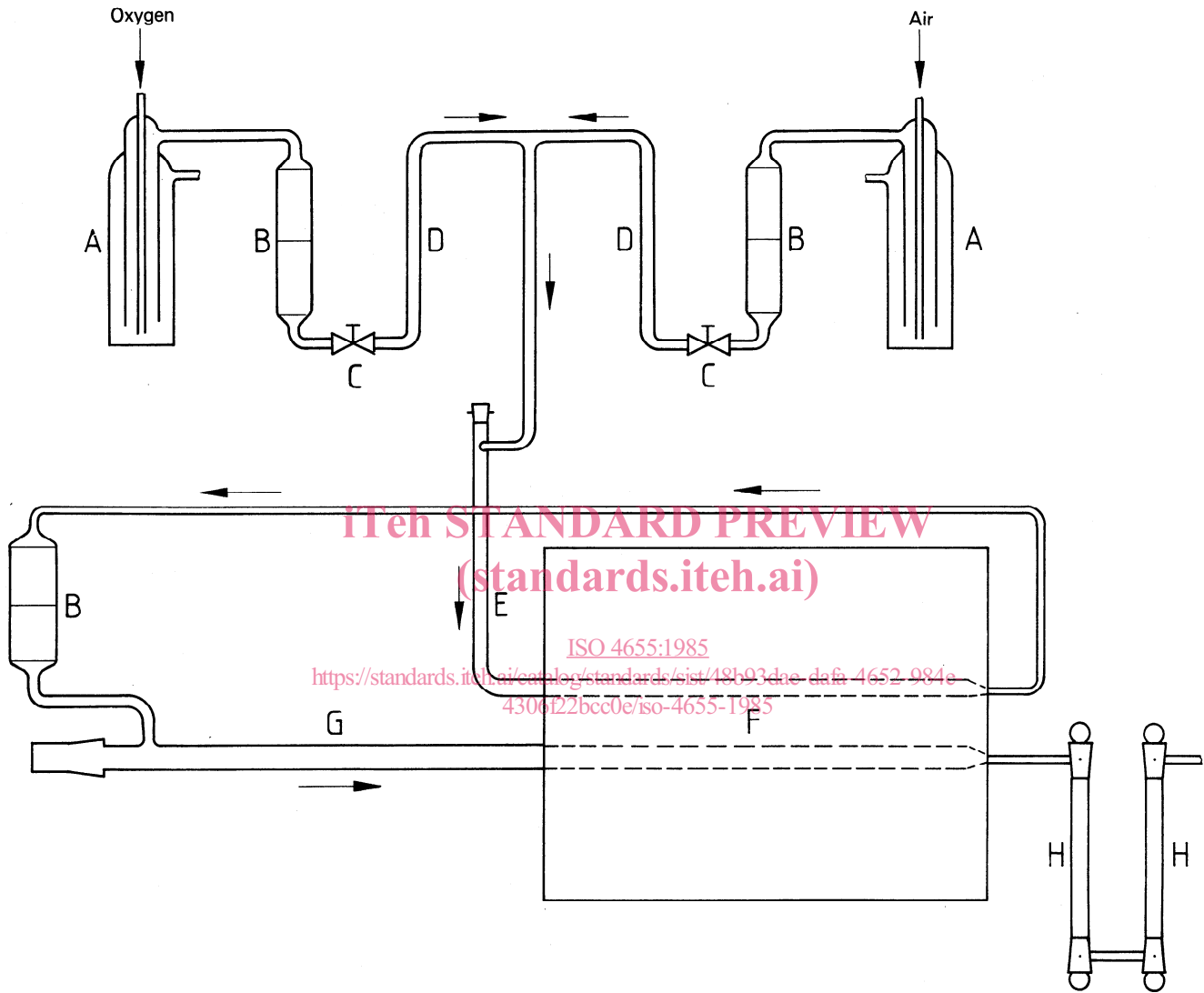

- | | |
|----------------------------|---------------------|
| A Pressure-release vessels | E Purification tube |
| B Guard tubes | F Furnace |
| C Needle valves | G Combustion tube |
| D Rotameters | H Absorption tubes |

Figure 1 – Arrangement of combustion apparatus for carbon/hydrogen method

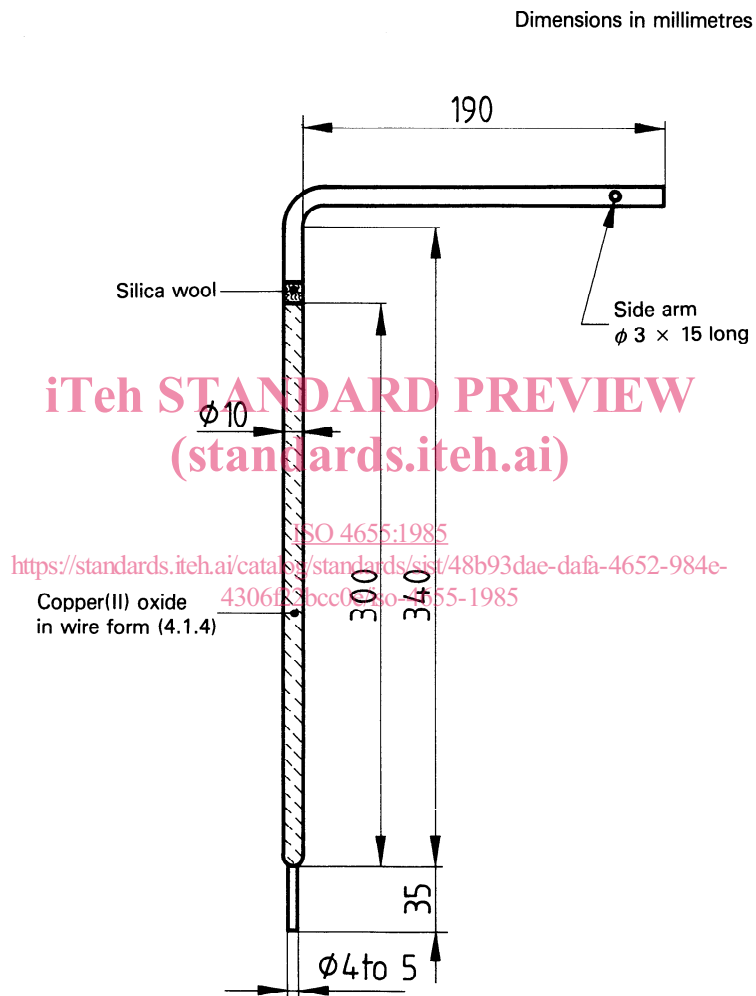

Figure 2 — Purification tube for carbon/hydrogen method