



Designation: F837M – 20

Standard Specification for Stainless Steel Socket Head Cap Screws [Metric]¹

This standard is issued under the fixed designation F837M; the number immediately following the designation indicates the year of original adoption or, in the case of revision, the year of last revision. A number in parentheses indicates the year of last reapproval. A superscript epsilon (ϵ) indicates an editorial change since the last revision or reapproval.

1. Scope*

1.1 This specification covers the chemical and mechanical requirements for stainless steel metric socket head cap screws (SHCS) with nominal thread M1.6 through M36 and intended for use in applications requiring general corrosion resistance.

1.2 Two groups of stainless steel alloys are covered, austenitic Grade A1 and martensitic Grade C1.

1.3 Four property classes are covered: austenitic A1-50 in an annealed condition at 585 MPa maximum; austenitic A1-55 in a cold worked condition at 550 MPa minimum; austenitic A1-70 in a cold worked condition at 700 MPa minimum, and martensitic C1-110 in a heat treated condition at 1100 MPa minimum.

1.4 The values stated in SI units are to be regarded as standard. No other units of measurement are included in this standard.

1.5 This hazard statement pertains only to Section 13, Test Methods: *This standard does not purport to address all of the safety concerns, if any, associated with its use. It is the responsibility of the user of this standard to establish appropriate safety, health, and environmental practices and determine the applicability of regulatory limitations prior to use.*

1.6 *This international standard was developed in accordance with internationally recognized principles on standardization established in the Decision on Principles for the Development of International Standards, Guides and Recommendations issued by the World Trade Organization Technical Barriers to Trade (TBT) Committee.*

2. Referenced Documents

2.1 *ASTM Standards:*²

[A262 Practices for Detecting Susceptibility to Intergranular Attack in Austenitic Stainless Steels](#)

¹ This specification is under the jurisdiction of ASTM Committee F16 on Fasteners and is the direct responsibility of Subcommittee F16.04 on Nonferrous Fasteners.

Current edition approved May 1, 2020. Published May 2020. Originally published as F837M – 83. Last previous edition approved in 2016 as F837M – 16. DOI: 10.1520/F0837M-20.

² For referenced ASTM standards, visit the ASTM website, www.astm.org, or contact ASTM Customer Service at service@astm.org. For *Annual Book of ASTM Standards* volume information, refer to the standard's Document Summary page on the ASTM website.

[A342/A342M Test Methods for Permeability of Weakly Magnetic Materials](#)

[A380/A380M Practice for Cleaning, Descaling, and Passivation of Stainless Steel Parts, Equipment, and Systems](#)

[A751 Test Methods, Practices, and Terminology for Chemical Analysis of Steel Products](#)

[A967/A967M Specification for Chemical Passivation Treatments for Stainless Steel Parts](#)

[D3951 Practice for Commercial Packaging](#)

[E18 Test Methods for Rockwell Hardness of Metallic Materials](#)

[E92 Test Methods for Vickers Hardness and Knoop Hardness of Metallic Materials](#)

[E384 Test Method for Microindentation Hardness of Materials](#)

[F606M Test Methods for Determining the Mechanical Properties of Externally and Internally Threaded Fasteners, Washers, and Rivets \(Metric\)](#)

[F738M Specification for Stainless Steel Metric Bolts, Screws, and Studs \(Withdrawn 2014\)³](#)

[F1470 Practice for Fastener Sampling for Specified Mechanical Properties and Performance Inspection](#)

2.2 *ISO Standard:*⁴

[ISO 4762 Hexagon socket head cap screws](#)

3. Classification

3.1 The designation of the property class for the two materials and conditions of this specification shall be consistent with the stainless steel designations in Specification [F738M](#).

3.2 The austenitic stainless steel socket head cap screw shall be designated F837M A1-50, F837M A1-55, or F837M A1-70.

3.3 The martensitic stainless steel socket head cap screw shall be designated F837M C1-110.

4. Ordering Information

4.1 Orders for socket head cap screws under this specification shall include:

4.1.1 Quantity (number of pieces of each item),

³ The last approved version of this historical standard is referenced on www.astm.org.

⁴ Available from International Organization for Standardization (ISO), ISO Central Secretariat, BIBC II, Chemin de Blandonnet 8, CP 401, 1214 Vernier, Geneva, Switzerland, <http://www.iso.org>.

*A Summary of Changes section appears at the end of this standard

- 4.1.2 Name of the item (socket head cap screws, SHCS),
- 4.1.3 Size (nominal diameter, thread pitch, thread class, screw length) or part number,
- 4.1.4 Property class (A1-50, A1-55, A1-70, or C1-110),
- 4.1.5 ASTM specification and date of issue. When date of issue is not specified, fasteners shall be furnished to the latest issue,
- 4.1.6 Supplementary requirements, if any (see S1 through S3),
- 4.1.7 Additional special requirements, if any, to be specified on the purchase order:
 - 4.1.7.1 Forming (see 5.1),
 - 4.1.7.2 Threading (see 5.2),
 - 4.1.7.3 Surface finish (see 11.1),
 - 4.1.7.4 Alloy selection (see 7.2),
 - 4.1.7.5 Test report (see 11.2),
 - 4.1.7.6 Additional testing (see section 12.3),
 - 4.1.7.7 Inspection (see 13.1),
 - 4.1.7.8 Rejection (see 14.1), and
 - 4.1.7.9 Certification (see 15.1).
 - 4.1.7.10 Special packaging requirements (see section 18.1.2).

5. Material and Manufacture

5.1 *Forging*—Unless otherwise specified, screws in sizes M3 through M20 with lengths up to 10 times the nominal product diameter or 150 mm, whichever is shorter, shall be cold headed except that they may be hot headed or machined by agreement with the purchaser. Larger sizes and lengths may be cold or hot headed. Screws smaller and larger than the M3 through M36 range may be machined. Sockets may be forged or machined at the option of the manufacturer.

5.2 *Threads*—Unless otherwise specified, screws in sizes up to M24 inclusive and product lengths up to 150 mm inclusive shall have threads formed by rolling, except by special agreement with the purchaser. Larger products may be rolled, cut, or ground at the option of the manufacturer.

6. Heat Treatment

6.1 Austenitic alloys class A1-50 screws, following manufacture, shall be annealed by heating to 1040 ± 30 °C to obtain maximum corrosion resistance and minimum permeability. The screws shall be held for a sufficient time at

temperature and then cooled at a rate sufficient to prevent precipitation of the carbide and to provide the properties specified in **Table 1**.

6.2 When Condition A1-55 or A1-70 is specified, the austenitic alloys shall be annealed as specified in 6.1 generally by the raw material manufacturer, then cold worked to develop specific properties.

6.3 Martensitic alloy Class C1 110 screws shall be hardened and tempered by heating to 1010 ± 30 °C sufficient for austenitization, holding for at least ½ h, rapid air or oil quenching, reheating to 275 °C minimum and holding for at least 1 h and then air cooling to provide the properties specified in **Table 1**.

7. Chemical Composition

7.1 It is the intent of this specification that screws shall be ordered by property class. The chemical composition of the screw material shall conform to the requirements of **Table 2**.

7.2 Unless otherwise specified in the inquiry and purchase order (see Supplementary Requirement S2) when A1-50, A1-55, or A1-70 property class is specified, the choice of alloy used by the manufacturer shall be clearly identified on all certification required in the purchase order. The chemical composition shall conform to the limits specified in **Table 2**.

7.3 When chemical analysis is performed by the purchaser using finished fasteners representing each lot, the chemical contents obtained shall conform to the limits specified in **Table 2** for the specific alloy. Chemical contents shall conform to the tolerances specified in Specification A751.

7.3.1 In the event of discrepancy, a referee analysis as specified in 13.1 of samples for each lot shall be made in accordance with 12.3.1.1.

8. Mechanical Properties

8.1 Screws shall be tested in accordance with the mechanical testing requirements for the property class, nominal thread diameter, length, and specified minimum tensile strength as specified in **Table 3** and shall meet the mechanical requirements specified for that product in **Table 1**.

8.2 For products on which both hardness and tension tests are performed, acceptance based on tensile requirements shall take precedence over low hardness readings (see **Table 4**).

TABLE 1 Mechanical Property Requirements

Property Class	Nominal Thread Diameter ^A	Full Size Product Tests		Machined Specimen Tests			Core Hardness ^B	
		Tensile Strength, MPa	Minimum Extension ^C	Tensile Strength, MPa	Yield Strength, MPa	Elongation, %	Vickers	Rockwell
A1-50	M1.6 to M36	585 max	0.6D	585 max	380 max	40	210 max	95 HRB max
A1-55	M1.6 to M20	550 min	0.4D	550 min	270 min	25	160 min	50 HRA min
A1-70	M1.6 to M20	700 min	0.4D	600 min	450 min	20	220 min	59 HRA min
C1-110	M1.6 to M5	1100	350-440	36-45 HRC
	M6 to M36	1100	0.2 D	1100	820	12	350-440	36-45 HRC

^A For A1-55 and A1-70 property class fasteners with nominal thread diameter larger than M20, the mechanical properties shall be agreed upon between the user and manufacturer.

^B Core hardness is only required when full-size product tensile testing cannot be accomplished.

^C D denotes nominal thread size.

TABLE 2 Chemical Requirements

Property Class	UNS Designation	Alloy	Composition, % maximum except as shown, ellipses indicate no requirement for listed element								
			Carbon	Manganese	Phosphorus	Sulfur	Silicon	Chromium	Nickel	Copper	Molybdenum
Austenitic Alloys											
A1	S30300	303 ^A	0.15	2.00	0.20	0.15 min	1.00	17.0 to 19.0	8.0 to 10.0	...	0.60 ^B
A1	S30400	304	0.08	2.00	0.045	0.030	1.00	18.0 to 20.0	8.0 to 10.5	C	...
A1	S30403	304L	0.030	2.00	0.045	0.030	1.00	18.0 to 20.0	8.0 to 12.0	C	...
A1	S30500	305	0.12	2.00	0.045	0.030	1.00	17.0 to 19.0	10.0 to 13.0	C	...
A1	S38400	384	0.08	2.00	0.045	0.030	1.00	15.0 to 17.0	17.0 to 19.0
A1	S20300	XM1 ^A	0.08	5.0 to 6.5	0.040	0.18 to 0.35	1.00	16.0 to 18.0	5.0 to 6.5	1.75 to 2.25	0.50 ^B
A1	S30430	18-9LW	0.10	2.00	0.045	0.030	1.00	17.0 to 19.0	8.0 to 10.0	3.00 to 4.00	...
A1	S30433	302HQ	0.03	2.00	0.045	0.030	1.00	17.0 to 19.0	8.0 to 10.0	3.0 to 4.0	...
A1	S31600	316	0.08	2.00	0.045	0.030	1.00	16.0 to 18.0	10.0 to 14.0	...	2.0 to 3.0
A1	S31603	316L	0.03	2.00	0.045	0.030	1.00	16.0 to 18.0	10.0 to 14.0	...	2.0 to 3.0
Martensitic Alloys											
C1	S41000	410	0.15	1.00	0.040	0.030	1.00	11.5 to 13.5

^A Free machining grades are not recommended for forged product. These grades may be furnished only when approved by the purchaser.

^B At manufacturer's option, determined only when intentionally added.

^C 1.00 % Cu max allowed by this standard for formability at manufacturer's option.

TABLE 3 Mechanical Testing Requirements

Item	Product Length	Hardness		Test conducted Using Full Size Product		Test Conducted Using Machined Test Specification		
		max	min	Extension	Axial Tensile Strength	Yield Strength 0.2 % offset	Tensile Strength	Elongation
1	≤3 D ^A	B	B
2	3 D to 300 mm	B	...	B	B
3	Over 300 mm	B	...	A	A	B	B	B

^A D denotes nominal diameter of product.

^B Denotes mandatory test. In addition, either all tests denoted by A or all tests denoted by B shall be performed. In case of arbitration, full-size tests, denoted A, shall be decisive.

9. Corrosion Resistance

9.1 Carbide Precipitation:

9.1.1 Rod, bar, and wire in the austenitic alloy group A1 (not including the free-machining grade 303) used to make fasteners in accordance with this specification shall be capable of passing the test for susceptibility to intergranular corrosion as specified in Practice E of Practices A262.

9.1.2 As stated in Practices A262, samples may be subjected to the faster and more severe screening test in accordance with Practice A. Failing Practice A, specimens shall be tested to Practice E and be considered satisfactory if passing Practice E.

10. Dimensions

10.1 Unless otherwise specified, the products shall conform to the requirements of ISO 4762 Hexagon socket head cap screws.

11. Workmanship, Finish, and Appearance

11.1 Surface Treatment—Unless otherwise specified, screws shall be cleaned, descaled and passivated in accordance with Practice A380/A380M or Specification A967/A967M at the option of the manufacturer.

11.2 The surface discontinuities for these products shall conform to Specification F1470 and the additional limitations specified herein.

11.2.1 Forging defects that connect the socket to the periphery of the head are not permissible. Defects originating on the periphery and with a traverse indicating a potential to intersect are not permissible. Other forging defects are permissible provided those located in the bearing area, fillet, and top surfaces shall not have a depth exceeding 0.03 D or 0.13 mm, whichever is greater. For peripheral discontinuities, the maximum depth may be 0.06 D (see Fig. 1).

11.2.2 Forging defects located in the socket wall within 0.1 times the actual key engagement, T, from the bottom of the socket are not permissible. Discontinuities located elsewhere in the socket shall not have a length exceeding 0.25 T, or a maximum depth of 0.03 D not to exceed 0.13 mm (see Fig. 2).

11.2.3 Seams in the shank shall not exceed a depth of 0.03 D or 0.2 mm, whichever is greater.

11.2.4 No transverse discontinuities shall be permitted in the head-to-shank fillet area.

11.2.5 Threads shall have no laps at the root or on the flanks, as shown in Fig. 3. Laps are permitted at the crests (Fig. 3c)

TABLE 4 Tensile Strength Values for Full Size Fasteners, kN

Nominal Size and Thread Pitch	Stress Area, mm ² ^A	Property Classes			
		A1-50	A1-55	A1-70	C1-110
		Tensile Strength, kN ^B	Tensile Strength, kN ^C	Tensile Strength, kN ^D	Tensile Strength, kN ^E
M1.6 × 0.35	1.27	0.74	0.70	0.89	1.40
M2 × 0.4	2.07	1.21	1.14	1.45	2.28
M2.5 × 0.45	3.39	1.98	1.87	2.37	3.73
M3 × 0.5	5.03	2.94	2.77	3.52	5.53
M3.5 × 0.6	6.78	3.97	3.73	4.75	7.46
M4 × 0.7	8.78	5.14	4.83	6.15	9.66
M5 × 0.8	14.2	8.30	7.80	9.93	15.6
M6 × 1	20.1	11.8	11.1	14.1	22.1
M8 × 1.25	36.6	21.4	20.1	25.6	40.3
M10 × 1.5	58.0	33.9	31.9	40.6	63.8
M12 × 1.75	84.3	49.3	46.3	59.0	92.7
M14 × 2	115	67.5	63.5	80.8	126.5
M16 × 2	157	91.7	86.2	110	173
M20 × 2.5	245	143	135	171	270
M24 × 3	353	206	388
M30 × 3.5	561	328	617
M36 × 4	817	478	899

^A Stress Area = 0.7854 (D - 0.9382P)²

where:

D = nominal thread diameter, mm, and

P = thread pitch, mm.

^B Tensile based on stress area and 585 MPa maximum.

^C Tensile based on stress area and 550 MPa minimum through M20

^D Tensile based on stress area and 700 MPa minimum through M20.

^E Tensile based on stress area and 1100 MPa minimum.

that do not exceed 25 % of the basic thread depth, and on the flanks outside the pitch cylinder. Longitudinal seams rolled beneath the root of the thread and across the crests of cut threads are acceptable within the limits of 11.2.3.

12. Number of Tests

12.1 The requirements of this specification shall be met in continuous mass production for stock and the manufacturer shall make sample inspections to ensure that the product conforms to the specified requirements. Additional tests of individual shipments of fasteners are not ordinarily necessary. A record of the individual heat of steel in each lot shall be maintained. The containers shall be coded to permit identification of the lot.

12.2 When specified in the purchase order, the manufacturer shall furnish a test report of the last complete set of chemical analysis and mechanical tests for each stock size in each shipment.

12.3 When tests of individual shipments are required, Supplementary Requirement S1 must be specified in the inquiry and order.

12.3.1 When the purchaser does not specify the sampling plan and basis of acceptance, the following shall apply:

12.3.1.1 The lot, for purposes of selecting samples, shall consist of all products offered for inspection and testing, at one

time, that are the same type, style, nominal diameter, thread pitch, nominal length, material (alloy), property class, and surface finish.

12.3.1.2 From each lot, samples shall be selected at random and tested for each requirement in accordance with the following plan:

Number of Pieces in Lot	Number of Samples
800 and less	1
Over 800 to 8000, incl	2
Over 8000 to 22 000, incl	3
Over 22 000	5

12.3.1.3 Should any sample fail to meet the requirements of a specified test, double the number of samples from the same lot shall be retested for the requirement(s) in which it failed. All of the additional samples shall conform to the specification or the lot shall be rejected.

12.3.1.4 If the failure of a test specimen is due to improper preparation of the specimen or an incorrect testing technique, the specimen shall be discarded and another test specimen submitted.

12.4 Corrosion Resistance Tests:

12.4.1 Unless otherwise specified, inspection for corrosion resistance shall be in accordance with the manufacturer's standard quality control practices. No specific method of inspection is required but the screws shall be produced from suitable raw material and manufactured by properly controlled practices to maintain resistance to corrosion. When corrosion tests are required, Supplementary Requirement S5 must be specified in the inquiry and order, except as noted in 12.4.2.

12.4.2 Products that have been hot worked shall be solution annealed and tested to determine freedom from precipitated carbides. Not less than one corrosion test shall be made from each lot. Corrosion tests shall be performed in accordance with Practices A262, Practices A or E as applicable.

13. Test Methods

13.1 *Chemical Analysis*—The chemical composition shall be determined in accordance with Test Method A751.

13.1.1 The fastener manufacturer may accept the chemical analysis of each heat of raw material purchased and reported on the raw material certification furnished by the raw material producer. The fastener manufacturer is not required to do any further chemical analysis testing provided that precise heat lot traceability has been maintained throughout the manufacturing process on each lot of fasteners produced and delivered.

13.2 Mechanical Tests:

13.2.1 Screws tested full size for axial strength, screw extension, and hardness shall be tested in accordance with the methods described in Test Methods F606M and 13.2.3 of this specification. The hardness shall be determined using Test Methods E18, E92, or E384, as appropriate.

13.2.2 Machined test specimens tested for tensile strength, yield strength at 0.2 % offset, and elongation shall be tested in accordance with the methods described in Test Methods F606M.

13.2.3 Extension Test is applicable only to full size products. The overall length of the test specimen (L₁) shall be measured within ±0.12 mm. The head end reference surface

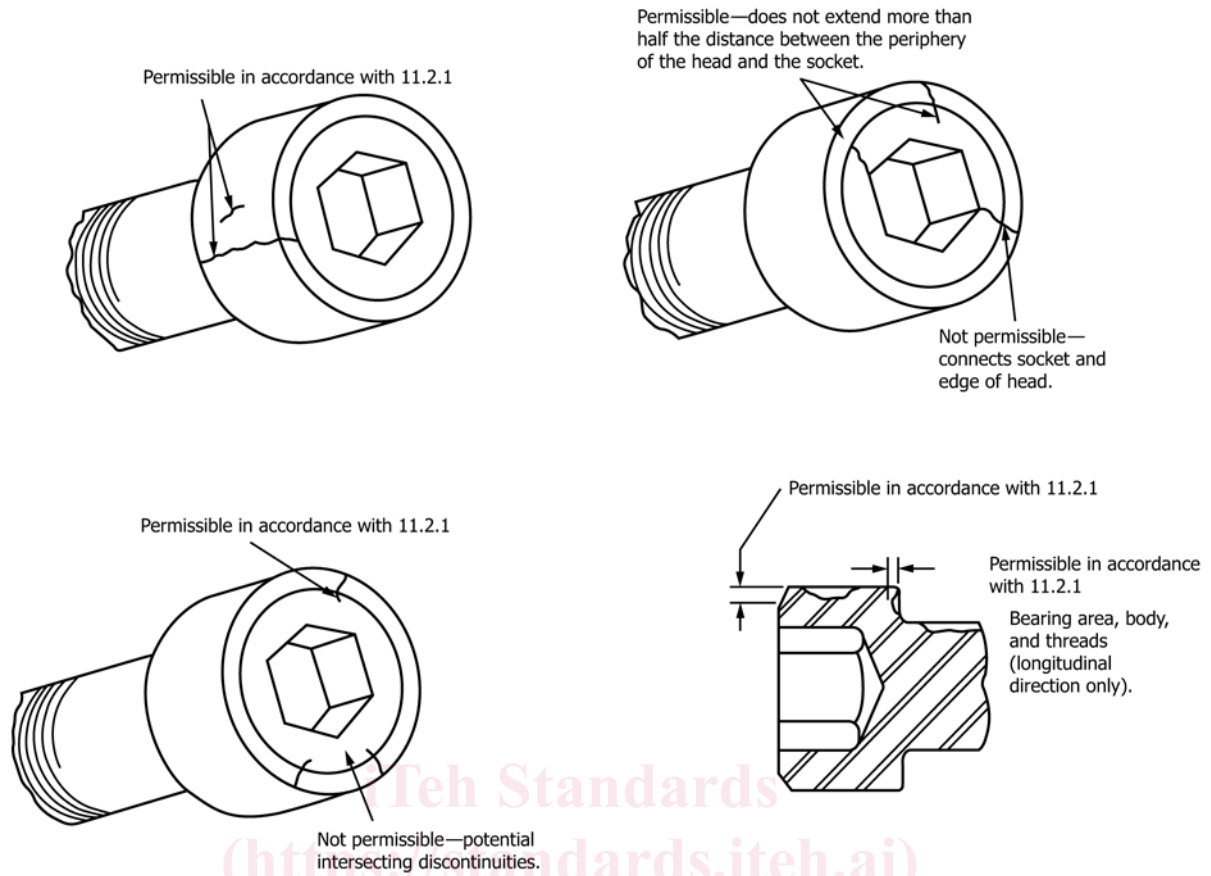

FIG. 1 Head and Body Discontinuity Location and Limits

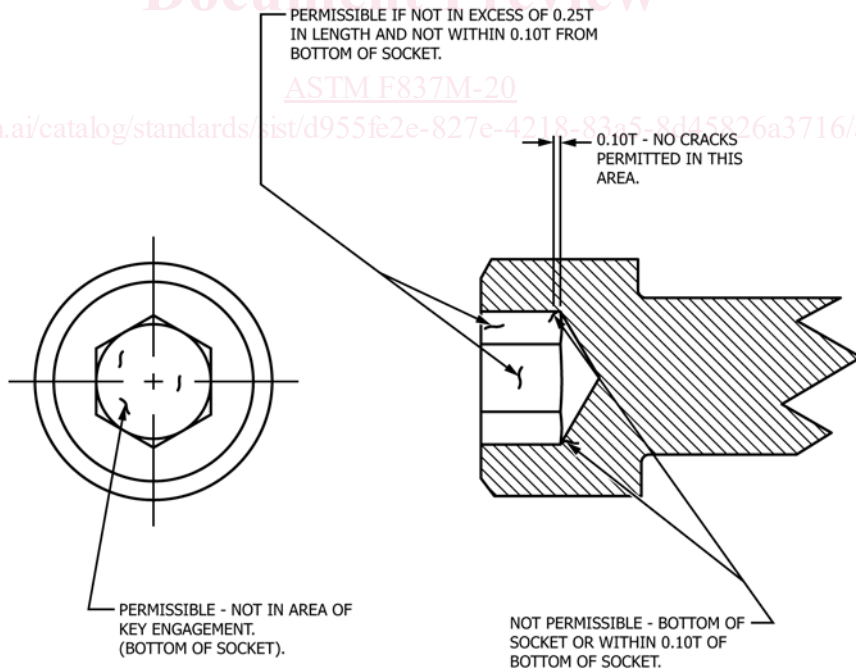

FIG. 2 Socket Discontinuity Location and Limits

for length measurement may be the bottom of the hex socket for measuring purposes. The specimen shall be assembled into a threaded adapter to a depth of one nominal diameter and then

axial tensile tested in accordance with 13.2.1 to failure. The two broken pieces shall be fitted closely together and the overall length (L_2) measured again. The total extension shall be