



Designation: C651 – 20

Standard Test Method for Flexural Strength of Manufactured Carbon and Graphite Articles Using Four-Point Loading at Room Temperature¹

This standard is issued under the fixed designation C651; the number immediately following the designation indicates the year of original adoption or, in the case of revision, the year of last revision. A number in parentheses indicates the year of last reapproval. A superscript epsilon (ϵ) indicates an editorial change since the last revision or reapproval.

This standard has been approved for use by agencies of the U.S. Department of Defense.

1. Scope*

1.1 This test method covers determination of the flexural strength of manufactured carbon and graphite articles using a simple beam in four-point loading at room temperature.

1.2 The values stated in SI units are to be regarded as standard. No other units of measurement are included in this standard.

1.3 *This standard does not purport to address all of the safety concerns, if any, associated with its use. It is the responsibility of the user of this standard to establish appropriate safety, health, and environmental practices and determine the applicability of regulatory limitations prior to use.*

1.4 *This international standard was developed in accordance with internationally recognized principles on standardization established in the Decision on Principles for the Development of International Standards, Guides and Recommendations issued by the World Trade Organization Technical Barriers to Trade (TBT) Committee.*

2. Referenced Documents

2.1 *ASTM Standards:*²

[C78 Test Method for Flexural Strength of Concrete \(Using Simple Beam with Third-Point Loading\)](#)

[C1161 Test Method for Flexural Strength of Advanced Ceramics at Ambient Temperature](#)

[E4 Practices for Force Verification of Testing Machines](#)

[E177 Practice for Use of the Terms Precision and Bias in ASTM Test Methods](#)

[E691 Practice for Conducting an Interlaboratory Study to Determine the Precision of a Test Method](#)

¹ This test method is under the jurisdiction of ASTM Committee D02 on Petroleum Products, Liquid Fuels, and Lubricants and is the direct responsibility of Subcommittee D02.F0 on Manufactured Carbon and Graphite Products.

Current edition approved May 1, 2020. Published May 2020. Originally approved in 1970. Last previous edition approved in 2015 as C651 – 15. DOI:10.1520/C0651-20.

² For referenced ASTM standards, visit the ASTM website, www.astm.org, or contact ASTM Customer Service at service@astm.org. For *Annual Book of ASTM Standards* volume information, refer to the standard's Document Summary page on the ASTM website.

3. Terminology

3.1 *Definitions:*

3.1.1 *flexural strength, n*—a measure of the ultimate load carrying capacity of a specified beam in bending.

4. Significance and Use

4.1 This test method may be used for material development, quality control, characterization, and design data generation purposes.

4.2 This test method determines the maximum loading on a graphite specimen with simple beam geometry in 4-point bending, and it provides a means for the calculation of flexural strength at ambient temperature and environmental conditions.

5. Apparatus

5.1 The testing machine shall conform to the requirements of Practices E4.

5.2 The four-point loading fixture shall consist of bearing blocks or cylindrical bearings spaced in a third-point loading configuration (see Test Method C78).

5.3 The fixture shall ensure that forces applied to the beam are normal only and without eccentricity through the use of spherical bearing blocks (see Test Method C78) or articulating roller bearing assemblies (see Test Method C1161).

5.3.1 The bearing block or roller bearing diameter shall be between $\frac{1}{10}$ and $\frac{1}{20}$ of the specimen support span. A hardened steel bearing block or its equivalent is necessary to prevent distortion of the loading member. Support surfaces must be free to pivot or rotate to relieve frictional constraints.

5.4 The directions of loads and reactions may be maintained parallel by judicious use of linkages, rocker bearings, and flexure plates. Eccentricity of loading can be avoided by the use of spherical bearing blocks or articulating roller bearings. Provision must be made in fixture design for the relief of torsional loading to less than 5 % of the nominal specimen strength. Refer to the attached figure for a suggested four-point loading fixture.

*A Summary of Changes section appears at the end of this standard

6. Test Specimen

6.1 *Preparation*—The test specimen shall be prepared to yield a parallelepiped of rectangular cross section. The faces shall be parallel and flat within 0.025 mm/mm of length. In addition, the samples having a maximum particle size less than 0.150 mm in diameter must be finished so that the surface roughness is less than 3 μm Ra. Sample edges should be free from visible flaws and chips.

NOTE 1—For ease of machining to conventional standards, 3 μm Ra is equivalent to 125 μin . AA. For finishing of specimens with maximum particle sizes of greater than 0.150 mm, grain structure and porosity can limit the accurate measurement of roughness. In these cases, the surface roughness should be visually equivalent to 3 μm Ra as estimated based on the visible surface of the graphite.

6.2 *Size*—The size of the test specimen shall be selected such that the minimum dimension of the specimen is greater than 5 times the largest particle dimension. The test specimen shall have a length to thickness ratio of at least 8, and a width to thickness ratio not greater than 2.

6.3 *Measurements*—All dimensions shall be measured to the nearest 0.5 %.

6.4 *Orientation*—The specimen shall be marked or otherwise identified to denote its orientation with respect to the parent stock.

6.5 *Drying*—Each specimen must be dried in a vented oven at 120 °C to 150 °C for a period of 2 h. The sample must then be stored in a dry environment or a desiccator and held there prior to testing.

NOTE 2—Water, either in the form of liquid or as humidity in air, can have an effect on flexural mechanical behavior. Excessive adsorbed water can result in a reduced failure stress due to a decrease in fracture surface energy.

7. Procedure

7.1 Center the load applying bearing surfaces and the test specimen on the support bearing surfaces. The load span is at least two times the sample thickness, and the support span three times the load span, but not less than 40 mm. The load and support bearings shall be carefully positioned such that the spans are accurate to within 0.5 %. Overlap each end of the specimen by at least the specimen thickness. Refer to Fig. 1.

7.2 The load applying bearing surfaces shall make contact with the upper surface of the test specimen. Load and support bearing blocks must be parallel to each other and perpendicular to the test surfaces. Use a loading rate of 1.25 mm/min or less on screw-driven testing machines. On other test devices, load the part at a uniform rate such that breakage occurs in 5 s or more.

8. Test Data Record

8.1 Measurements to 0.025 mm shall be made to determine the average width and thickness of the specimen.

8.2 The load at failure must be recorded to an accuracy of ± 2 % of the full-scale value. A full-scale value of 5 kN would require recording to an accuracy of ± 100 N.

9. Calculation

9.1 If the fracture occurs within the span length between the load bearing surfaces (that is, within the load span), calculate the flexural strength as follows:

$$S = PL/bd^2$$

where:

S = flexural strength, MPa,
 P = maximum applied load indicated by the testing machine, N,
 L = support span length, mm,
 b = average width of specimen, mm, and
 d = average thickness of specimen, mm.

9.2 If the fracture occurs outside of the span length between load bearing blocks, the location of the fracture shall be recorded as such, and the results of the test shall be reported. Occasional breaks outside the inner load span in 4-point flexure are not unusual, and can often be attributed to large natural flaws in the material.

NOTE 3—Angular fractures that effectively traverse the load roller contact point but are determined to have initiated at or inside of the load roller span can be reasonably attributed to failure at the maximum flexure stress, and should be recorded as having fractured inside of the span length between the load roller blocks.

9.3 If fracture occurs in less than 5 s, the results shall be discarded but reported.

9.4 An alternative calculation for flexural strength can be used if the span length between the load bearing surfaces is not accurately measured to three times the load span:

$$S = 3 Pa/bd^2 \quad (1)$$

where:

a = distance between the load and support roller, mm.

NOTE 4—It should be recognized that the above equations do not necessarily give the stress that was acting directly on the origin that caused failure. The equations do not account for subsurface origins or breaks outside of the load span, nor do they correct for the potential tension/compression inequality in modulus (behavior that is not linear elastic) commonly accepted in graphite. For conventional Weibull analysis, use the calculated maximum stress in the specimen at failure from the equations as shown.

10. Report

10.1 The report of each test shall include the following:

- 10.1.1 Sample identification,
- 10.1.2 Average width to the nearest 0.025 mm,
- 10.1.3 Average thickness to the nearest 0.025 mm,
- 10.1.4 Support span length, (and load span length if accurate third point loading is not measured), mm,
- 10.1.5 Rate of loading, mm/min,
- 10.1.6 Maximum applied load, N,
- 10.1.7 Flexural strength calculated to the nearest 10 kPa,
- 10.1.8 Defects in specimen,
- 10.1.9 Orientation and location of specimen, and
- 10.1.10 Failure location.

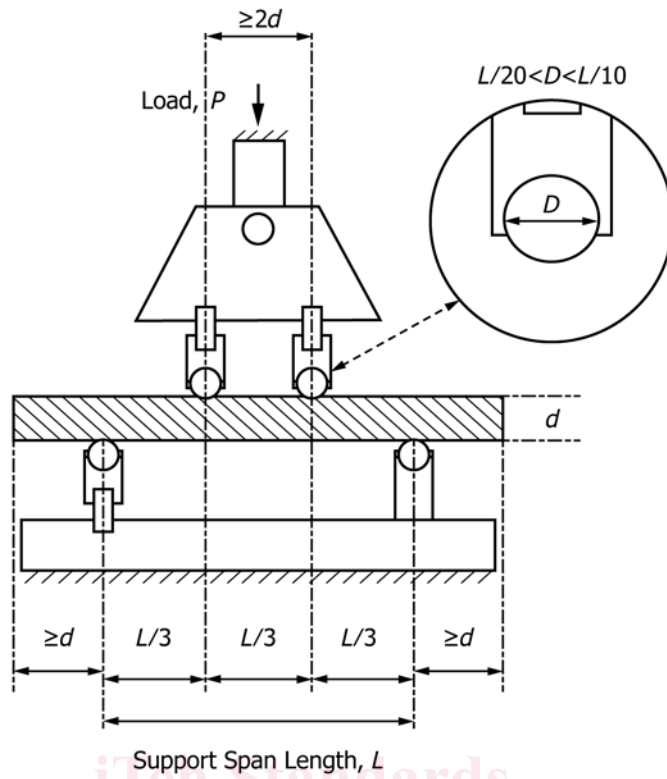

(a)

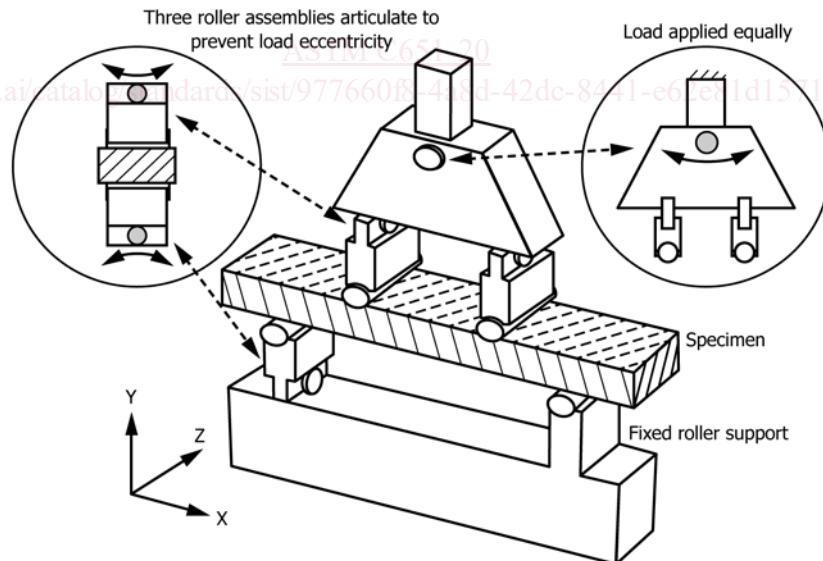

(b)

FIG. 1 Beam with Four-Point Loading