



Designation: **D7109—18 D7109 – 20**

Standard Test Method for Shear Stability of Polymer-Containing Fluids Using a European Diesel Injector Apparatus at 30 Cycles and 90 Cycles¹

This standard is issued under the fixed designation D7109; the number immediately following the designation indicates the year of original adoption or, in the case of revision, the year of last revision. A number in parentheses indicates the year of last reappraisal. A superscript epsilon (ϵ) indicates an editorial change since the last revision or reappraisal.

1. Scope*

1.1 This test method covers the evaluation of the shear stability of polymer-containing fluids. The test method measures the viscosity loss, in mm^2/s and percent, at 100°C of polymer-containing fluids when evaluated by a diesel injector apparatus procedure that uses European diesel injector test equipment. The viscosity loss reflects polymer degradation due to shear at the nozzle. Viscosity loss is evaluated after both 30 cycles and 90 cycles of shearing.

NOTE 1—This test method evaluates the shear stability of oils after both 30 cycles and 90 cycles of shearing. For most oils, there is a correlation between results after 30 cycles and results after 90 cycles of shearing, but this is not universal.

NOTE 2—Test Method **D6278** uses essentially the same procedure with 30 cycles only instead of both 30 cycles and 90 cycles. The correlation between results from this test method at 30 cycles and results from Test Method **D6278** has not been established.

NOTE 3—Test Method **D2603** has been used for similar evaluation of shear stability; limitations are as indicated in the significance statement. No detailed attempt has been undertaken to correlate the results of this test method with those of the sonic shear test method.

NOTE 4—This test method uses test apparatus as defined in CEC L-14-A-93. This test method differs from CEC-L-14-A-93 in the period of time required for calibration.

NOTE 5—Test Method **D5275** also shears oils in a diesel injector apparatus but may give different results.

NOTE 6—This test method has different calibration and operational requirements than withdrawn Test Method D3945.

1.2 The values stated in SI units are to be regarded as standard. The values given in parentheses after SI units are provided for information only and are not considered standard.

1.3 *This standard does not purport to address all of the safety concerns, if any, associated with its use. It is the responsibility of the user of this standard to establish appropriate safety, health, and environmental practices and determine the applicability of regulatory limitations prior to use.* Specific warning statements are given in Section 8.

1.4 *This international standard was developed in accordance with internationally recognized principles on standardization established in the Decision on Principles for the Development of International Standards, Guides and Recommendations issued by the World Trade Organization Technical Barriers to Trade (TBT) Committee.*

2. Referenced Documents

2.1 ASTM Standards:²

[D445 Test Method for Kinematic Viscosity of Transparent and Opaque Liquids \(and Calculation of Dynamic Viscosity\)](#)

[D2603 Test Method for Sonic Shear Stability of Polymer-Containing Oils](#)

[D5275 Test Method for Fuel Injector Shear Stability Test \(FISST\) for Polymer Containing Fluids](#)

[D6278 Test Method for Shear Stability of Polymer Containing Fluids Using a European Diesel Injector Apparatus](#)

[D6299 Practice for Applying Statistical Quality Assurance and Control Charting Techniques to Evaluate Analytical Measurement System Performance](#)

[D7042 Test Method for Dynamic Viscosity and Density of Liquids by Stabinger Viscometer \(and the Calculation of Kinematic Viscosity\)](#)

2.2 Coordinated European Council (CEC) Standard:

[CEC L-14-A-93 Evaluation of the Mechanical Shear Stability of Lubricating Oils Containing Polymers³](#)

¹ This test method is under the jurisdiction of ASTM Committee **D02** on Petroleum Products, Liquid Fuels, and Lubricants and is the direct responsibility of Subcommittee **D02.07** on Flow Properties.

Current edition approved ~~June 1, 2018~~ ~~May 1, 2020~~ ~~August 2018~~ ~~June 2020~~. Originally approved in 2004. Last previous edition approved in 2018 as **D7109—12: D7109 – 18**. DOI: [10.1520/D7109-18:10.1520/D7109-20](#).

² For referenced ASTM standards, visit the ASTM website, [www.astm.org](#), or contact ASTM Customer Service at [service@astm.org](#). For *Annual Book of ASTM Standards* volume information, refer to the standard's Document Summary page on the ASTM website.

³ Available from CEC Secretariat, Interlynk Administrative Services, Ltd., Lynk House, 17 Peckleton Lane, Desford, Leicestershire, LE9 9JU, United Kingdom.

*A Summary of Changes section appears at the end of this standard

3. Terminology

3.1 Definitions:

3.1.1 *kinematic viscosity, n*—a measure of the resistance to flow of a fluid under gravity.

3.2 Definitions of Terms Specific to This Standard:

3.2.1 *calibration pressure, n*—the recorded gauge pressure when calibration fluid RL233 undergoes a viscosity loss of 2.70 mm²/s to 2.90 mm²/s when the recorded gauge pressure is within the range of 13.0 MPa to 18.0 MPa.

3.2.2 *percent viscosity loss, n*—viscosity loss, as defined in 3.2.3, divided by the pre-sheared viscosity, and reported as a percent.

3.2.3 *viscosity loss, n*—the loss in viscosity determined from the difference in kinematic viscosity at 100 °C of pre-sheared and post-sheared fluid.

4. Summary of Test Method

4.1 A polymer-containing fluid is passed through a diesel injector nozzle at a shear rate that may reduce its kinematic viscosity. The percent viscosity loss is a measure of the mechanical shear stability of the fluid.

NOTE 7—This test method may also be used for oils not containing polymer. It might not be known whether an oil submitted for test contains a polymer.

5. Significance and Use

5.1 This test method evaluates the percent viscosity loss of fluids resulting from physical degradation in the high shear nozzle device. Thermal or oxidative effects are minimized.

5.2 This test method may be used for quality control purposes by manufacturers of polymeric lubricant additives and their customers.

5.3 This test method is not intended to predict viscosity loss in field service in different field equipment under widely varying operating conditions, which may cause lubricant viscosity to change due to thermal and oxidative changes, as well as by the mechanical shearing of polymer. However, when the field service conditions, primarily or exclusively, result in the degradation of polymer by mechanical shearing, there may be a correlation between the results from this test method and results from the field.

6. Apparatus

6.1 The apparatus consists of a fluid reservoir, a double-plunger pump with an electric motor drive, an atomization chamber with a diesel injector spray nozzle, and a fluid cooling vessel, installed in an area with an ambient temperature of 20 °C to 25 °C (68 °F to 77 °F). Fig. 1 shows the schematic representation of equipment.⁴

6.1.1 *Fluid Reservoir*—In Fig. 1, the fluid reservoir (7) is open on the top, has approximately a 250 mL capacity with graduation of a maximum of 5 mL, has a 45 mm (1.772 in.) inner diameter, and is calibrated in units of volume. It is fitted with an internal fluid distributor as detailed in Fig. 2. A 40 mm (1.575 in.) diameter watch glass with serrated edges is an acceptable distributor plate. The distributor reduces the tendency of fluid channeling. Temperature is measured by a thermometer suspended in the center of the fluid reservoir. The bottom of the thermometer bulb shall be 10 mm to 15 mm above the entrance to the drain tube opening. Other temperature-measuring equipment positioned at the same location may also be used. The outlet is equipped with a three-way stopcock (8). The three-way stopcock is of a cone type with a nonexchangeable solid plug with an 8 mm (0.315 in.) nominal bore size. Transparent plastic tubing, (10) in Fig. 1, is used to connect the three-way stopcock to the pump inlet.

6.1.2 *Double-Plunger Injection Pump*—In Fig. 1, the injection pump (11) is defined as Bosch PE 2 A 90D 300/3 S2266. This pump is equipped with a stroke counter (15), venting screw (14), and a flow rate adjusting screw (12).

6.1.3 *Injection Pump*, driven by a three-phase electric motor (13) in Fig. 1, rated at a speed of 925 r/min ± 25 r/min.

6.1.3.1 This motor runs at 925 r/min on the 50 Hz current prevalent in Europe; it will run at approximately 1100 r/min on 60 Hz current. The 1100 r/min speed is not acceptable in this procedure. A suitable means shall be taken to ensure the prescribed 925 r/min ± 25 r/min speed to the injection pump. One acceptable method is to use a 6 to 5 speed reducer.

6.1.4 *Outlet of Injection Pump*, connected to the atomization chamber using high pressure steel tubing. The atomization chamber (2) in Fig. 1, is defined in more detail in Fig. 3. To minimize foam generation, the spray chamber is designed so that the fluid under test exits from the nozzle into a chamber filled with the test fluid. A drain tube (17) fitted with a two-way stopcock is included to minimize contamination from the previous test during the system cleaning steps. The diesel injector nozzle is a Bosch DN 8 S 2-type pintle nozzle injector, number 0434 200 012, installed in a Bosch KD 43 SA 53/15 nozzle holder. The nozzle holder includes a filter cartridge.

NOTE 8—Exercise great care to avoid damage to the precision parts of the fuel injection equipment (the plunger and barrel in the pump and the nozzle valve assembly). Service work on the equipment should be performed by a diesel fuel injector pump specialist or with reference to the manufacturer's service manual.⁵

NOTE 9—An unusually rapid rise in gauge pressure during testing may signify filter blockage. When this occurs, the filter cartridge shall be replaced.

⁴ Throughout, the numbers in parentheses refer to the legend in Fig. 1.

⁵ Repair Instructions for Diesel Injection Pumps Size A, B, K and Z, Bulletin WJP 101/1 B EP, Robert Bosch GmbH, 2800 South 25th Ave., Broadview, IL 60153.

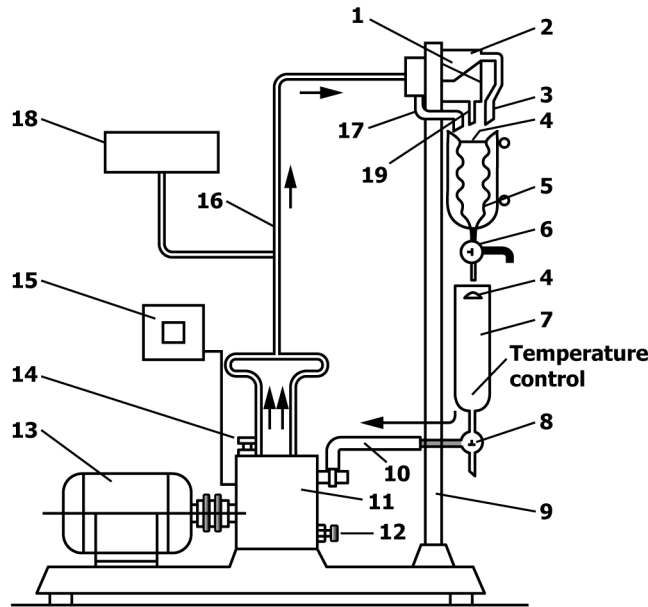

Legend:

(1) Spray nozzle

(1) Spray nozzle

(2) Atomization chamber

(3) Outlet of the atomization chamber

(4) Distributor plate

(5) Fluid-cooling vessel

(6) Three-way cock downstream of glass

(7) Fluid reservoir

(8) Three-way cock downstream of glass container

(9) Support column

(10) Connection with pump-suction opening

(11) Double-plunger injection pump

(12) Pump setting screw

(13) Electric motor

(14) Venting screw/pump

(15) Stroke counter

(16) Pressure tubing from pump to injector

(17) Return line for overflowing liquid

(18) Pressure sensing device

(19) Drain line of atomization chamber

(2) Atomization chamber

(3) Outlet of the atomization chamber

(4) Distributor plate

(5) Fluid-cooling vessel

(6) Three-way cock downstream of glass

(7) Fluid reservoir

(8) Three-way cock downstream of glass container

(9) Support column

(10) Connection with pump-suction opening

(11) Double-plunger injection pump

(12) Pump setting screw

(13) Electric motor

(14) Venting screw/pump

(15) Stroke counter

(16) Pressure tubing from pump to injector

(17) Return line for overflowing liquid

(18) Pressure sensing device

(19) Drain line of atomization chamber

FIG. 1 Apparatus for Shear Stability Testing

6.1.5 *Pressure-sensing Device* (18), such as a glycerol-filled pressure gauge or electronic, digital display pressure indicator, shall be installed and separated from the line by a pressure snubber or needle valve to suitably dampen pressure surges. The

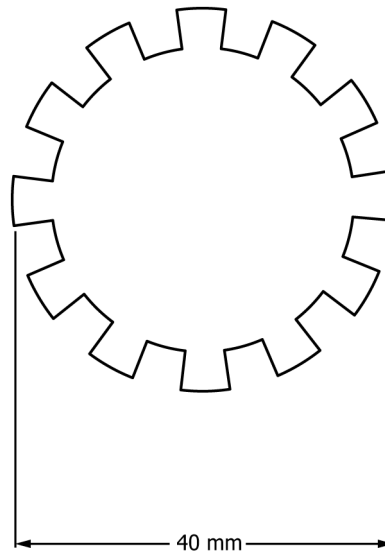

NOTE 1—Dimensions are given in millimeters.

FIG. 2 Distributor Plate

pressure-sensing device shall be able to take readings with a display resolution of at least 0.1 MPa when a glycerol-filled pressure gauge is being used, or to 0.01 MPa when an electronic pressure device is employed. The pressure device shall be occasionally pressure tested to ensure accuracy.

6.1.6 *Fluid Cooling Vessel*, ((5) in Fig. 1), used to maintain the specified temperature of the test fluid, as indicated at the outlet of the fluid reservoir. This vessel is a glass container with exterior cooling jacket constructed so that the heat transfer surface of the jacket is spherical. The exterior jacket diameter, d_1 , is approximately 50 mm (1.969 in.). The interior heat transfer surface, d_2 , is approximately 25 mm (0.984 in.) in diameter. The overall length, L , is approximately 180 mm (7.087 in.). A distributor plate, similar in design to the distributor plate in the fluid reservoir, is positioned in the upper portion of the fluid cooling vessel to ensure contact between the fluid and the cooling surface. The discharge from the fluid cooling vessel is through a three-way stopcock of the same design used on the discharge of the fluid reservoir. If using a rate-dependent chiller, the exterior cooling jacket shall be supplied with an adjustable volume of cold water.

6.2 *Viscometer*—Any viscometer and bath meeting the requirements of Test Method D445 or D7042. Whichever method is chosen, that same method must be used for the before and after samples as well as the calibration samples.

7. Materials

7.1 *Diesel Fuel (No. 2)*, initially required to adjust the diesel injector nozzle valve opening pressure.

7.2 *Calibration Fluid, RL233*, used to ensure that when the apparatus is adjusted within a prescribed pressure range, the correct viscosity loss is obtained.

8. Hazards

8.1 **Warning**—Use a safety shield between the high-pressure components and the operator during use of equipment.

8.2 **Warning**—During operation, the line between the pump and nozzle, ((16) in Fig. 1), is under a pressure of at least 13.0 MPa (130 bar or 1885 psi). Pressures above the upper limit of 18.0 MPa (180 bar or 2611 psi) are possible if filter plugging occurs. Shut off the pump prior to tightening any fitting that is not properly sealed.

9. Sampling

9.1 Approximately 650 mL of fluid is needed per test.

9.2 The test fluid shall be at room temperature, uniform in appearance, and free of any visible insoluble material prior to placing it in the test equipment.

9.3 Water and insolubles shall be removed before testing, or filter blocking and nozzle wear may occur. Filter blocking can be detected by a sudden change in gauge pressure. The transport of insolubles to the shear zone will shorten nozzle life.

10. Calibration and Standardization

10.1 *Nozzle Adjustments*—If the nozzle to be used is new or has not been pre-calibrated, adjust the diesel injector nozzle holder with the nozzle in place. Adjust the nozzle using diesel fuel and a nozzle tester so that the valve opening pressure is 13.0 MPa

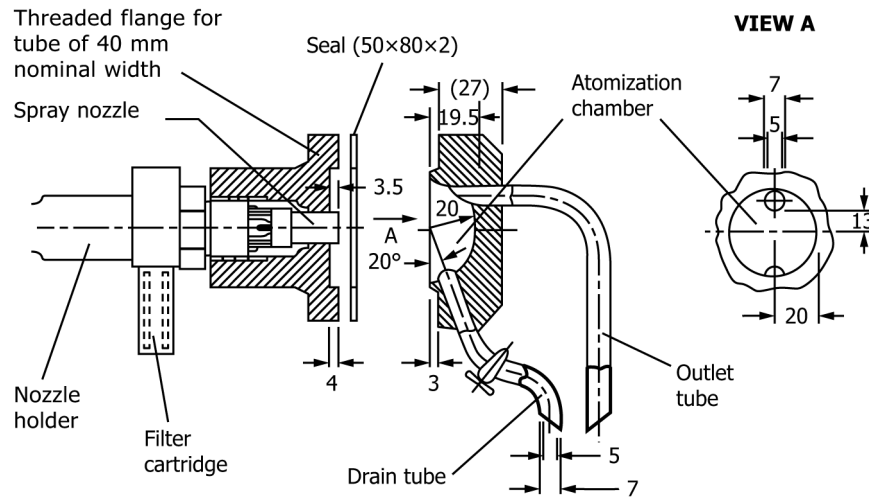

FIG. 3 Atomization Chamber with Spray Nozzle and Nozzle

(1885 psi) under static conditions. If the nozzle has been pre-calibrated with RL233 calibration oil, adjust the valve opening pressure to the calibration pressure prescribed, which must be between 13.0 MPa (1885 psi) and 18.0 MPa (2611 psi).

10.1.1 Install the nozzle and the nozzle holder in the test apparatus. The pintle/spray nozzle shall be tightly fitted in the chamber to avoid leakage of oil around the external surface of the spray nozzle.

10.2 *Measurement of Residual Undrained Volume, V_{res} :*

10.2.1 The residual undrained oil volume of the system is the volume of the system between the three-way stopcock below the fluid reservoir (8) in Fig. 1, and the injector nozzle orifice (1). V_{res} does not include the atomization chamber volume. When the residual undrained volume is known, go to 10.4.

10.2.2 To determine residual undrained volume, first remove as much fluid as possible by briefly running the pump.

10.2.3 Remove the high-pressure lines (16) in Fig. 1, and drain. Remove the plug at the end of the pump gallery to drain the remaining oil in the pump. Drain atomization chamber (2).

10.2.4 Reassemble the system and close all drains. The upper three-way stopcock (6) shall be open to the lower reservoir (7) and the lower three-way cock (8) shall be open to the pump suction (10).

10.2.5 Add 170 mL of RL233 calibration oil to the lower reservoir (7) and observe the level. Start the pump and run for several minutes until the oil is transparent and free of suspended air.

10.2.6 Stop the pump. Drain the fluid in the atomization chamber into a beaker and then pour the fluid back into the lower reservoir; draining to waste will result in an error in the measurement of V_{res} . Allow the system to drain for 20 min and free air trapped in the transparent connecting tube between the lower reservoir and pump.

10.2.7 Observe the difference in oil level in the lower reservoir compared to that noted in 10.2.5. Record this difference as the residual volume, V_{res} .

NOTE 10—Undrained residual volumes of 15 mL to 30 mL have been reported by various users of this test. V_{res} measurements in excess of this may occur when fluid in the atomization chamber is not poured back into the lower reservoir as in 10.2.6, or if the length of line (10) is excessive.

10.2.8 Calculate the run volume, V_{run} , which is the difference between 170 mL and V_{res} , $V_{run} = 170 - V_{res}$.

10.3 *Warm-up*—A half-hour warm-up period is required before proceeding to calibrate with RL233. Set the stroke counter shut-off to 30 times n strokes, and start the pump.

NOTE 11—This warm-up period is only required for the first within-day calibration.

10.4 *Cleaning the Apparatus, Setting the Stroke Counter, and Adjusting the Pump Stroke:*

10.4.1 Drain residual oil by way of drain line (19) from the atomization chamber into a waste container. Drain fluid in the cooling jacket by means of stopcock (6) (Fig. 1) and the fluid reservoir by means of stopcock (8), into suitable waste containers.

10.4.2 After fluid has drained, leave the stopcock on the drain line to the atomization chamber open and the three-way stopcock (6) positioned so that fluid in the cooling jacket drains to a waste container. Position stopcock (8) so that the drain is closed but the fluid reservoir is open to pump suction through line (10). Add a minimum of 50 mL of RL233 to the fluid reservoir.

NOTE 12—Steps 10.4.2 to 10.4.7 are representative of the first and second purges with 50 mL fluid that are needed to remove used oil from the apparatus prior to calibration and testing. For these steps, the stopcock below the atomization chamber and cooling jackets are set so that oil will flow into waste containers.

10.4.3 Free the apparatus of air in the line by use of the venting screw (14), and by manual compression of the transparent flexible tube that connects the pump to the fluid reservoir.

10.4.4 Set the stroke counter so that the pump will run a sufficient length of time to evacuate the fluid out of the fluid reservoir.

10.4.5 Start the pump. Observe the fluid level in the reservoir and stop the pump when all the fluid is out of the base of the reservoir but is still fully-retained in line (10).

10.4.6 Add a minimum of 50 mL of RL233 fluid to the fluid reservoir a second time and operate the pump until the fluid reservoir is empty but line (10) is still filled with fluid.

10.4.7 After all oil has drained, close the stopcock on the atomization chamber drain line (19), position stopcock (6) so that fluid will flow from the cooling jacket into the fluid reservoir.

10.4.8 Remove the thermometer or temperature probe from the fluid reservoir.

NOTE 13—The thermometer and assembly can interfere with the obtainment of accurate volume measurements in the fluid reservoir, hence its removal is called for when the accurate determination of fluid volume is needed. A thermocouple or thermistor probe is a suitable alternative to a thermometer.

10.4.9 Add a minimum amount of fluid equal to the sum of 30 mL plus V_{run} , determined in 10.2.8, to the fluid reservoir.

10.4.10 Close the stopcock below the atomization chamber drain line (19) and position stopcock (6) so that the fluid will drain from the cooling jacket into the fluid reservoir.

NOTE 14—The atomization chamber drain line is always closed for the third cleaning run and all test runs.

10.4.11 Free the apparatus of air in the line by manual compression of the flexible tube (10) that connects the pump to the fluid reservoir. The venting screw (14), is also used for this purpose.

10.4.12 Record the number on the stroke counter, n_1 .

10.4.13 Use a stopwatch or other timing device and run the pump for $1 \text{ min} \pm 1 \text{ s}$. Record new counter value, n_2 .

10.4.14 Determine n , the difference in the stroke count from 10.4.12 and 10.4.13 as follows:

$$n = n_2 - n_1 \quad (1)$$

10.4.15 Set the stroke counter shutoff to the product of three times n . The pump shall run for $3 \text{ min} \pm 3 \text{ s}$. Obtain a timing device to observe the time the stroke counter is on to ensure n is correct. Start the pump and allow oil to circulate until the impulse counter shuts down the instrument.

10.4.16 When all fluid has drained, adjust the volume of oil in the fluid reservoir so that the volume is equal to V_{run} .

10.4.17 Set the impulse counter to $0.5 (n)$.

10.4.18 Close stopcock (6) so that fluid will be stored in the cooling jacket after the pump is started.

10.4.19 Start the pump. When the pump stops and draining is complete, subtract the volume now in the fluid reservoir from V_{run} .

10.4.20 If the difference is within $\pm 2.5 \text{ mL}$ of one half of the total volume ($V_{tot} = V_{run} + V_{res}$), proceed to 10.5.

10.4.21 When the volume in the fluid reservoir is not within $\pm 2.5 \text{ mL}$ of one-half of V_{tot} , drain the fluid from the cooling jacket back into the fluid reservoir, adjust the pump stroke by means of the pump adjustment screw (12), and repeat steps beginning with 10.4.16.

10.5 *Removal of Fluid*—Open the stopcock below the atomization chamber and drain to waste. Drain the fluid from the cooling jacket into a waste container. Position stopcock (8) so that all fluid in the fluid reservoir is removed to a waste container. When drainage is complete, position stopcock (8) so that the drain is closed and the pump inlet line (10) is open.

10.6 *Calibration with RL233:*

10.6.1 Ensure that the ambient (room) temperature is between $20 \text{ }^\circ\text{C}$ and $25 \text{ }^\circ\text{C}$.

10.6.2 Add a minimum of 50 mL of RL233 to the fluid reservoir. Position the three-way stopcock, (6) in Fig. 1, below the cooling vessel to discharge fluid into a suitable waste container and leave the stopcock open below the atomization chamber. Operate the pump until the fluid reservoir is empty but line (10) is still filled with fluid.

10.6.3 Free the apparatus of air in the line by manual compression of the flexible tube that connects the pump to the fluid reservoir. When necessary, venting screw (14) is also used for this purpose.

10.6.4 Add a minimum of 50 mL of test fluid to the fluid reservoir a second time and operate the pump until the fluid reservoir is empty again but line (10) is full.

10.6.5 Close the stopcock below the atomization chamber, position the stopcock below the fluid reservoir so that the line to the pump is open, and retain the position of the stopcock below the cooling jacket so that the first 50 mL of RL233 can be drained into a waste container.

10.6.6 Place a volume of RL233 in the fluid reservoir equal to V_{run} plus 30 mL.

10.6.7 Start the pump, and stop the pump when there is a ~~50 mL~~ 50 mL drop of fluid in the fluid reservoir. After draining is complete, reposition the stopcock below the cooling jacket so subsequent fluid flows directly into the fluid reservoir.

10.6.8 Set the stroke counter for automatic shutoff at the required number of impulses (30 multiplied by n impulses per minute). The flow rate will be 170 mL/min as set in 10.4.

10.6.9 Adjust, if necessary, the volume of fluid in the fluid reservoir to V_{run} .

10.6.10 Place the temperature measuring device in the fluid reservoir, and start the pump.

10.6.11 After about 10 min of operation, adjust the water flow to control the fluid temperature at $30 \text{ }^\circ\text{C}$ to $35 \text{ }^\circ\text{C}$, as measured at the discharge point of the fluid reservoir. Approximately 10 min of operation will be required before the temperature can be stabilized.

10.6.12 At approximately ten cycles of operation, record the gauge pressure reading to the nearest 0.1 MPa (15 psi), when a glycerol-filled pressure gauge is being used, or to 0.01 MPa (1.5 psi), when an electronic pressure device is employed.

10.6.12.1 The pressure measurement device must occasionally be pressure tested to ensure accuracy.

10.6.13 After 30 cycles has elapsed and the pump has stopped, open the stopcock below the atomization chamber and drain fluid into a waste container. Open the three-way stopcock below the fluid reservoir and discharge the first 10 mL to 15 mL as waste in order to flush out the drain line. Discharge the remaining fluid into a clean sample container. After the fluid has drained, close the three-way stopcock.

10.6.14 Remove the thermometer or temperature probe.

10.6.15 Using Test Method [D445](#) or [D7042](#), determine the kinematic viscosity at 100 °C of unsheared (untested) RL233, as well as the sheared fluid from [10.6.13](#). Use the same viscometer tube for the measurement of each oil.

10.6.15.1 If a method other than [D445](#) is used to generate the kinematic viscosity data, apply appropriate relative-bias correction factors as found in the precision section of that method, before performing the calculations of this method.

10.6.16 Calculate viscosity loss (V_L) as follows:

$$V_L = V_u - V_s \quad (2)$$

where:

V_u = kinematic viscosity of unsheared oil at 100 °C, mm²/s, and

V_s = kinematic viscosity of sheared oil at 100 °C, mm²/s.

10.6.17 V_L for RL233 shall be within the range of 2.70 mm²/s to 2.90 mm²/s at 100 °C at a gauge pressure reading between 13.0 MPa and 18.0 MPa, as recorded after 10 min of test time. If this is achieved, the gauge pressure recorded in [10.6.12](#) will subsequently be referred to as the calibration pressure.

10.6.18 If V_L is less than 2.70 mm²/s, increase the gauge pressure. If V_L is greater than 2.90 mm²/s, reduce the gauge pressure, provided that the gauge pressure recorded in [10.6.12](#) is greater than 13.0 MPa and less than 18.0 MPa. To alter the pressure, remove the dust cover of the spray nozzle holder (see [Fig. 4](#)), loosen the locking nut, and turn the adjustment screw that regulates valve opening pressure. Then, tighten the locking nut and replace the dust cover. The nozzle and nozzle holder need not be removed from the apparatus. Upon retesting RL233 the values shall be within the tighter range of 2.75 mm²/s to 2.85 mm²/s at 100 °C at a gauge pressure reading between 13.0 MPa and 18.0 MPa, as recorded after 10 min of test time.

NOTE 15—It is extremely important that the locking nut be completely tightened. When it is not, some leakage of fluid around the outside of the nozzle assembly may occur. This may result in a reduction of mechanical shearing for some oils, which can adversely influence precision. This condition can be monitored by use of a recorder and an electronic pressure measurement device. Leakage results in a sudden drop in pressure when fluid by-passes the nozzle orifice.

10.6.19 When V_L is greater than 2.85 mm²/s at a gauge pressure of only 13.0 MPa, pre-condition the nozzle by substitution of a fully-formulated engine lubricant as the test fluid. The stroke counter shut-off shall be adjusted so that the test time is at least 8 h, instead of 30 min. Upon retesting RL233 the values shall be within the tighter range of 2.75 mm²/s to 2.85 mm²/s at 100 °C at a gauge pressure reading between 13.0 MPa and 18.0 MPa, as recorded after 10 min of test time.

NOTE 16—Suitable break-in oils include, but are not limited to, fully-formulated SAE 15W-40 heavy-duty engine lubricants.

10.6.20 When viscosity decrease is below 2.75 mm²/s at a gauge pressure of 18.0 MPa, another nozzle shall be installed and the calibration procedure shall be repeated.

NOTE 17—Before calibration with a new nozzle, it is advisable to subject the nozzle to at least a 4 h run-in with break-in oil.

10.7 Calibration Period:

10.7.1 *Calibration with RL233 Fluid*—Frequent testing of the apparatus with the calibration oil is recommended. The apparatus shall be recalibrated after 540 cycles.

10.7.2 *Calibration with RL233 and Monitoring System Stability and Precision with a Quality Control Oil per Practice [D6299](#)*—A quality control oil can be used to monitor calibration once the nozzle has been calibrated with RL233 fluid. This quality

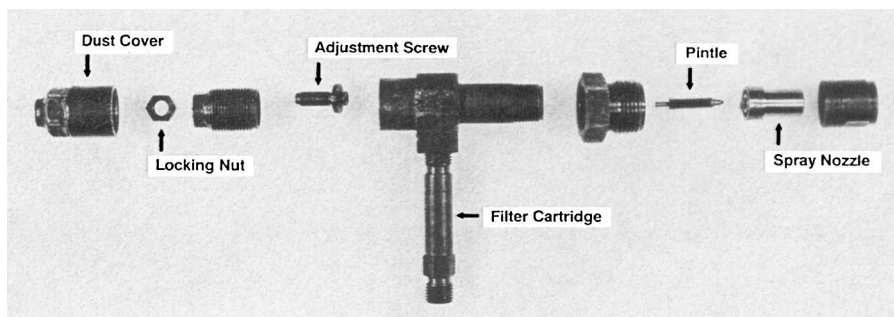

FIG. 4 Spray Nozzle and Nozzle Holder