



Designation: **D7171–16 D7171 – 20**

Standard Test Method for Hydrogen Content of Middle Distillate Petroleum Products by Low-Resolution Pulsed Nuclear Magnetic Resonance Spectroscopy¹

This standard is issued under the fixed designation D7171; the number immediately following the designation indicates the year of original adoption or, in the case of revision, the year of last revision. A number in parentheses indicates the year of last reappraisal. A superscript epsilon (ϵ) indicates an editorial change since the last revision or reappraisal.

1. Scope*

1.1 This test method covers the determination of the hydrogen content of middle distillate petroleum products using a low-resolution pulsed nuclear magnetic resonance (NMR) spectrometer. The boiling range of distillates covered by the test method is 150 °C to 390 °C. While this test method may be applicable to middle distillates outside this boiling range, in such cases the precision statements may not apply. The test method is generally based on Test Methods **D3701** and **D4808**, with a major difference being the use of a pulsed NMR spectrometer instead of a continuous wave NMR spectrometer.

1.2 The values stated in SI units are to be regarded as standard. No other units of measurement are included in this standard.

1.2.1 The preferred units are mass %.

1.3 *This standard does not purport to address all of the safety concerns, if any, associated with its use. It is the responsibility of the user of this standard to establish appropriate safety, health, and environmental practices and determine the applicability of regulatory limitations prior to use.*

1.4 *This international standard was developed in accordance with internationally recognized principles on standardization established in the Decision on Principles for the Development of International Standards, Guides and Recommendations issued by the World Trade Organization Technical Barriers to Trade (TBT) Committee.*

2. Referenced Documents

2.1 *ASTM Standards:*²

D3701 Test Method for Hydrogen Content of Aviation Turbine Fuels by Low Resolution Nuclear Magnetic Resonance Spectrometry

D4057 Practice for Manual Sampling of Petroleum and Petroleum Products

D4808 Test Methods for Hydrogen Content of Light Distillates, Middle Distillates, Gas Oils, and Residua by Low-Resolution Nuclear Magnetic Resonance Spectroscopy

D5291 Test Methods for Instrumental Determination of Carbon, Hydrogen, and Nitrogen in Petroleum Products and Lubricants

D6299 Practice for Applying Statistical Quality Assurance and Control Charting Techniques to Evaluate Analytical Measurement System Performance

D6708 Practice for Statistical Assessment and Improvement of Expected Agreement Between Two Test Methods that Purport to Measure the Same Property of a Material

2.2 *Other Documents:*

MIL-DTL-5624 Turbine Fuel, Aviation, Grades JP-4 and JP-5³

MIL-DTL-83133 Turbine Fuel, Aviation, Kerosene Type, JP-8 (NATO F-34), NATO F-35, and JP-8+100 (NATO F-37)

MIL-DTL-16884 Fuel, Naval Distillate

3. Terminology

3.1 *Definitions:*

¹ This test method is under the jurisdiction of ASTM Committee **D02** on Petroleum Products, Liquid Fuels, and Lubricants and is the direct responsibility of Subcommittee **D02.03** on Elemental Analysis.

Current edition approved ~~Oct. 1, 2016~~ May 1, 2020. Published ~~October 2016~~ June 2020. Originally approved in 2005. Last previous edition approved in 2016 as D7171 – 05 (2016) – 16. DOI: [10.1520/D7171-16.10.1520/D7171-20](https://doi.org/10.1520/D7171-16.10.1520/D7171-20).

² For referenced ASTM standards, visit the ASTM website, www.astm.org, or contact ASTM Customer Service at service@astm.org. For *Annual Book of ASTM Standards* volume information, refer to the standard's Document Summary page on the ASTM website.

³ Available online at the ASSIST Quick Search website <http://quicksearch.dla.mil>.

*A Summary of Changes section appears at the end of this standard

3.1.1 *calibration, n*—the determination of the values of the significant parameters by comparison with values indicated by a set of calibration standards.

3.1.2 *calibration curve (or calibration line), n*—the graphical or mathematical representation of a relationship between the assigned (known) values of calibration standards and the measured responses from the measurement system.

3.1.3 *calibration standard, n*—a standard having an assigned (known) value (reference value) for use in calibrating a measurement instrument or system. This standard is not used to determine the accuracy of the measurement instrument or system (see *check standard*).

3.1.4 *check standard, n*—~~a in QC testing, material having an assigned (known) value (reference value) accepted reference value used to determine the accuracy of the measurement instrument or system. This standard is not used to calibrate the measurement instrument or system (see system calibration standard).~~

3.1.4.1 *Discussion*—

This standard is not used to calibrate the measurement instrument or system (see *calibration standard*).

3.1.5 *low resolution nuclear magnetic resonance (NMR) spectroscopy, n*—a form of NMR spectroscopy using a simple NMR analyzer that employs a low magnetic field and consequentially low NMR frequency. An example is proton NMR below 60 MHz. Resolution is expressed as time at half height of signal and is typically 1 millisecond (ms) or less.

3.1.6 *nuclear magnetic resonance (NMR) spectroscopy, n*—that form of spectroscopy concerned with radio-frequency-induced transitions between magnetic energy levels of atomic nuclei.

3.1.7 *radio frequency, n*—the range of frequencies of electromagnetic radiation between 3 kHz and 300 GHz.

3.1.8 *recycle delay, n*—NMR spectrometer parameter setting for the time delay that allows magnetization recovery.

3.1.9 *relaxation time constant (T_1), n*—a numerical value which is a measure of magnetization relaxation time following an excitation pulse of an NMR spectrometer.

4. Summary of Test Method

4.1 A test specimen is analyzed in a pulsed NMR spectrometer calibrated with reference standard materials. The analyzer records in a nondestructive fashion the total NMR signal, which arises from the absolute amount of hydrogen atoms in the reference standards and test sample. The absolute hydrogen signal intensity reported by the pulsed NMR instrument for the standard and test specimens is normalized by the corresponding sample mass. The resulting signal-per-gram ratios are used as a means of comparing theoretical hydrogen contents of the standards with that of the sample. The result is expressed as the hydrogen content (on a mass % basis) of the sample.

4.2 To ensure an accurate measure of the absolute hydrogen content of the reference standards and sample, it is necessary to ensure that the measured hydrogen signal intensity is always directly proportional to the absolute hydrogen content of the standards and sample.

4.3 Undercounting of the reference standard with respect to the sample is avoided by a number of strategies, including accurate filling into the linear response region of the sample compartment so that the mass recorded for the sample represents the true amount measured by NMR, and use of a recycle delay considerably greater than the longest relaxation time constant (T_1) for the sample.

5. Significance and Use

5.1 Hydrogen content represents a fundamental quality of a petroleum distillate that has been correlated with many of the performance characteristics of that product. Combustion properties of gas turbine fuels are related primarily to hydrogen content. As hydrogen content of these fuels decreases, soot deposits, exhaust smoke, and thermal radiation increase. Soot deposits and thermal radiation can increase to the point that combustor liner burnout will occur. Hydrogen content is a procurement requirement of the following military fuels: JP-5 specified in MIL-DTL-5624, JP-8 specified in MIL-DTL-83133, and Naval Distillate Fuel specified in MIL-DTL-16884.

5.2 This test method provides a simple and precise alternative to existing test methods (D3701, D4808, and D5291) for determining the hydrogen content of petroleum distillate products.

6. Apparatus

6.1 *Nuclear Magnetic Resonance Spectrometer:*

6.1.1 This test method requires a low-resolution pulsed instrument capable of measuring a nuclear magnetic resonance signal due to hydrogen atoms in the sample in a linear fashion over the filling volume of interest. The instrument includes the following:

6.1.1.1 Permanent magnet to provide the necessary static magnetic field for the NMR test,

6.1.1.2 Sample compartment containing a radio frequency (RF) coil for excitation and detection, and

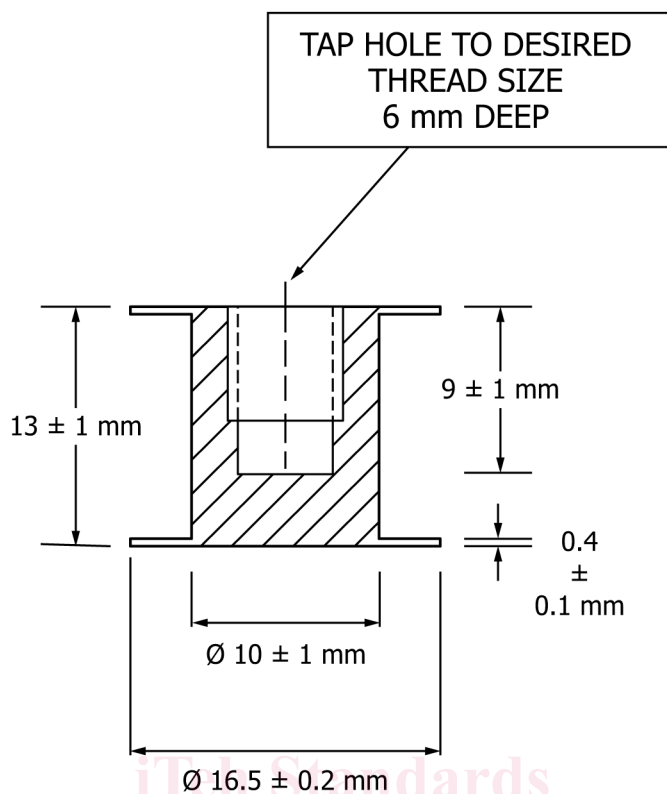

FIG. 1 Example of a PTFE Plug (not to scale)

standards
<https://standards.iteh.ai>
 Document Preview

6.1.1.3 Electronic unit to control and monitor the resonance condition involving magnet temperature control and field offset coils.

6.1.2 The test method also requires that the instrument have the ability to equilibrate samples within the probe at a constant temperature (that is, 35 °C or 40 °C).

6.2 *Conditioning Block*—Block of aluminum alloy drilled with holes of sufficient size to accommodate the nominal 18 mm diameter test cells to a depth of at least 42 mm and with a centrally positioned well to house a temperature-sensing device, such as a thermometer or thermocouple.

6.3 *Conditioning Apparatus*—Bath or other temperature control device (into which the conditioning block is inserted) for controlling block temperature to 35 °C ± 0.2 °C or 40 °C ± 0.2 °C.

6.4 *Test Cell*—Glass tube (with a flat or round bottom) with an outside diameter of 17.6 mm to 18.1 mm and an inside diameter of 15.2 mm to 16.4 mm. Any tube length that permits easy insertion into and removal from the NMR sample chamber may be used.

6.5 *Polytetrafluorethylene (PTFE) Plug*—Device made of PTFE used to tightly fit and close the test cells. An example of one type of PTFE plug design is shown in Fig. 1.

6.6 *Insertion Rod*—Straight, rigid rod with a threaded end (to screw into the PTFE plug) for inserting and removing the PTFE plugs from the test cells. Any diameter and length rod that facilitates easy plug insertion and removal may be used.

6.7 *Analytical Balance*—Top loading pan-type balance, capable of weighing the test cells in an upright position to an accuracy of 0.001 g or better.

6.8 *Volume Transferring Device*—Capable of accurately and repeatedly delivering a fixed volume of material within ±1 % or better, for use in preparing test specimens and standards for analysis. A 10 mL capacity serological pipet with 0.1 mL marked subdivisions has been found suitable to use.

TABLE 1 Hydrogen Content of Reference Standards

Compound	Mass % Hydrogen
dodecane	15.386
pentadecane	15.185
2-nonanone	12.756
ethyl caprate	12.077
octyl acetate	11.703
ethyl heptanoate	11.466
3-cyclohexanepropionic acid	10.324
cyclohexyl acetate	9.924
diethyl malonate	7.552
2-phenylethyl acetate	7.367

7. Reagents and Materials

7.1 *Purity of Reagents*—Reagent grade chemicals shall be used in all tests. Unless otherwise indicated, it is intended that all reagents conform to the specifications of the Committee on Analytical Reagents of the American Chemical Society where such specifications are available.⁴ Other grades may be used, provided it is first ascertained that the reagent is of sufficiently high purity to permit its use without lessening the accuracy of the determination.

7.2 *List of Available Calibration, Reference, or Check Standards* (see Table 1). (**Warning**—Irritant. Combustible. Avoid breathing vapor. Avoid contact with eyes, skin, and clothing.) applies to all of the following:

7.2.1 *3-cyclohexanepropionic acid*, 99 % minimum purity.

7.2.2 *cyclohexyl acetate*, 99 % minimum purity.

7.2.3 *diethyl malonate*, 99 % minimum purity.

7.2.4 *dodecane*, 99 % minimum purity.

7.2.5 *ethyl caprate*, 99 % minimum purity.

7.2.6 *ethyl heptanoate*, 99 % minimum purity.

7.2.7 *2-nonanone*, 99 % minimum purity.

7.2.8 *octyl acetate*, 99 % minimum purity.

7.2.9 *pentadecane*, 99 % minimum purity.

7.2.10 *2-phenylethyl acetate*, 99 % minimum purity.

7.3 *Quality Control (QC) Samples*, preferably are portions of one or more petroleum distillate materials that are stable and representative of the samples of interest. These QC samples can be used to monitor the precision and stability of the testing process as described in Section 15.

8. Hazards

8.1 Wear appropriate personal protective equipment when working with the materials in Section 7. Transfer all reagents in a fume hood and immediately seal containers tightly. Avoid prolonged or repeated exposure to materials.

9. Sampling

9.1 Take a homogeneous sample in accordance with Practice D4057. Mix the sample prior to taking a representative aliquot as the test specimen.

10. Preparation of Test Specimens and Standards

10.1 Fig. 1 is an example of a PTFE plug. Dimensions may be varied to best seal the chosen test cell. Drill and thread the plug hole to mate the insertion rod thread. All test cells and PTFE plugs used shall be well cleaned and dry. Weigh a clean empty test cell and PTFE plug (W_1) on an analytical balance to the nearest 0.001 g. Use of a jig for supporting the test cell on the balance pan is recommended for flat bottom test cells and required for round bottom test cells. For round bottom test cells, a paper clip dispenser (with hole in top) works well for this function. Transfer a fixed volume (in accordance with the tolerances specified in 6.8) of a reference standard or test specimen into the test cell to a fill height of nominally 32 mm (representing a nominal 6 mL volume). The choice of fill height is not critical, but fill height shall be the same for all standards and samples to ensure good results. Use the same test cell source (that is, manufacturer and part number) for all standards and test specimens. This will ensure uniformity of fluid height in the NMR sample compartment, an important parameter in the test method. Take care to not introduce the fluid down the side of the test cell. Seal the reference standard container immediately after the material transfer to minimize moisture pickup. Using the insertion rod with a PTFE plug attached, push the PTFE plug into the test cell until it is just above

⁴ *Reagent Chemicals, American Chemical Society Specifications, ACS Reagent Chemicals, Specifications and Procedures for Reagents and Standard-Grade Reference Materials*, American Chemical Society, Washington, DC. For ~~Suggestions~~ suggestions on the testing of reagents not listed by the American Chemical Society, see *Annual Analytical Standards for Laboratory Chemicals*, BDH Ltd., Poole, Dorset, U.K., and the *United States Pharmacopeia and National Formulary*, U.S. Pharmacopeial Convention, Inc. (USPC), Rockville, MD.