



Designation: D4724/D4724M – 20

Standard Test Method for Entanglements in Filament Yarns by Needle Insertion¹

This standard is issued under the fixed designation D4724/D4724M; the number immediately following the designation indicates the year of original adoption or, in the case of revision, the year of last revision. A number in parentheses indicates the year of last reapproval. A superscript epsilon (ϵ) indicates an editorial change since the last revision or reapproval.

1. Scope

1.1 This test method covers two options for the measurement of entanglements in filament yarns using needle insertion options for instrument (Option 1) (Option 2) techniques.

1.2 The values stated in either SI units or inch-pound units are to be regarded separately as standard. The values stated in each system are not necessarily exact equivalents; therefore, to ensure conformance with the standard, each system shall be used independently of the other, and values from the two systems shall not be combined.

1.3 *This standard does not purport to address all of the safety concerns, if any, associated with its use. It is the responsibility of the user of this standard to establish appropriate safety, health, and environmental practices and determine the applicability of regulatory limitations prior to use.*

1.4 *This international standard was developed in accordance with internationally recognized principles on standardization established in the Decision on Principles for the Development of International Standards, Guides and Recommendations issued by the World Trade Organization Technical Barriers to Trade (TBT) Committee.*

2. Referenced Documents

2.1 *ASTM Standards:*²

[D123 Terminology Relating to Textiles](#)

[D1776 Practice for Conditioning and Testing Textiles](#)

[D2258 Practice for Sampling Yarn for Testing](#)

[D4849 Terminology Related to Yarns and Fibers](#)

3. Terminology

3.1 *Definitions:*

3.1.1 For definitions of terms relating to yarns and fibers, refer to Terminology [D4849](#).

3.1.1.1 The following terms are relevant to this standard: entanglement, filament yarn.

3.2 For definitions of other textile terms used in this test method, refer to Terminology [D123](#).

4. Summary of Test Method

4.1 A summary of each option is in the section for that option.

5. Significance and Use

5.1 Option 1 of this test method is for the determination of the degree of filament yarn entanglement, as measured instrumentally. It is used for acceptance testing of commercial shipments; however, caution is advised because information on between-laboratory precision is lacking. Comparative tests, as directed in [5.1.1](#), may be advisable.

5.1.1 If there are differences of practical significance between the reported test results for two or more laboratories, comparative tests should be performed by those laboratories to determine if there is a statistical bias between them, using competent statistical assistance. As a minimum, samples used for each comparative test should be as homogeneous as possible, drawn from the same lot of material as the samples that results in disparate results during initial testing, and randomly assigned in equal numbers to each laboratory. Other fabrics with established test values may be used for this purpose. The test results from the laboratories involved should be compared statistically. If a bias is found, either its cause must be found and corrected or future test results must be adjusted in consideration of the known bias.

5.2 Option 2 for this test method is intended for use when the supply of yarn is limited.

5.3 The instrumental option of this test method, Option 1, is based on the total randomization of the entanglements in the yarn; therefore, the distance measured between the point of insertion of a pin in the middle of the yarn and the point at which an entanglement is encountered, by movement of the yarn or the pin until it is stopped at a preset level of force, is representative of the distance between two entanglements at some location in the yarn.

5.4 Entanglements are used frequently instead of twist to ensure the integrity of filament yarns. Such entanglements

¹ This test method is under the jurisdiction of ASTM Committee [D13](#) on Textiles and is the direct responsibility of Subcommittee [D13.58](#) on Yarns and Fibers.

Current edition approved April 1, 2020. Published June 2020. Originally approved in 1999. Last previous edition approved in 2011 as D4724-11. DOI: 10.1520/D4724_D4724M-20.

² For referenced ASTM standards, visit the ASTM website, www.astm.org, or contact ASTM Customer Service at service@astm.org. For *Annual Book of ASTM Standards* volume information, refer to the standard's Document Summary page on the ASTM website.

generally give somewhat less protection during weaving or knitting than twist, but with proper care, will perform quite satisfactorily.

6. Sampling and Test Specimens

6.1 *Primary Sampling Unit*—Consider shipping containers or production lots of yarn to be the primary sampling unit.

NOTE 1—A realistic specification or other agreement between the purchaser and the supplier requires taking into account the variability between lots, shipping containers, packages within a shipping container, and successive lengths from a package to provide a plan that, at the specified level for the property of interest, has a meaningful producer’s risk, consumer’s risk, acceptable quality level, and limiting quality level.

6.2 *Laboratory Sample Unit*—For each primary sampling unit, take laboratory sampling units as directed in Practice **D2258**. Do not rewind or transfer material from packages taken from shipping containers to other packages.

6.3 *Test Specimen*—For acceptance testing, use laboratory sample units as a source of specimens. Make (20–100) observations on each laboratory sampling unit.

7. Conditioning

7.1 *Preparation of Test Package*—Before preconditioning or conditioning the test package, remove at least 100 m or 110 yds of yarn from the test package to avoid testing nonrepresentative yarn.

7.2 *Preconditioning*—Normally, preconditioning is not necessary unless the test packages are received with higher than the normal moisture level. If preconditioning is necessary, treat the packages as directed in Practice **D1776**.

7.3 *Conditioning*—Condition the test packages as directed in Practice **D1776**.

OPTION 1—INSTRUMENTAL MEASUREMENT OF THE DEGREE OF ENTANGLEMENT OF FILAMENT YARN

8. Summary of Option

8.1 A yarn is passed at constant speed and constant pretension through the thread path of the instrument. After a required yarn length has run through, the yarn is pierced by a needle, and advanced automatically until a preset needle tension is attained. Then, the needle is withdrawn, and the yarn length from insertion to this critical point is measured automatically. This cycle of yarn advance, piercing by the needle, and length measurement is repeated for a predetermined number of times. The individually measured pulled yarn lengths and the total of these yarn lengths are automatically recorded.

8.2 Apparatus

8.2.1 *Automatic Needle Pull Entanglement Testers*, Lenzing Instruments rapid automatic pin insertion detector (RAPID)³ with rotating pin, rapid automatic pin insertion detector (RAPID-V)³ with vertical pin and Rothschild automatic yarn entanglement testers NPT.³

8.2.2 *Standard Laboratory Weights*, ranging from 1 to 100 g.

8.2.3 *Stopwatch*, with 1/5-s divisions.

8.2.4 *Speed Indicator*, tachometer, 0 to 1000 rpm range.

8.2.5 *Magnetic Whorl Tensioning Device*, optional.

8.3 Procedure

8.3.1 Test the yarn in the standard atmosphere for testing textiles, as directed in Practice **D1776**.

8.3.2 Calibrate the entanglement tester and tensiometer as prescribed by the instrument manufacturer.

8.3.3 Mount the test package on a suitable holder.

8.3.4 *Yarn Pretension*—Calculate the pretension by using one of the equations below:

$$YP [g] = 0.75 * \sqrt{D} \text{ for denier} \quad (1)$$

$$YP [cN] = 0.7 * \sqrt{T} \text{ for dtex} \quad (2)$$

$$YP [cN] = 2.21 * \sqrt{T} \text{ for tex} \quad (3)$$

8.3.5 *Trip Level Tension*—Calculate the trip level by using one of the equations below:

8.3.5.1 For linear density ≥ 40 dtex, 4 tex or 36 den:

$$TLT [g] = 3.50 * D^{0.35} \text{ for denier} \quad (4)$$

$$TLT [cN] = 3.31 * T^{0.35} \text{ for dtex} \quad (5)$$

$$TLT [cN] = 7.41 * T^{0.35} \text{ for tex} \quad (6)$$

8.3.5.2 For linear density < 40 dtex, 4 tex or 36 den:

$$TLT [g] = 0.36 * D - 0.68 \text{ for denier} \quad (7)$$

$$TLT [cN] = 0.318 * T - 0.68 \text{ for dtex} \quad (8)$$

$$TLT [cN] = 0.0318 * T - 0.68 \text{ for tex} \quad (9)$$

where:

YP = yarn pretension, cN [gf]

TLT = trip level tension, cN [gf],

T = linear density, tex or dtex, and

D = linear density, denier.

8.3.6 Set the RAPID instrument as follows:

8.3.6.1 *Continuous Yarn Speed During Measurement*—0.5–20 m/min.

8.3.6.2 *Observations/Package*—20–100.

8.3.6.3 *No-show Length*—Refer to the manufacturer’s manual.

8.3.6.4 Present the loose end of the yarn to the inlet gun (see **Fig. 1** and **Fig. 2**). The instrument will string up, automatically strip some yarn, start the measurement cycle, and discard the tested yarn to waste.

If there is no entanglement in the “No-Show” length, the instrument will do the following:

(1) If the “Pin Miss Ignored Limit” has not been exceeded, rotate the pinwheel, reinsert the needle in the yarn, and continue testing. The test is aborted and a “No-Show” recorded.

(2) If the “Pin Miss Ignored Limit” has been exceeded, enter a “Freeze” state and request confirmation of pin insertion. The operator will restart the test if the pin did not pierce the yarn (increasing the “Pin Miss Count” by 1, or the operator will

³ Apparatus is commercially available.

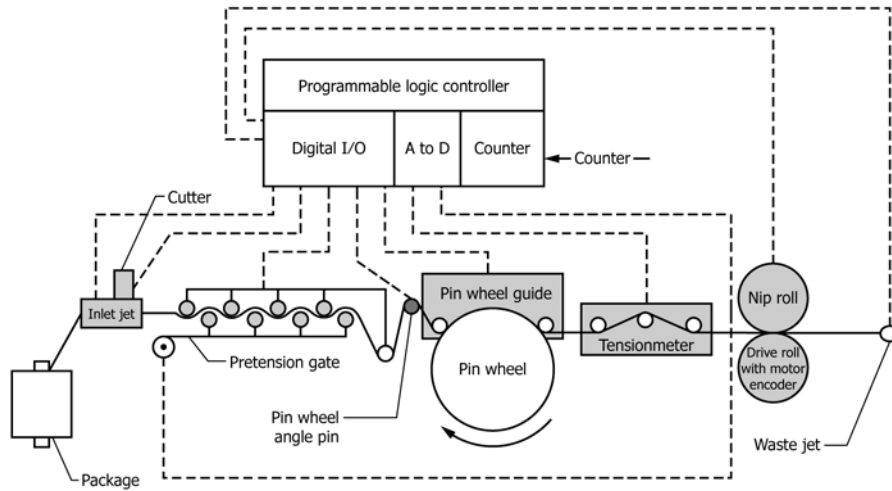

FIG. 1 Yarn String-Up Diagram for Rapid Automatic Pin Insertion Detector (RAPID) with Rotating Pin

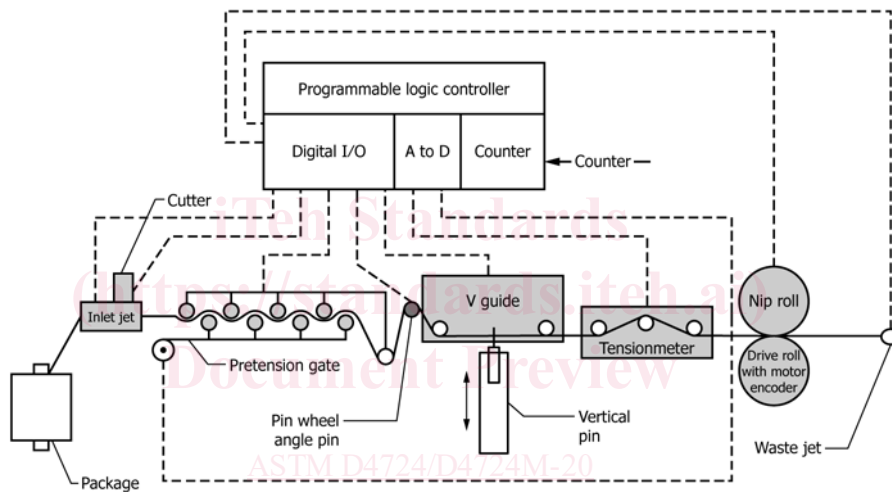

FIG. 2 Yarn String-Up Diagram for Rapid Automatic Pin Insertion Detector (RAPID – V) with Vertical Pin

acknowledge pin piercing by pressing the “Confirm” button designating this a true no entanglement section, which adds the length to the results.

NOTE 2—For Rapid with rotating pin wheel: the device can have a significant “skip distance,” being a yarn length skipped by the pinwheel (combination of rotation time and measuring speed). No entanglements can be recorded over this length. Care has to be taken that distances between entanglements in the test material are exceeding this “skip distance.”

NOTE 3—For Rapid-V with vertical pin: the device has a configurable “skip distance,” defines the yarn length from withdraw and reinsert into the yarn. The recorded “skip distance” length is automatically added to pulled yarn length for the following entanglement.

8.3.7 Set the Rothschild instrument as follows:

8.3.7.1 *Yarn Speed Between Entanglements*—1–20 m/min.

8.3.7.2 *Inter-trip Speed (yarn speed in-between two entanglements when needle is out)*—0.1–5 m/min.

8.3.7.3 *Forwarding Time*—5 s.

8.3.7.4 *Observations/Package (decade counter)*—20–100.

8.3.7.5 *No-Show Length*—500 mm or as specified by user. This is an optional setting and the length should be established based on the product or end-use of the product.

8.3.7.6 Feed the yarn from the package through the pretension device. The yarn then is threaded across the needle piercing section and through the measuring head. Then, yarn goes to a yarn speed roll and is taken up to the “Take-up” wheel (see Fig. 3) or can bypass the “Take-up” wheel and go into the aspirator after the yarn speed roll, to prevent buildup on the take-up wheel. The software initializes a specified length for stripping and starts the test.

If there is no entanglement in the “No-Show” length, the instrument will do the following:

- (1) Stop the yarn and withdraw the needle.
- (2) Record a “No-Show” in the software (and on the printout).
- (3) Reinsert the needle into the yarn and wind until a node (entanglement) is detected.
- (4) The first entanglement after a “No-Show” is ignored.
- (5) The needle is withdrawn, and the yarn is advanced to the specified length and is reinserted into the yarn and the test continues. This is to ensure that an accurate reference between entanglement is established.