



Designation: D4058 – 96 (Reapproved 2020)

Standard Test Method for Attrition and Abrasion of Catalysts and Catalyst Carriers¹

This standard is issued under the fixed designation D4058; the number immediately following the designation indicates the year of original adoption or, in the case of revision, the year of last revision. A number in parentheses indicates the year of last reapproval. A superscript epsilon (ϵ) indicates an editorial change since the last revision or reapproval.

1. Scope

1.1 This test method covers the determination of the attrition and abrasion resistance of catalysts and catalyst carriers. It is applicable to tablets, extrudate, spheres, and irregularly shaped particles larger than about $\frac{1}{16}$ in. (1.6 mm) and smaller than about $\frac{3}{4}$ in. (19 mm). The materials used in developing the method exhibited losses on attrition less than 7%; however, the method should be applicable to materials giving much higher attritions.

1.2 The values stated in inch-pound units are to be regarded as standard. The values given in parentheses are mathematical conversions to SI units that are provided for information only and are not considered standard.

1.3 *This standard does not purport to address all of the safety concerns, if any, associated with its use. It is the responsibility of the user of this standard to establish appropriate safety, health, and environmental practices and determine the applicability of regulatory limitations prior to use.*

1.4 *This international standard was developed in accordance with internationally recognized principles on standardization established in the Decision on Principles for the Development of International Standards, Guides and Recommendations issued by the World Trade Organization Technical Barriers to Trade (TBT) Committee.*

2. Referenced Documents

2.1 *ASTM Standards:*²

[E177 Practice for Use of the Terms Precision and Bias in ASTM Test Methods](#)

[E456 Terminology Relating to Quality and Statistics](#)

[E691 Practice for Conducting an Interlaboratory Study to Determine the Precision of a Test Method](#)

¹ This test method is under the jurisdiction of ASTM Committee D32 on Catalysts and is the direct responsibility of Subcommittee D32.02 on Physical-Mechanical Properties.

Current edition approved May 15, 2020. Published June 2020. Originally approved in 1981. Last previous edition approved in 2015 as D4058 – 96(2015). DOI: 10.1520/D4058-96R20.

² For referenced ASTM standards, visit the ASTM website, www.astm.org, or contact ASTM Customer Service at service@astm.org. For *Annual Book of ASTM Standards* volume information, refer to the standard's Document Summary page on the ASTM website.

3. Summary of Test Method

3.1 A sample of catalyst or catalyst carrier is rotated for a fixed number of revolutions in a cylindrical drum having a single baffle. Fines produced by attrition and abrasion in the test are determined by sieving through a standard sieve.

4. Significance and Use

4.1 This test method is considered to be a measure of the propensity of a catalyst to produce fines in the course of transportation, handling, and use. However, there is no absolute level of acceptability. The values obtained are significant principally in relation to values for other materials (or other samples of the same material) of comparable size.

5. Apparatus

5.1 A cylindrical drum with inside dimensions of 10 in. (254 mm) diameter and 6 in. (152 mm) long with a single radial baffle 2 in. (51 mm) high extending the full length of the cylinder. A lid shall be provided and secured to the container with Allen-head screws, wing nuts or other suitable means as to ensure that no fines escape during the test. The inside of the drum should have a surface roughness no greater than about 250 μ m. (6.4 μ m). (The roughness of cold-rolled steel or a smooth grind on a lathe is satisfactory.) A suitable design is shown in Fig. 1.

5.2 Any convenient means of rotation, such as a ball mill roller, geared to give the desired rate of rotation of the drum.

6. Sampling

6.1 Obtain a representative sample of about 110 g of the material to be tested by gently splitting or quartering. Any sampling technique requiring extensive agitation or handling will cause some attrition and, therefore, compromise the results of the test.

6.2 Gently sieve the sample on a No. 20 (850- μ m) ASTM sieve.

6.3 Transfer the presieved sample to a widemouthed container tared to the nearest 0.01 g.

6.4 Dry the presieved sample in air for 3 h at 400 °C. It may be necessary to modify or eliminate this step when testing materials that might be decomposed or drastically altered by the drying conditions.

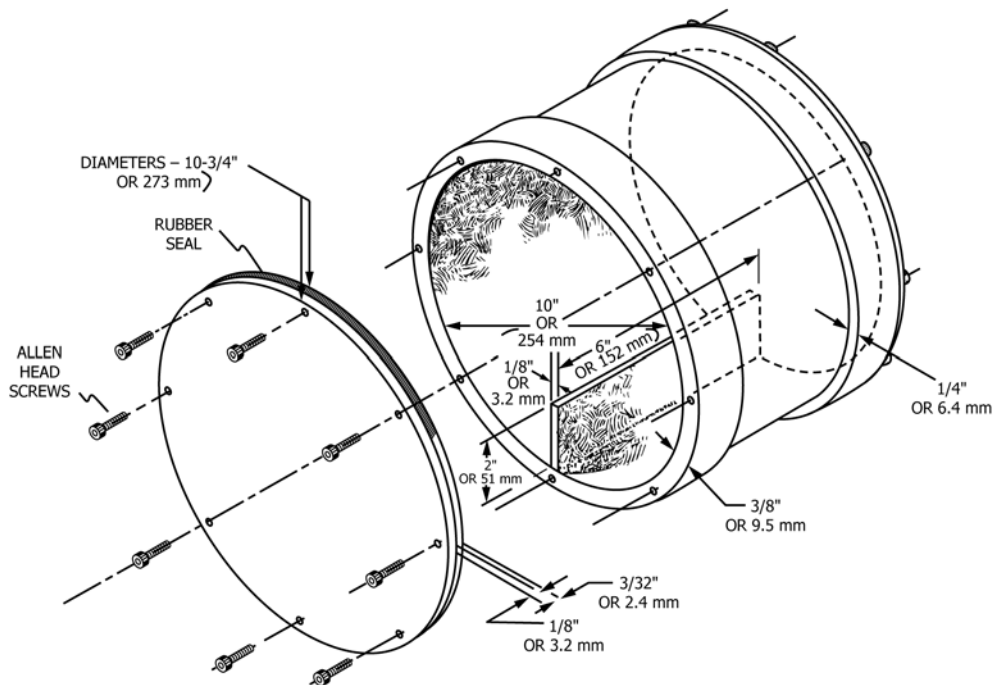

FIG. 1 Drum for Determining Attrition and Abrasion (Stainless Steel Fabrication)

NOTE 1—For example, an activated carbon catalyst may be treated for 4 h at 190 °C in a vacuum oven.

6.5 Cool the dried sample for at least 30 min in a desiccator using freshly regenerated 4A molecular sieves as the desiccant. The molecular sieves shall be regenerated at 220 to 260 °C.

NOTE 2—Multiple samples can be handled simultaneously in 6.4 and 6.5. However, they should remain in a desiccator before analyzing.

7. Procedure

7.1 Clean the test cylinder and lid of the apparatus using a fine-bristle brush.

7.2 Weigh about 100 g of the pretreated sample from 6.5 to the nearest 0.01 g. Record this weight as *A*.

7.3 Transfer the weighed sample into the test cylinder.

7.4 Carefully seal the cover and position the test cylinder for rotation.

7.5 Rotate the test cylinder 1800 revolutions at a rate of 60 ± 5 rpm.

7.6 After the rotation prescribed in 7.5, rotate the test cylinder until the baffle is at the top and tap the test cylinder with a rubber mallet several times to allow the fines to settle to the bottom of the test cylinder.

7.7 Place a No. 20 (850-µm) ASTM sieve with pan under the test cylinder and carefully remove the cover.

7.8 Pour the test sample onto the sieve. Use a fine-bristle brush to clean out the test cylinder and its cover.

7.9 Sieve the fines into the pan by gently shaking the sieve by hand; avoid excessive agitation (refer to 6.1).

7.10 Dry the fraction on the sieve at the same conditions used for the original sample (refer to 6.4).

7.11 Weigh the dried fraction to the nearest 0.01 g. Record this weight as *B*.

8. Calculation

8.1 Calculate the percent loss on attrition as follows:

$$\text{Loss on attrition, \%} = \frac{A - B}{A} \times 100 \quad (1)$$

Example: *A* = 100.00 g test sample
B = 98.60 g on sieve

$$\frac{(100.00 - 98.60)}{100.00} \times 100 = 1.4\% \quad (2)$$

When the loss on attrition is less than 1.0 %, report it as “less than 1 %.”

9. Precision and Bias³

9.1 *Test Program*—An interlaboratory study was conducted in which the named property was measured in two separate test materials in nine separate laboratories. Practice E691, modified for non-uniform data sets, was followed for the data reduction. Analysis details are in the research report.

9.2 *Precision*—Pairs of test results obtained by a procedure similar to that described in the study are expected to differ in absolute value by less than 2.772*S*, where 2.772*S* is the 95 % probability interval limit on the difference between two test results, and *S* is the appropriate estimate of standard deviation. Definitions and usage are given in Terminology E456 and Practice E177, respectively.

³ Supporting data have been filed at ASTM International Headquarters and may be obtained by requesting Research Report RR:D32-1003.