



Designation: **F1956 – 13 F1956 – 20**

Standard Specification for Rescue Carabiners¹

This standard is issued under the fixed designation F1956; the number immediately following the designation indicates the year of original adoption or, in the case of revision, the year of last revision. A number in parentheses indicates the year of last reappraisal. A superscript epsilon (ϵ) indicates an editorial change since the last revision or reappraisal.

1. Scope

1.1 This specification covers six mechanical tests, one corrosion resistance test, and the minimum performance requirements for these tests. This specification applies to carabiners designed specifically for use by rescue personnel during both training exercises and actual rescue operations. This specification does not apply to recreational use carabiners.

1.2 Two different types of carabiners are defined in this specification, a heavy-duty rescue carabiner and a ~~light-duty~~ standard-duty rescue carabiner.

~~1.3 The values stated in SI units are to be regarded as the standard.~~

1.3 Tests contained herein are destructive in nature. Carabiners subjected to any of these tests shall not be used in any way after testing except in evaluation the results of such testing.

1.4 This specification does not imply approval of any method of use of rescue carabiners. In addition, the tests described are laboratory tests and do not duplicate field conditions. Furthermore, the test load values contained herein are not to be interpreted as the forces which a rescue carabiner may be subjected to, or may be expected to sustain, in actual field use.

1.5 Quality control is solely the responsibility of the manufacturer or purchaser, or both, and is not addressed by this specification.

1.6 The values stated in SI units are to be regarded as the standard.

1.7 This standard may involve hazardous materials, operations, and equipment. *This standard does not purport to address all of the safety concerns, if any, associated with its use. It is the responsibility of the user of this standard to establish appropriate safety, health, and ~~health~~ environmental practices and determine the applicability of regulatory limitations prior to use.*

1.8 This international standard was developed in accordance with internationally recognized principles on standardization established in the Decision on Principles for the Development of International Standards, Guides and Recommendations issued by the World Trade Organization Technical Barriers to Trade (TBT) Committee.

<https://standards.iteh.ai/catalog/standards/sist/1cb421a0-525d-41ea-9538-bd8b2d682c7/astm-f1956-20>

2. Referenced Documents

2.1 *ASTM Standards:*²

B117 Practice for Operating Salt Spray (Fog) Apparatus

E4 Practices for Force Verification of Testing Machines

3. Terminology

3.1 *Definitions:*

3.1.1 *carabiner*—a load-bearing, connective device with a self-closing gate.

3.1.2 ~~heavy-duty rescue carabiner~~—*durably affixed*—a carabiner that meets the specifications for a heavy-duty rescue carabiner as defined in Section ~~manner of attaching information directly to the product which endures for the life of the product~~ **9**.

3.1.3 ~~light-duty~~ heavy-duty rescue carabiner—*a carabiner that meets the specifications for a ~~light-duty~~ heavy-duty rescue carabiner as defined in Section **9**.*

¹ This specification is under the jurisdiction of ASTM Committee **F32** on Search and Rescue and is the direct responsibility of Subcommittee **F32.01** on Equipment, Testing, and Maintenance.

Current edition approved Dec. 15, 2013 April 1, 2020. Published February 2014 June 2020. Originally approved in 1999. Last previous edition approved in 2005 2013 as F1956 – 99 (2005) F1956 - 13. DOI: 10.1520/F1956-13.10.1520/F1956-20.

² For referenced ASTM standards, visit the ASTM website, www.astm.org, or contact ASTM Customer Service at service@astm.org. For *Annual Book of ASTM Standards* volume information, refer to the standard's Document Summary page on the ASTM website.

3.1.4 *locking carabiner*—a carabiner with a locking mechanism ~~which~~ that reduces the possibility of a gate being opened inadvertently. A locking mechanism requires at least two different consecutive manual actions to open the gate (see ~~(one Appendix X2)~~ manual action to release the gate locking mechanism and one different manual action to open the carabiner gate).

3.1.5 *non-locking carabiner*—any carabiner that does not have a locking mechanism that reduces the possibility of a gate being opened inadvertently.

3.1.6 *rescue carabiner*—a carabiner intended for life support in rescue systems. It may be classified as ~~heavy-type~~ heavy-duty or ~~light-duty~~ standard-duty.

3.1.7 *standard-duty rescue carabiner*—carabiner that meets the specifications for a standard-duty rescue carabiner as defined in Section 9.

3.1.8 *ultimate strength*—~~the~~ maximum force sustained by a carabiner during an ultimate force test, prior to failure.

3.1.8.1 *failure*—~~the~~ point at which some part of the carabiner physically breaks or distorts to an extent that the test members are released.

4. Requirements

4.1 *Product information shall include the following items:*

4.1.1 *Manufacturer's or Distributor's Name or Logo*—A clear indication as to who is responsible for the primary manufacture or distribution, or both, of the product.

4.1.2 *Major Axis Gate Closed Ultimate Strength*—A clear indication as to the major axis gate closed strength by either symbol or pictorial representation.

4.1.3 *Minor Axis Gate Closed Ultimate Strength*—A clear indication as to the minor axis gate closed ultimate strength by either symbol or pictorial representation.

4.1.4 *Major Axis Gate Open Ultimate Strength*—A clear indication as to the major axis gate open ultimate strength by either symbol or pictorial representation.

4.1.5 *Lot Number*—A manufacturer's or distributor's lot number.

4.1.6 Either symbol or pictorial representation to read the manufacturer's or distributor's instructions.

4.2 Lettering, symbols, and pictorial representations shall be durably affixed to the carabiner.

4.3 Lettering, symbols, and pictorial representations shall be a minimum of 2 mm ($\frac{5}{64}$ in.) in height.

5. Significance and Use

5.1 *Gate Function Load Test*—This test verifies that the gate can be opened (with the gate locking mechanism in the unlocked position) and that the gate can not be opened (with the gate locking mechanism in the locked position) while loaded with Function Test Force #1 along the major axis.

5.2 *Gate Locking Mechanism Function Load Test*—This test verifies that the gate locking mechanism can be unlocked, after Function Test Force #2 has been applied along the major axis and released.

5.3 *Major Axis Gate Closed Function Load Test*—This test verifies that the gate functions as originally intended, after Function Test Force #3 has been applied and released.

5.4 *Major Axis Gate Closed Ultimate Strength Test*—This test is intended to show the ultimate strength of the carabiner in the major axis with the gate closed.

5.5 *Major Axis Gate Open Ultimate Strength Test*—This test is intended to show the ultimate strength of the carabiner in the major axis with the gate open.

5.6 *Minor Axis Gate Closed Ultimate Strength Test*—This test is intended to show the ultimate strength of the carabiner in the minor axis with the gate closed.

5.7 *Corrosion Test*—This test is intended to verify that the carabiner is produced from a corrosion-resistant material, or adequately covered with a protective coating.

6. Apparatus and Conditions

6.1 *Tensile Test Machine*—~~Apparatus~~—The ~~tension testing machine test apparatus~~ shall be maintained in good operation condition, used only in the proper loading range, and calibrated periodically in accordance with the latest revision of Practices E4.

6.2 *Test Fixtures and Supplies:*

6.2.1 There are four test pins required, two test pins with 6 ± 0.05 -mm radii and two test pins with 5 ± 0.05 -mm radii. Test pins must be AISI SAE Type 01 Tool Steel (commonly purchased as 01 Drill Rod) heat treated to a minimum Rockwell hardness, C scale 60. The mean surface roughness, R_a must not exceed $0.8 \mu\text{m}$ and the peak to valley height, R_{max} , must not exceed $6.3 \mu\text{m}$. The fixture must be designed to prevent the test pins from rotating and so that the carabiner is free to locate itself on the test pins when force is applied. See **Figs. 1 and 2**.

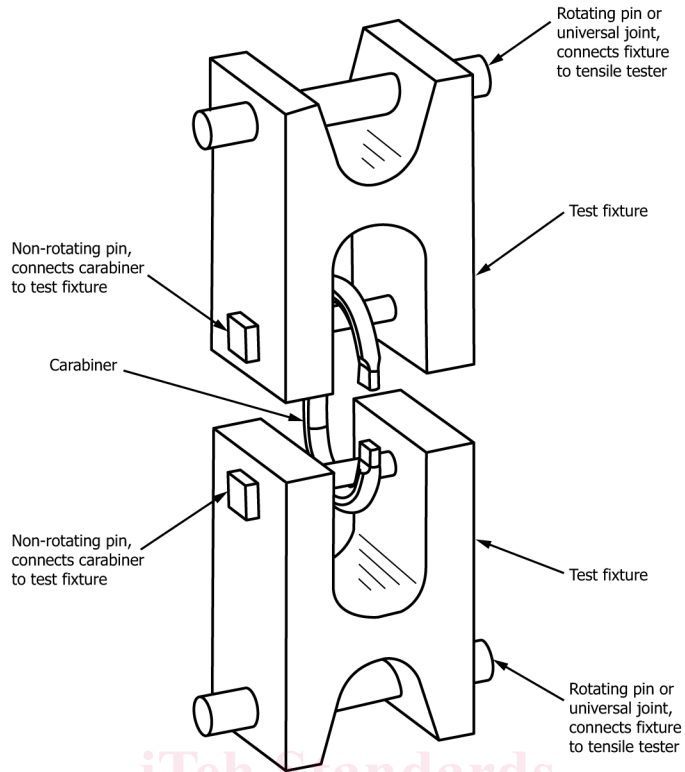

FIG. 1 Major Axis Test Setup

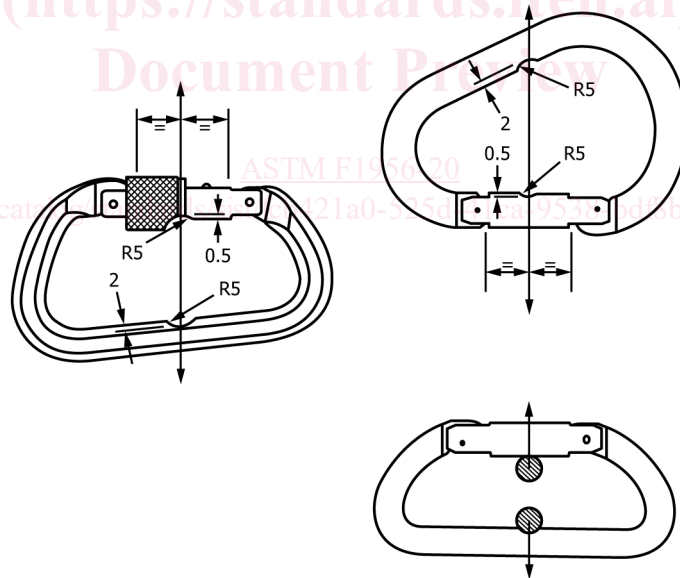

FIG. 2 Test-Fixture Minor Axis Test Pin Location

NOTE 1—Dimensions in millimeters.

NOTE 1—Test pin cross section is not required to be round. Any cross section necessary to prevent test pin failure or any design to prevent test pin rotation is acceptable, as long as the contact point (between test pin and carabiner) of the test pin has the specified radius, material type, hardness, and surface roughness.

6.2.2 Molybdenum-Based Grease.

6.3 Test Conditions:

6.3.1 The ambient temperature, test samples, test fixture, and supplies shall be between 15 and 23°C [59 and 73°F].

6.3.2 All six mechanical tests must be conducted with the force applied parallel to the gravitational pull of the earth.

7. Hazards

7.1 Carabiners may disengage or eject parts from the test fixture. Use a safety screen and wear safety glasses while testing. Do not perform these tests alone.

8. Sampling

8.1 *Sample Selection*—Randomly select the carabiners from the same production lot in accordance with 8.2.2. Each user of this test method may specify the lot size from which the carabiners are to be selected.

8.2 Number of Samples:

8.2.1 The same number of carabiners must be used for each of the tests in this specification.

8.2.2 A minimum of five carabiners will be used, in sequence, for the Gate Function Load Test, Gate Locking Mechanism Function Load Test, Major Axis Gate Closed Function Load Test, and Major Axis Gate Closed Ultimate Strength Test. A minimum of five carabiners will be used for the Major Axis Gate Open Ultimate Strength Test. A minimum of five carabiners will be used for the Minor Axis Gate Closed Ultimate Strength Test. A minimum of five carabiners will be used for the Corrosion Test.

8.2.3 Label the randomly selected carabiners 1 through X (X being the total number of carabiners selected).

9. Performance Specifications

9.1 Gate Function Load Test:

9.1.1 With the gate locking mechanism in the unlocked position and Function Test Force #1 applied along the major axis, each carabiner gate shall open and close as designed and with the same quality and performance as before the test. ~~The~~The use of tools or any device other than finger pressure is not ~~allowed~~allowed.

9.1.2 With the gate locking mechanism in the locked position and Function Test Force #1 applied along the major axis, the gate must not open. (The use of tools or any device other than finger pressure is not allowed.)

9.2 *Gate Locking Mechanism Function Load Test*—When a locking carabiner’s gate locking mechanism is advanced to its fully locked position, while the Function Test Force #2 is applied along the major axis. The gate locking mechanism must be able to be returned to its unlocked position after the force is removed. (The use of tools or any device other than finger pressure is not allowed.)

9.3 *Major Axis Gate Closed Function Load Test*—Each of the carabiners subjected to Function Test Force #3 shall show no evidence of distortion that impairs the designed function after the test is conducted.

9.4 *Major Axis Gate Closed Ultimate Strength Test*—Each of the carabiners subjected to this test shall have an ultimate strength equal to or greater than the major axis gate closed minimum ultimate strength listed in **Table 1**.

9.5 *Major Axis Gate Open Ultimate Strength Test*—Each of the carabiners subjected to this test shall have an ultimate strength equal to or greater than the major axis gate open minimum ultimate strength listed in **Table 1**.

9.6 *Minor Axis Gate Closed Ultimate Strength*—Each of the carabiners subjected to this test shall have an ultimate strength equal to or greater than the minor axis gate closed minimum ultimate strength listed in **Table 1**.

9.7 *Corrosion Test*—Each of the carabiners subjected to the corrosion test shall not have more than light-surface corrosion following the test. In addition, each carabiner gate shall open and close with the same quality and performance as before the test. (The use of tools or any device other than finger pressure is not allowed.) Furthermore, each gate locking mechanism must be able to move through its full range of travel with the same quality and performance as before the test. (The use of tools or any device other than finger pressure is not allowed.)

10. Procedure

10.1 Gate Function Load Test:

10.1.1 Open and close the gate and gate locking mechanism to feel the action of each carabiner prior to conducting this test. Record any interferences in the report.

TABLE 1 Function Test Forces and Minimum Ultimate Strengths

Carabiner Type	Function Test Forces ^A			Minimum Ultimate Strength		
	#1	#2	#3	Major Axis Gate Closed	Major Axis Gate Open	Minor Axis Gate Closed
Heavy-Duty Rescue carabiner	1.33 kN [300 lbf]	10.68 kN [2400 lbf]	26.69 kN [6000 lbf]	40.03 kN [9000 lbf], min	10.68 kN [2400 lbf], min	10.68 kN [2400 lbf], min
Light-Duty rescue carabiner	0.8 kN [180 lbf]	7 kN [1575 lbf]	14 kN [3145 lbf]	20 kN [4495 lbf], min	7 kN [1575 lbf], min	7 kN [1575 lbf], min
Standard-Duty rescue carabiner	0.8 kN [180 lbf]	7 kN [1575 lbf]	14 kN [3145 lbf]	20 kN [4495 lbf], min	7 kN [1575 lbf], min	7 kN [1575 lbf], min

^A± 5 %.