



Designation: C695 – 15 (Reapproved 2020)

Standard Test Method for Compressive Strength of Carbon and Graphite¹

This standard is issued under the fixed designation C695; the number immediately following the designation indicates the year of original adoption or, in the case of revision, the year of last revision. A number in parentheses indicates the year of last reapproval. A superscript epsilon (ϵ) indicates an editorial change since the last revision or reapproval.

This standard has been approved for use by agencies of the U.S. Department of Defense.

1. Scope

1.1 This test method covers the determination of the compressive strength of carbon and graphite at room temperature.

1.2 The values stated in inch-pound units are to be regarded as standard. The values given in parentheses are mathematical conversions to SI units that are provided for information only and are not considered standard.

1.3 *This standard does not purport to address all of the safety concerns, if any, associated with its use. It is the responsibility of the user of this standard to establish appropriate safety, health, and environmental practices and determine the applicability of regulatory limitations prior to use.*

1.4 *This international standard was developed in accordance with internationally recognized principles on standardization established in the Decision on Principles for the Development of International Standards, Guides and Recommendations issued by the World Trade Organization Technical Barriers to Trade (TBT) Committee.*

2. Referenced Documents

2.1 *ASTM Standards:*²

[E4 Practices for Force Verification of Testing Machines](#)

[E177 Practice for Use of the Terms Precision and Bias in ASTM Test Methods](#)

[E691 Practice for Conducting an Interlaboratory Study to Determine the Precision of a Test Method](#)

3. Terminology

3.1 *Definitions:*

3.1.1 *compressive strength, n*—property of solid material that indicates its ability to withstand a uniaxial compressive load.

¹ This test method is under the jurisdiction of ASTM Committee D02 on Petroleum Products, Liquid Fuels, and Lubricants and is the direct responsibility of Subcommittee D02.F0 on Manufactured Carbon and Graphite Products.

Current edition approved May 1, 2020. Published June 2020. Originally approved in 1971. Last previous edition approved in 2015 as C695 – 15. DOI: 10.1520/C0695-15R20.

² For referenced ASTM standards, visit the ASTM website, www.astm.org, or contact ASTM Customer Service at service@astm.org. For *Annual Book of ASTM Standards* volume information, refer to the standard's Document Summary page on the ASTM website.

4. Significance and Use

4.1 Carbon and graphite can usually support higher loads in compression than in any other mode of stress. This test, therefore, provides a measure of the maximum load-bearing capability of carbon and graphite objects.

5. Apparatus

5.1 *Test Machine*, conforming to Practice E4 and to the requirements for speed of testing prescribed in Section 8 of this test method.

5.2 *Spherical Bearing Blocks* attached to the upper or lower head of the machine in such a manner that the spherical surfaces are in full contact when not loaded. The center of curvative of the spherical surface shall lie on the surface that contacts the specimen and on the machine axis. The spherical surfaces shall be well-lubricated. The radius of the spherical surface shall be equal to or greater than the radius of the test specimen.

5.3 *Steel Contact Blocks* may be used above or below the specimen, or both, to protect fixture and test machine surfaces from damage, as illustrated in Fig. 1 and Fig. 2. Contact block surfaces shall be plane and parallel to within 0.0005 in./in. (0.0005 mm/mm).

5.4 All load-bearing machine and fixture surfaces shall have a minimum hardness of 45 HRC and surface finish of 16 μin . (0.4 μm) rms maximum. Surfaces in contact with the specimen shall be flat to less than 0.0005 in./in. (0.0005 mm/mm).

5.5 Examples of arrangements of the load train are shown schematically in Fig. 1 and Fig. 2.

6. Sampling

6.1 Samples may be taken from locations and orientations that satisfy the objectives of the test.

7. Test Specimen

7.1 The test specimen shall be a right cylinder with ends machined to yield planar and parallel faces. These faces shall be perpendicular to the cylindrical surface to within 0.001 in./in. (0.001 mm/mm) of diameter total indicator reading. All surfaces shall have a surface finish visually comparable

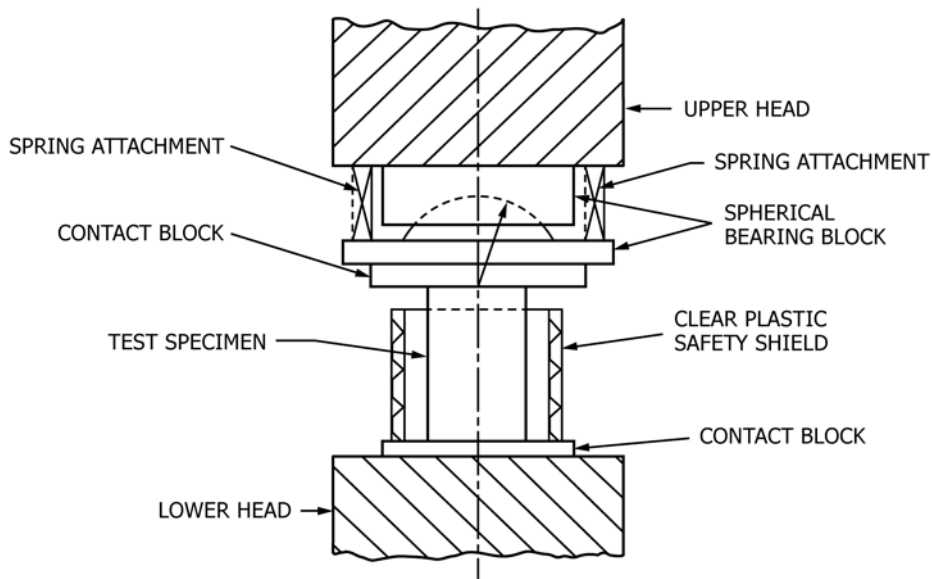

FIG. 1 Elements of Compressive Strength Load Train

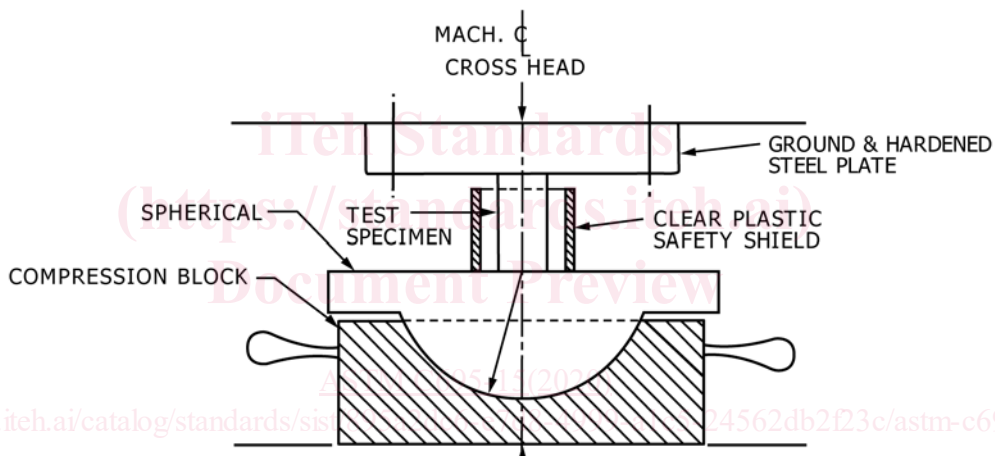

FIG. 2 Compressive Test Arrangement with Spherical Blocks on Bottom

to 32 $\mu\text{in.}$ (0.8 μm) rms or better. Reasonable care should be exercised to assure that all edges are sharp and without chips or other flaws.

7.2 The diameter of the test specimen shall be greater than ten times the maximum particle size of the carbon or graphite. The ratio of height to diameter may vary between 1.9 and 2.1. The recommended minimum test specimen size is $\frac{3}{8}$ in. (9.5 mm) diameter by $\frac{3}{4}$ in. (19 mm) high.

8. Procedure

8.1 Center the specimen in the machine between the contact surfaces. The deviation of the specimen axis from the machine axis shall be less than 5 % of the specimen diameter. Centering can be assisted by appropriate circles marked on the contact surfaces.

8.2 Place an appropriate guard around the specimen to deflect flying fragments at failure.

8.3 Apply the load continuously, at a constant rate of crosshead or platen movement, and without shock until ultimate failure. Choose the rate of movement so that average rupture time is greater than 30 s.

8.4 If the test machine is equipped with a load or strain pacing device, a constant load or strain rate may be used.

9. Calculation

9.1 Calculate the compressive strength of each specimen as follows:

$$C = W/A$$

where:

C = compressive strength of specimen, psi (or MPa),
 W = total load on the specimen at failure, lbf (or N), and
 A = calculated area of the gage section of the specimen, in.² (or mm²).