



Designation: E1235 – 12 (Reapproved 2020)<sup>ε1</sup>

# Standard Test Method for Gravimetric Determination of Nonvolatile Residue (NVR) in Environmentally Controlled Areas for Spacecraft<sup>1</sup>

This standard is issued under the fixed designation E1235; the number immediately following the designation indicates the year of original adoption or, in the case of revision, the year of last revision. A number in parentheses indicates the year of last reapproval. A superscript epsilon ( $\epsilon$ ) indicates an editorial change since the last revision or reapproval.

<sup>ε1</sup> NOTE—Editorial changes to Fig. 4 and Fig. 5 were made in June 2020.

## 1. Scope

1.1 This test method covers the determination of nonvolatile residue (NVR) fallout in environmentally controlled areas used for the assembly, testing, and processing of spacecraft.

1.2 The NVR of interest is that which is deposited on sampling plate surfaces at room temperature: it is left to the user to infer the relationship between the NVR found on the sampling plate surface and that found on any other surfaces.

1.3 *This standard does not purport to address all of the safety concerns, if any, associated with its use. It is the responsibility of the user of this standard to establish appropriate safety, health, and environmental practices and determine the applicability of regulatory limitations prior to use.*

1.4 The values stated in SI units are to be regarded as standard. No other units of measurement are included in this standard.

1.5 *This international standard was developed in accordance with internationally recognized principles on standardization established in the Decision on Principles for the Development of International Standards, Guides and Recommendations issued by the World Trade Organization Technical Barriers to Trade (TBT) Committee.*

## 2. Referenced Documents

2.1 *ASTM Standards:*<sup>2</sup>

D1193 Specification for Reagent Water

E1234 Practice for Handling, Transporting, and Installing Nonvolatile Residue (NVR) Sample Plates Used in Environmentally Controlled Areas for Spacecraft

F50 Practice for Continuous Sizing and Counting of Air-

borne Particles in Dust-Controlled Areas and Clean Rooms Using Instruments Capable of Detecting Single Sub-Micrometre and Larger Particles

2.2 *ISO Standards:*<sup>3</sup>

14644-1 Cleanrooms and Associated Controlled Environments—Part 1: Classification of Air Cleanliness

14644-2 Cleanrooms and Associated Controlled Environments—Part 2: Specifications for Testing and Monitoring to Prove Continued Compliance with ISO 14644-1

14951-3 Space Systems—Fluid Characteristics—Part 3: Nitrogen

2.3 *U.S. Federal Standard:*<sup>4</sup>

FED-STD-209E Airborne Particulate Cleanliness Classes in Cleanrooms and Clean Zones

2.4 *Institute of Environmental Sciences and Technology:*<sup>5</sup>

IEST-RP-CC001.3 HEPA and ULPA Filters

IEST-RP-CC007.1 Testing ULPA Filters

IEST-RP-CC034.1 HEPA and ULPA Filter Leak Tests

IEST-STD-CC1246 Product Cleanliness Levels and Contamination Control Program

2.5 *American National Standards Institute:*<sup>3</sup>

ANSI/ASME B46.1-2009 Surface Texture (Surface Roughness, Waviness, and Lay)

2.6 *Other:*

Industrial Ventilation, A Manual of Recommended Practice, Latest Edition<sup>6</sup>

SMC-TR-95-28, Nonvolatile Residue Solvent Replacement, U.S. Air Force Space and Missile Systems Center, 1 March 1995<sup>4</sup>

## 3. Terminology

3.1 *Definitions:*

<sup>1</sup> This test method is under the jurisdiction of ASTM Committee E21 on Space Simulation and Applications of Space Technology and is the direct responsibility of Subcommittee E21.05 on Contamination.

Current edition approved April 1, 2020. Published April 2020. Originally approved in 1988. Last previous edition approved in 2012 as E1235 – 12. DOI: 10.1520/E1235-12R20E01.

<sup>2</sup> For referenced ASTM standards, visit the ASTM website, www.astm.org, or contact ASTM Customer Service at service@astm.org. For *Annual Book of ASTM Standards* volume information, refer to the standard's Document Summary page on the ASTM website.

<sup>3</sup> Available from American National Standards Institute (ANSI), 25 W. 43rd St., 4th Floor, New York, NY 10036, <http://www.ansi.org>.

<sup>4</sup> Available from Standardization Documents Order Desk, Bldg. 4, Section D, 700 Robbins Ave., Philadelphia, PA, 19111-5094, Attn.: NPODS.

<sup>5</sup> Available from Institute of Environmental Sciences, 940 E. Northwest Highway, Mount Prospect, IL 60056.

<sup>6</sup> Available from Committee on Industrial Ventilation, PO Box 16153, Lansing, MI 48901.

3.1.1 *ISO Class N (airborne particulate cleanliness class)*, *n*—level of airborne particulate concentrations as defined in ISO 14644-1 and 14644-2, where  $10^N$  is the maximum allowable concentration (particles/m<sup>3</sup>).

3.1.1.1 *Discussion*—The considered particle sizes (lower threshold values) applicable for classification with ISO 14644-1 are limited to the range from 0.1 through 5 µm. Particles larger than 5 µm (macroparticles) may be expressed in accordance with Annex E of ISO 14644-1.

3.1.2 *FS209 class*, *n*—the level of cleanliness specified by the maximum allowable number of particles/ft<sup>3</sup> of air as defined in FED-STD-209E.

3.1.2.1 *Discussion*—This is provided for information and to facilitate the transition to the use of the ISO classification standard (ISO 14644-1).

3.1.3 *bumping*, *n*—uneven boiling of a liquid caused by irregular rapid escape of large bubbles of highly volatile components as the liquid mixture is heated or exposed to vacuum.

3.1.4 *clean area*, *n*—a general term that includes cleanrooms, controlled areas, good housekeeping areas, and other areas that have contamination control by physical design and specified operating procedures.

3.1.5 *clean zone*, *n*—a defined space in which the contamination is controlled to meet specified cleanliness levels.

3.1.5.1 *Discussion*—The clean zone may be open or enclosed and may or may not be located within a cleanroom.

3.1.6 *contaminant*, *n*—unwanted molecular and particulate matter that could affect or degrade the performance of the components upon which they reside.

3.1.7 *contamination*, *n*—a process of contaminating.

3.1.8 *controlled area*, *n*—an environmentally controlled area, operated as a cleanroom, with two prefilter stages but without the final stage of HEPA (or better) filters used in cleanrooms.

3.1.8.1 *Discussion*—Only rough filters (50 to 60 % efficiency) and medium efficiency filters (80 to 85 % efficiency) are required for a controlled area. The maximum allowable airborne particle concentrations are ISO Class 8.5 (FS209 Class 283 000) area for particles 0.5 µm and ISO Class 8 (FS209 Class 100 000) for particles 5.0 µm.

3.1.9 *environmentally controlled areas*, *n*—a general term that includes cleanrooms, controlled areas, good housekeeping areas, and other enclosures that are designed to provide an environment suitable for people or products.

3.1.9.1 *Discussion*—The environmental components that are controlled include, but are not be limited to, air purity, temperature, humidity, materials, garments, and personnel activities.

3.1.10 *facility (clean facility)*, *n*—the total real property required to accomplish the cleanroom functions.

3.1.10.1 *Discussion*—In addition to the cleanroom and associated clean areas, this includes utility rooms, storage areas, offices, lockers, washrooms, and other areas that do not necessarily require precise environmental control.

3.1.11 *good housekeeping area*, *n*—an environmentally controlled area without quantitative cleanliness requirements but maintained in a visibly clean condition.

3.1.11.1 *Discussion*—Office, laboratory, and storage areas with air conditioning and janitorial service are typical of good housekeeping areas.

3.1.12 *HEPA (high efficiency particulate air) filter*, *n*—a filter for air with a removal efficiency in excess of 99.97 % for 0.3-µm particles.

3.1.12.1 *Discussion*—For this application, HEPA filters shall meet the requirements of IEST-RP-CC001.3, IEST-RP-CC007.1, IEST-RP-CC034.1, and 6.4 of this test method.

3.1.13 *molecular contaminant—nonparticulate contaminant*, *n*—nonparticulate matter.

3.1.13.1 *Discussion*—The molecular contaminant may be in a gaseous, liquid, or solid state. It may be uniformly or nonuniformly distributed or be in the form of droplets. Molecular contaminants account for most of the NVR.

3.1.14 *NVR (nonvolatile residue)*, *n*—quantity of residual soluble, suspended, and particulate matter remaining after the controlled evaporation of a volatile liquid at a specified temperature.

3.1.14.1 *Discussion*—The liquid is usually filtered through a membrane filter, of a specified size, before evaporation to control the sizes of particles in the NVR. The process used to determine the NVR may affect the quantitative measurement. Process factors include filter size, solvent, and the evaporation temperature and atmosphere. For this reason, the process must be defined as it is in this test method.

3.1.15 *particle (particulate contaminant)*, *n*—a piece of matter in a solid or liquid (droplet) state with observable length, width, and thickness.

3.1.16 *particle size*, *n*—(1) the apparent maximum linear dimension of a particle in the plane of observation, as observed with an optical microscope; (2) the equivalent diameter of a particle detected by automatic instrumentation. The equivalent diameter is the diameter of a reference sphere having known properties and producing the same response in the sensing instrument as the particle being measured; (3) the diameter of a circle having the same area as the projected area of a particle, in the plane of observation, observed by image analysis; and (4) the size defined by the measurement technique and calibration procedure.

3.1.16.1 *Discussion*—Because the particle size is defined by the measurement method, the measurement method and size definition should be stated when specifying or describing particle size.

3.1.17 *azeotropic mixture*, *n*—a solution of two or more liquids, the composition of which does not change upon distillation. Also known as *azeotrope*.

## 4. Summary of Test Method

4.1 A stainless steel plate is exposed within an environmentally controlled area for a known time. It is handled and transported in accordance with Practice E1234.

4.2 The plate is rinsed with a high purity solvent.

4.3 The solvent is filtered into a beaker, transferred to a preweighed container, and evaporated at or near room temperature, with a final drying at 35 °C for 30 min. Alternative evaporation methods are included.

4.4 The NVR sample is weighed after it has equilibrated to room temperature and humidity conditions.

4.5 A blank stainless steel NVR plate is concurrently treated identically to each group of samples to determine solvent background and handling effects.

4.6 A reagent blank for each group of samples is determined.

4.7 Each NVR sample, 0.5 mg or greater, is retained for organic analysis by infrared spectrometry, or other techniques, to identify contaminants.

## 5. Significance and Use

5.1 The NVR determined by this test method is that amount that can reasonably be expected to exist on hardware exposed in environmentally controlled areas.

5.2 The evaporation of the solvent at or near room temperature is to quantify the NVR that exists at room temperature.

5.3 Numerous other methods are being used to determine NVR. This test method is not intended to replace methods used for other applications.

## 6. Apparatus and Materials

6.1 *Analytical Microbalance*, semimicro 5 place, with 30 g or greater tare, no greater than 0.01-mg readability, and  $\pm 0.01$ -mg precision.<sup>7</sup>

6.2 *HEPA Filtered*, ISO Class 5 (FS209 Class 100), or better environment, as defined in ISO 14644-1, unidirectional airflow, clean workstation.

6.3 *HEPA Filtered*, ISO Class 5 (FS209 Class 100), or better environment, as defined in ISO 14644-1, unidirectional airflow, exhausting work station, with 100 % exhaust for handling solvents.

NOTE 1—The exhausting work station is recommended to prevent solvent vapors from entering the laboratory area (see Industrial Ventilation, a Manual of Recommended Practice).

NOTE 2—Verify that the airborne particle concentrations in the work stations are ISO Class 5 FS209 Class 100, or better, per ISO 14644-1, when tested in accordance with Practice F50.

NOTE 3—Verify NVR levels in the work stations are acceptable using the procedures in this standard.

6.4 *HEPA Filters*—All HEPA filters shall be constructed of low outgassing, corrosion-resistant, and fire-resistant materials such as Grade 1 in IEST-RP-CC001.3. Filters with stainless steel or aluminum frames should be considered. The filters shall not be tested with DOP (dioctylphthalate) or other liquid aerosols. Ambient air and solid aerosol test methods are acceptable alternatives to the DOP test. Applicable test methods from IEST-RP-CC007.1 and IEST-RP-CC034.1 shall be considered.

6.5 *Vacuum Filtration System*, consisting of a 47-mm-diameter membrane filter funnel<sup>8</sup> and vacuum pump that will provide a pressure of 30 kPa (250 torr) (a vacuum of 20 in. Hg). See Fig. 1.

6.6 *Solvent-Resistant Filter*, 47-mm diameter,<sup>9</sup> 0.2- $\mu$ m pore size (nominal) fluorocarbon.

6.7 *Tweezers or Hemostat*, stainless steel or coated with TFE-fluorocarbon.

6.8 *Beakers*, low-form, glass, 250 mL, etched with an identification number.

6.9 *Evaporating Dish (Petri Dish)*, borosilicate glass, approximately 15 g in mass, 60-mm diameter by 12 mm deep, and etched with an identification number.

6.10 *Liquid Laboratory Detergent*.

6.11 *Gloves*, solvent compatible and resistant.<sup>10</sup> (**Warning**—Gloves shall be used to protect the hands from accidental spills of the NVR solvent and minimize contamination of exposed samples. Gloves shall be selected to meet local safety and contamination control requirements.)

6.12 *NVR Plate*, Type 316 corrosion-resistant steel with an area of approximately 0.1 m<sup>2</sup> (1 ft<sup>2</sup>). The plate shown in Fig. 2 has been found to be satisfactory. The finish of the sampling surface shall be 0.80  $\mu$ m (32  $\mu$ in.) or better per ANSI/ASME B46.1. The plate shall be electropolished and engraved with an identification number.

6.13 *NVR Plate Cover*, Type 316 corrosion-resistant steel. The cover shown in Fig. 3 has been found to be satisfactory. The finish shall be 0.80  $\mu$ m (32  $\mu$ in.) or better per ANSI/ASME B46.1. The cover shall be electropolished and engraved with an identification number.

<sup>8</sup> Gelman filter funnel P/N 4012/Fisher filtrator assembly Cat. No. 09-788 and Millipore Cat. No. XX1504700 filtration assembly have been found to be satisfactory. Other suitable filtration apparatus may be used.

<sup>9</sup> Millipore Corp. Fluoropore filter Cat. No. FGLP 04700, and Gelman Sciences, Inc. Prod. 66143 PTFE have been found to be satisfactory. Other equivalent solvent resistant filters may be used.

<sup>10</sup> Pioneer green nitrile gloves, Catalog No. A10-1, have been found to be satisfactory.

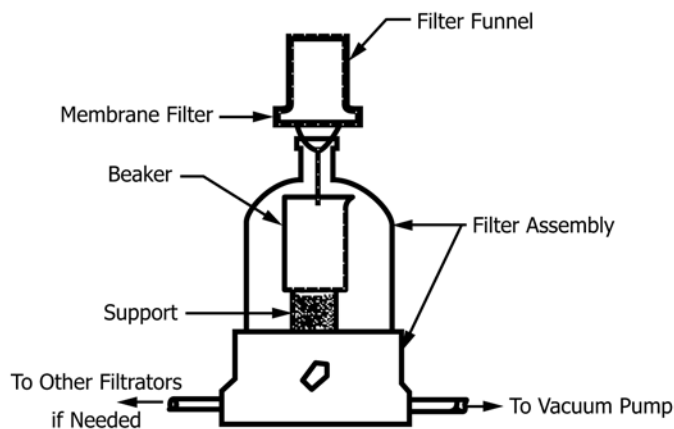

FIG. 1 Vacuum Filtration Apparatus

<sup>7</sup> Sartorius Model R180D, or equivalent.

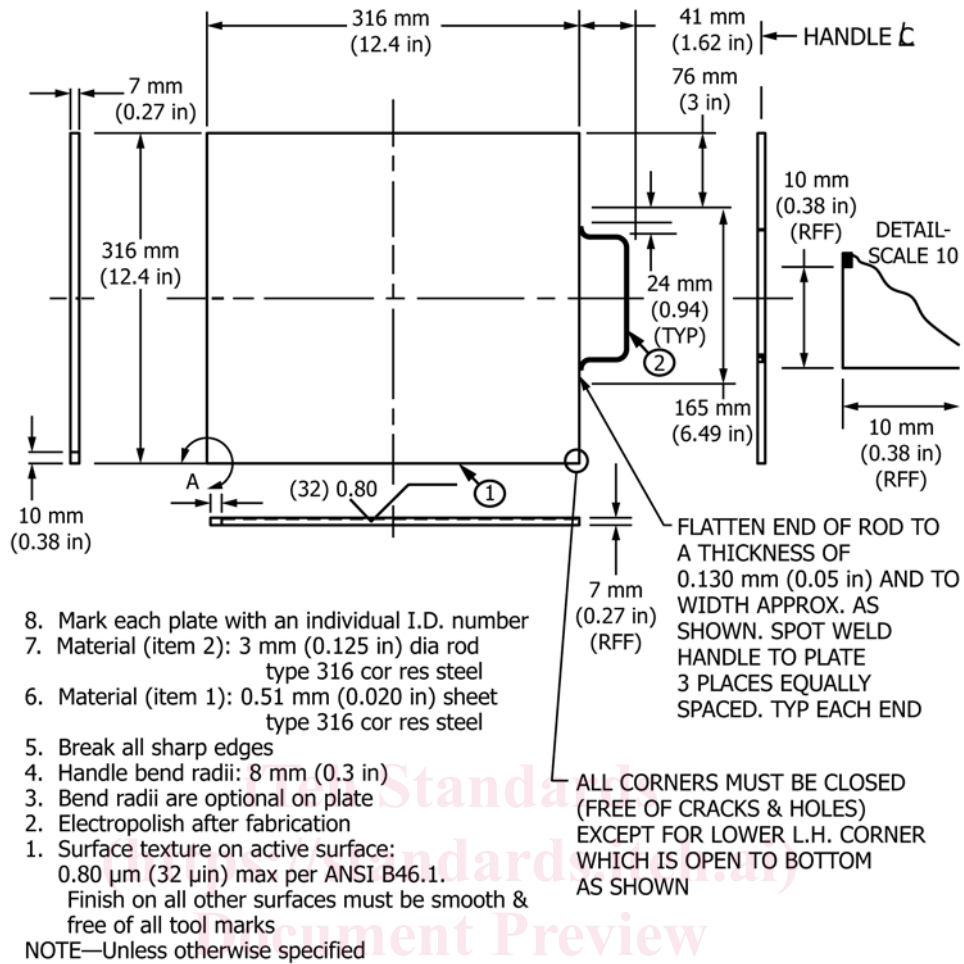

FIG. 2 NVR Collector Plate

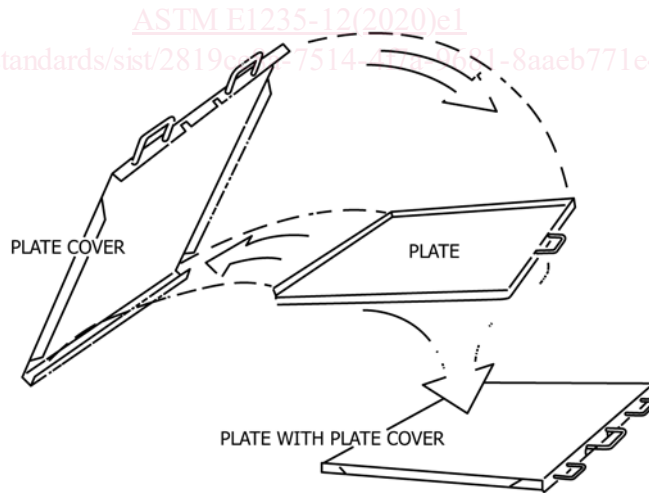

FIG. 3 NVR Plate Cover

6.14 *Oil-Free Aluminum Foil*<sup>11</sup>, to cover the NVR plate if the cover (6.12) is not used.

NOTE 4—The hard cover (6.13) is preferred for ease of handling and

possible tearing of the foil resulting in contamination of the NVR plate.

6.15 *Noncontaminating Nylon Bag* to enclose each covered NVR plate.<sup>12</sup>

<sup>11</sup> Fed Spec. Food Service Grade aluminum foil, oil free, Federal Stock No. 8135-00-724-0551 has been found to be satisfactory.

<sup>12</sup> Nylon 6 (heat-sealable Capran 980 from Allied Chemical) has been found to be satisfactory.



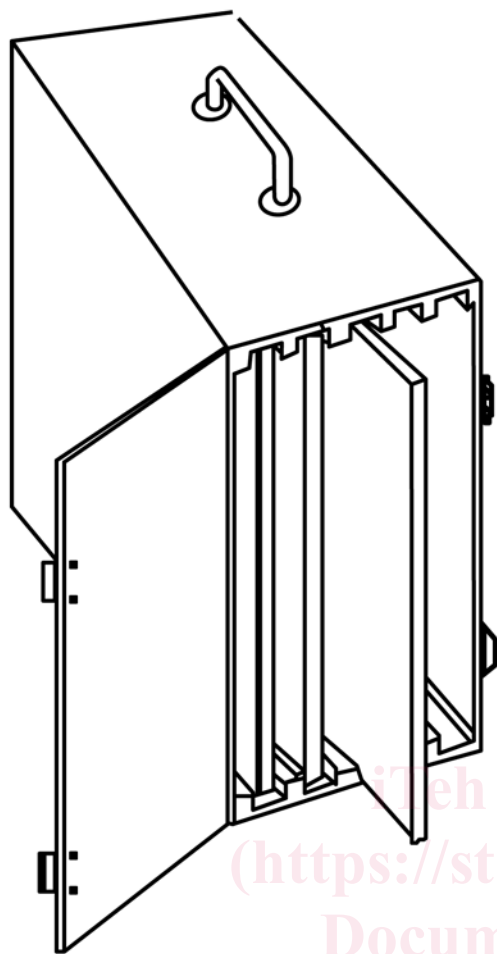

FIG. 4 NVR Plate Carrier

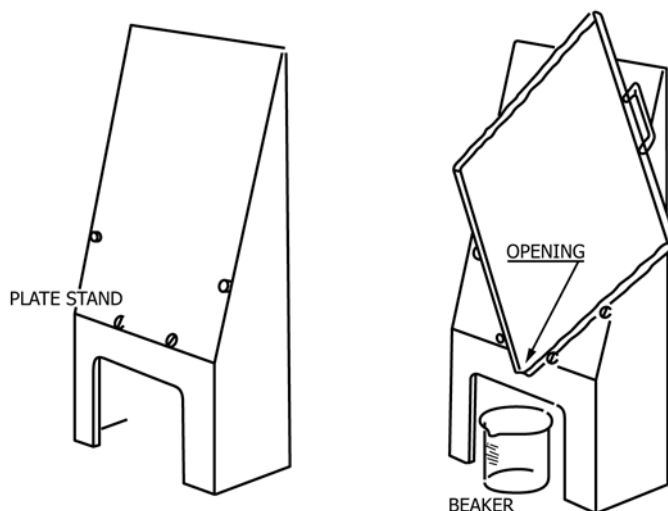

FIG. 5 NVR Plate Stand

prevent release into the atmosphere, protect the vacuum pump, and allow recycling of the solvent.

6.21 Automatic, controlled environment (nitrogen atmosphere) evaporator capable of controlling to a temperature of 37 °C<sup>13</sup> (Method 3). Fig. 7 shows a typical arrangement.

6.22 600-mL (450-mL capacity) graduated, borosilicate glass tubes, 75-mm diameter, 150 mm high with 2-mL stems, to fit in the temperature controlled block in the evaporator<sup>14</sup> (Method 3).

## 7. Reagents

7.1 *Purity of Reagents*—Reagent grade chemicals shall be used in all tests. Unless otherwise indicated, it is intended that all reagents shall conform to the specifications of the Committee on Analytical reagents of the American Chemical Society, when such specifications are available.<sup>15</sup>

7.2 *Purity of Water*—Deionized, organic-free water such as reagent water, Type II in accordance with Specification **D1193** with a minimum resistivity of 1.0 MΩ-cm.

7.3 *Acetone*, reagent grade.

7.4 *Methanol Absolute*, reagent grade.

7.5 *Nitrogen*, ISO 14951-3, Type I (gaseous), Grade B or better.

7.6 *NVR Solvent* (see **Note 5**)—Methylene chloride, used in Test Method E1235-95, is toxic<sup>16</sup>, and is being phased out for

<sup>13</sup> RapidVap N<sub>2</sub>, Model 79100, evaporation system, with No. 79065 sample block, Labconco Corp., 8811 Prospect Ave., Kansas City, MO 641132-2696 has been found to be satisfactory.

<sup>14</sup> Catalog No. 79138-00 borosilicate glass tubes (6) with 2-mL stems to fit the RapidVap Model 79100 has been found to be satisfactory.

<sup>15</sup> *Reagent Chemicals, American Chemical Society Specifications*, American Chemical Society, Washington, DC. For suggestions on the testing of reagents not listed by the American Chemical Society, see *Analar Standards for Laboratory Chemicals*, BDH Ltd., Poole, Dorset, U.K., and the *United States Pharmacopeia and National Formulary*, U.S. Pharmacopeial Convention, Inc. (USPC), Rockville, MD.

<sup>16</sup> Material Safety Data Sheet No. 310, Genium Publishing Corp., 1145 Catalyn St., Schenectady, NY 12303.

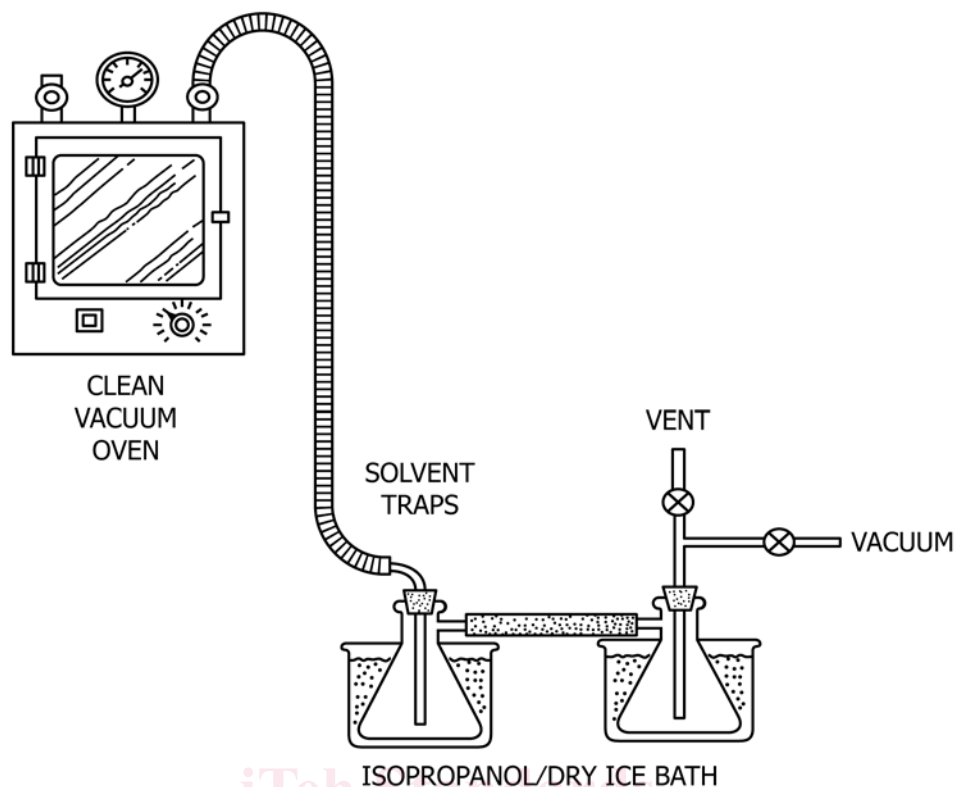

FIG. 6 Vacuum Oven Evaporation System

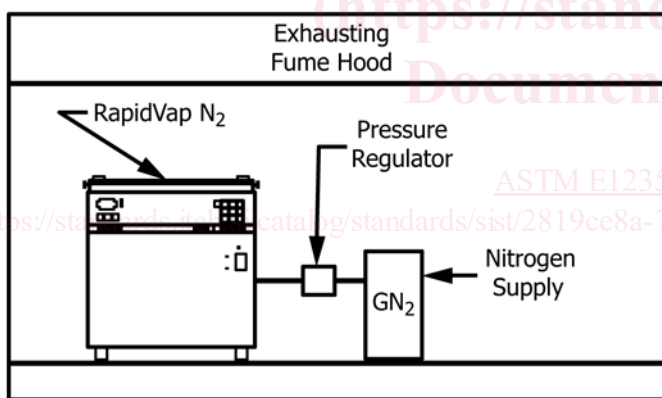

FIG. 7 Automatic Evaporator System

many applications. Methylene chloride has been replaced in this revision of Test Method E1235. The replacement solvents were selected based on tests and analyses performed by The Aerospace Corporation and described in SMC-TR-95-28. The following solvents are acceptable:

7.6.1 *HPLC (High-Purity Liquid Chromatography) Grade Ethyl Acetate*<sup>17</sup>—The solvent shall be certified to contain <1-ppm (<1-mg/L) NVR using the procedure in Section 10.

NOTE 5—Ethyl acetate is an organic solvent, and as such, presents some

<sup>17</sup> Burdick & Jackson catalog No. 100, B&J Brand ethyl acetate has been found to be satisfactory.

degree of physical and health hazard. Use of ethyl acetate should be according to the recommendations provided in the Material Safety Data Sheet.<sup>18</sup>

7.6.2 *Cyclohexane/Ethyl Acetate Azeotrope Mixture*—This is an azeotrope consisting of 44 to 46 % cyclohexane<sup>19</sup> and 54 % ethyl acetate<sup>20</sup> by mass or 53 % cyclohexane and 47 % ethyl acetate by volume.<sup>21,22</sup> The solvent shall be certified to contain <1-ppm (<1-mg/L) NVR using the procedure in Section 10.

NOTE 6—Cyclohexane/ethyl acetate azeotrope is an organic solvent, and as such, presents some degree of physical and health hazard. Use of cyclohexane should be according to the recommendations provided in the Material Safety Data Sheet.<sup>23</sup> No commercial sources have been located for this solvent mixture. Users have blended their own mixtures using cyclohexane and ethyl acetate.

NOTE 7—Other solvents may be used to perform these measurements. The use of different solvents may be required because of incompatibilities of these solvents with surfaces being sampled or for other operational reasons; however, the results may be different because the performance characteristics of the solvents are different. This means that comparisons

<sup>18</sup> Material Safety Data Sheet No. 437, Genium Publishing Corp., 145 Catalyn St., Schenectady, NY 12303.

<sup>19</sup> Burdick & Jackson catalog No. 053, B&J Brand cyclohexane has been found to be satisfactory.

<sup>20</sup> Burdick & Jackson catalog No. 100, B&J Brand ethyl acetate has been found to be satisfactory.

<sup>21</sup> CRC Handbook of Chemistry and Physics, 52nd Ed, The Chemical Rubber Co., Cleveland, OH.

<sup>22</sup> Data Source For Homogenous Azeotropes at the University of Edinburgh.

<sup>23</sup> Material Safety Data Sheet No. B&J 0053, Burdick & Jackson.