



Designation: ~~D5133~~—~~20~~ D5133 – 20a

# Standard Test Method for Low Temperature, Low Shear Rate, Viscosity/Temperature Dependence of Lubricating Oils Using a Temperature- Scanning Technique<sup>1</sup>

This standard is issued under the fixed designation D5133; the number immediately following the designation indicates the year of original adoption or, in the case of revision, the year of last revision. A number in parentheses indicates the year of last reappraisal. A superscript epsilon ( $\epsilon$ ) indicates an editorial change since the last revision or reappraisal.

## 1. Scope\*

1.1 This test method covers the measurement of the apparent viscosity of engine oil at low temperatures.

1.2 A shear rate of approximately  $0.2 \text{ s}^{-1}$  is produced at shear stresses below 100 Pa. Apparent viscosity is measured continuously as the sample is cooled at a rate of  $1 \text{ }^\circ\text{C/h}$  over the range  $-5 \text{ }^\circ\text{C}$  to  $-40 \text{ }^\circ\text{C}$ , or to the temperature at which the viscosity exceeds  $40\,000 \text{ mPa}\cdot\text{s}$  (cP).

1.3 The measurements resulting from this test method are viscosity, the maximum rate of viscosity increase (Gelation Index), and the temperature at which the Gelation Index occurs.

1.4 Applicability to petroleum products other than engine oils has not been determined in preparing this test method.

1.5 The values stated in SI units are to be regarded as standard. No other units of measurement are included in this standard.

1.6 *This standard does not purport to address all of the safety concerns, if any, associated with its use. It is the responsibility of the user of this standard to establish appropriate safety, health, and environmental practices and determine the applicability of regulatory limitations prior to use.*

1.7 *This international standard was developed in accordance with internationally recognized principles on standardization established in the Decision on Principles for the Development of International Standards, Guides and Recommendations issued by the World Trade Organization Technical Barriers to Trade (TBT) Committee.*

## 2. Referenced Documents

2.1 *ASTM Standards:*<sup>2</sup>

[D341 Practice for Viscosity-Temperature Equations and Charts for Liquid Petroleum or Hydrocarbon Products](#)

[D3829 Test Method for Predicting the Borderline Pumping Temperature of Engine Oil](#)

[D4684 Test Method for Determination of Yield Stress and Apparent Viscosity of Engine Oils at Low Temperature](#)

[D6299 Practice for Applying Statistical Quality Assurance and Control Charting Techniques to Evaluate Analytical Measurement System Performance](#)

[D7962 Practice for Determination of Minimum Immersion Depth and Assessment of Temperature Sensor Measurement Drift](#)

[E644 Test Methods for Testing Industrial Resistance Thermometers](#)

## 3. Terminology

3.1 *Definitions:*

3.1.1 *apparent viscosity, n*—the viscosity obtained by use of this test method.

3.1.1.1 *Discussion*—

See 3.1.7 for definition of viscosity and units.

<sup>1</sup> This test method is under the jurisdiction of ASTM Committee D02 on Petroleum Products, Liquid Fuels, and Lubricants and is the direct responsibility of Subcommittee D02.07 on Flow Properties.

Current edition approved ~~May 1, 2020~~ June 1, 2020. Published June 2020. Originally approved in 1990. Last previous edition approved in ~~2019~~2020 as ~~D5133—19~~D5133 – 20. DOI: ~~10.1520/D5133-20~~10.1520/D5133-20A.

<sup>2</sup> For referenced ASTM standards, visit the ASTM website, www.astm.org, or contact ASTM Customer Service at service@astm.org. For *Annual Book of ASTM Standards* volume information, refer to the standard's Document Summary page on the ASTM website.

\*A Summary of Changes section appears at the end of this standard

3.1.2 *digital contact thermometer (DCT), n*—an electronic device consisting of a digital display and associated temperature sensing probe.

3.1.2.1 *Discussion*—

This device consists of a temperature sensor connected to a measuring instrument; this instrument measures the temperature-dependent quantity of the sensor, computes the temperature from the measured quantity, and provides a digital output. This digital output goes to a digital display or recording device, or both, that may be internal or external to the device.

3.1.2.2 *Discussion*—

The devices are often referred to as “digital thermometers,” however the term includes devices that sense temperature by means other than being in physical contact with the media.

3.1.2.3 *Discussion*—

PET is an acronym for portable electronic thermometers, a subset of digital contact thermometers (DCT).

3.1.3 *Newtonian oil, n*—an oil ~~that, or fluid that~~ at a given ~~temperature, temperature~~ exhibits a constant viscosity at all shear rates or shear stresses.

3.1.4 *non-Newtonian oil, n*—an oil ~~that, or fluid that~~ at a given ~~temperature, temperature~~ exhibits a viscosity that varies with changing shear stress or shear rate.

3.1.5 *shear rate, n*—velocity gradient perpendicular to the direction of flow.

3.1.5.1 *Discussion*—

The SI unit for shear rate is the reciprocal second (1/s; also s<sup>-1</sup>).

3.1.6 *shear stress, n*—force per unit area in the direction of flow.

3.1.6.1 *Discussion*—

The SI unit for shear stress is the Pascal (Pa).

3.1.7 *viscosity, n*—~~that property of a fluid which resists flow; the ratio between the applied shear stress and rate of shear which is sometimes called the coefficient of dynamic viscosity and is a measure of the resistance to flow of the liquid.~~

3.1.7.1 *Discussion*—

~~Viscosity is defined as the ratio of the applied shear stress (force causing flow) and the shear rate (resultant velocity of flow per unit distance from a stationary surface wet by the fluid). Mathematically expressed:~~

$$\text{viscosity} = \text{shear stress/shear rate or, symbolically, } \eta = \tau/\dot{\gamma} \quad (1)$$

in which the symbols in the second portion of Eq 1 are defined by the terms in the first portion of the equation. The SI unit for viscosity used herein is milliPascal seconds (mPa·s).

3.2 *Definitions of Terms Specific to This Standard:*<sup>3</sup>

3.2.1 *air-binding oils*—those engine oils whose borderline pumping temperatures are determined by a combination of gelation and viscous flow.

3.2.2 *borderline pumping temperature, n*—that temperature at which an engine oil may have such poor flow characteristics that the engine oil pump may not be capable of supplying sufficient lubricant to the engine.

3.2.3 *calibration oil, n*—Newtonian oils developed and used to calibrate the viscometer drive module over the viscosity range required for this test method.

<sup>3</sup> The sole source of supply of the equipment and materials known to the committee at this time is Tannas Co., 4800 James Savage Rd., Midland, MI 48642. If you are aware of alternative suppliers, please provide this information to ASTM International Headquarters. Your comments will receive careful consideration at a meeting of the responsible technical committee,<sup>1</sup> which you may attend.

### 3.2.3.1 Discussion—

these calibration oils are specially blended to give sufficient sensitivity and range for the special viscometer head used.

3.2.4 *computer-programmed automated analysis, n*—use of modern techniques for acquiring analog data, converting these to digital values and using this information to automatically record and analyze torque output from the viscometer drive module and to render this information into tabular data and plotted relationships.

3.2.4.1 *analog-to-digital (A-D) converter, n*—a device for converting continuously produced electrical signals into discrete numerical values capable of being analyzed by computer technology.

3.2.5 *critical pumpability temperature, n*—the temperature in the programmable cooling bath at which an oil reaches a chosen critical pumpability viscosity (see 3.2.6).

3.2.6 *critical pumpability viscosity, n*—that apparent viscosity believed to cause pumpability problems in an engine. This apparent viscosity is chosen to test an oil for its critical pumpability temperature.

3.2.7 *flow-limited oils, n*—those oils whose borderline pumping temperatures are determined by viscous flow.

3.2.8 *gelation, n*—a rheological condition of an oil characterized by a marked increase in the flow resistance over and above the normal exponential increase of viscosity with decreasing temperature, particularly at lower shear stresses and temperatures.

### 3.2.8.1 Discussion—

Gelation has been attributed to a process of nucleation and crystallization of components of the engine oil and the formation of a structure.<sup>4</sup>

3.2.9 *Gelation Index, n*—the maximum value of the incremental ratio

$$-\frac{[(\log \log \eta_1) - (\log \log \eta_2)]}{(\log T_1 - \log T_2)} \quad (2)$$

(in which  $\eta$  is dynamic viscosity and  $T$  is in degrees Kelvin) over the temperature range scanned when the incremental decrease in temperature is 1 K.

### 3.2.9.1 Discussion—

The technique of deriving Gelation Index was first developed and practiced<sup>5</sup> collecting information from a strip-chart recording and applying the empirical MacCoull-Walther-Wright equation (Test Method D341). For further information, see Appendix X1.

3.2.10 *Gelation Index reference oils, n*—non-Newtonian oils chosen to give certain levels of Gelation Index as a check on instrument performance.<sup>3</sup>

3.2.11 *Gelation Index temperature, n*—the temperature ( $t_2$  in Eq 2) in degrees Celsius at which the Gelation Index occurs.

3.2.12 *programmable cooling bath, n*—a liquid or dry block (referred to as direct cool) bath having a temperature controller capable of being programmed to run the calibration and the analysis portions of the test method within the temperature tolerances listed.

3.2.13 *temperature controller, n*—a programmable device which, when properly programmed, ramps the temperature upward or downward at a chosen rate or series of steps while simultaneously controlling temperature excursions.

3.2.13.1 *calibration program, n*—a program to run the required series of temperatures at which the torque values necessary to calibrate the viscometer drive module are collected and analyzed.

3.2.13.2 *hold program, n*—a program to reach and hold the programmable cooling bath at  $-5^\circ\text{C}$ .

3.2.13.3 *test program, n*—a program to run the test oil analysis at  $1^\circ\text{C/h}$  temperature decrease.

3.2.14 *test cell, n*—the combination of the rotor and stator. Critical elements of the test cell are sketched in Fig. 1.

3.2.14.1 *rotor, n*—a titanium rotor sized to give a compromise of sensitivity and range to the determination of viscosity and gelation using this test method.

(1) *stator, n*—a precision-bore borosilicate glass or stainless steel tube, to which a measured amount of oil is added for the test and within which the specially-made rotor turns.

(2) *stator collar, n*—a clamp for the stator which also positions it on the test cell alignment device.

3.2.15 *sample preheater, n*—a water bath, air bath or oven, or dry bath (integrated or separate) to heat the samples for 1.5 h to  $2.0\text{ h}$  at  $90^\circ\text{C} \pm 2^\circ\text{C}$  before testing.

<sup>4</sup> *Symposium on Low Temperature Lubricant Rheology Measurement and Relevance to Engine Operation, ASTM STP 1143*, Rhodes, R. B., ed., ASTM, 1992.

<sup>5</sup> Selby, T.W., "The Use of the Scanning Brookfield Technique to Study the Critical Degree of Gelation of Lubricants at Low Temperatures", SAE Paper 910746, Society of Automotive Engineers, 1991.

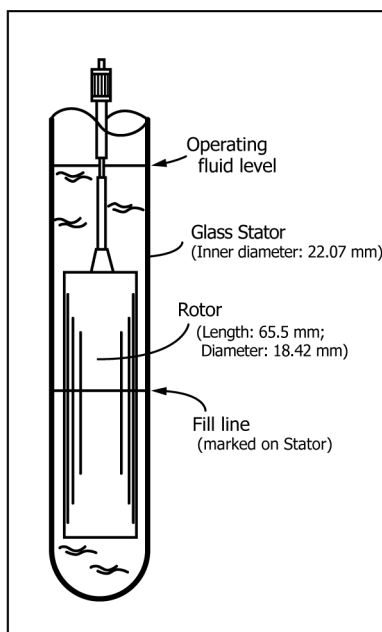

FIG. 1 Test Cell

3.2.16 *test cell alignment device*<sup>6</sup>, *n*—a special device used to support the viscometer drive module while maintaining the stator and the rotor coaxial and vertical in regard to the viscometer driveshaft. Later designs permit dry gas into the cell to prevent moisture and frost buildup.

3.2.17 *test oil*, *n*—any oil for which apparent viscosity is to be determined using the procedure described by this test method.

3.2.18 *viscometer drive module*, *n*—the rotor drive and torque-sensing component of a rotational viscometer.

3.2.19 *viscometer module support*, *n*—a part of the test cell alignment device supporting the viscometer drive module.

#### 4. Summary of Test Method

4.1 After preheating approximately 20 mL of the test oil in a glass stator at 90 °C for 1.5 h to 2.0 h, the test cell containing the test oil is attached to a suitable viscometer drive module and the test cell immersed in a programmable cooling bath and cooled at 1 °C/h over the temperature range of -5 °C to -40 °C. Data from the viscometer drive module is collected and fed to a computerized data assimilation program to determine the Gelation Index, Gelation Index temperature, and Critical Pumpability temperature for a selected viscosity such as 30 000 mPa·s or 40 000 mPa·s (cP).

#### 5. Significance and Use

5.1 *Significance of Low-Temperature, Low Shear Rate, Engine Oil Rheology*—The low-temperature, low-shear viscometric behavior of an engine oil determines whether the oil will flow to the sump inlet screen, then to the oil pump, then to the sites in the engine requiring lubrication in sufficient quantity to prevent engine damage immediately or ultimately after cold temperature starting.

5.1.1 Two forms of flow problems have been identified,<sup>4</sup> flow-limited and air-binding behavior. The first form of flow restriction, flow-limited behavior, is associated with the oil's viscosity; the second, air-binding behavior, is associated with gelation.

5.2 *Significance of the Test Method*—The temperature-scanning technique employed by this test method was designed to determine the susceptibility of the engine oil to flow-limited and air-binding response to slow cooling conditions by providing continuous information on the rheological condition of the oil over the temperature range of use.<sup>4,5,7</sup> In this way, both viscometric and gelation response are obtained in one test.

NOTE 1—This test method is one of three related to pumpability related problems. Measurement of low-temperature viscosity by the two other pumpability Test Methods D3829 and D4684, hold the sample in a quiescent state and generate the apparent viscosity of the sample at shear rates ranging up to 15 sec<sup>-1</sup> and shear stresses up to 525 Pa at a previously selected temperature. Such difference in test parameters (shear rate, shear stress, sample

<sup>6</sup> The test cell alignment device is covered by patents. Interested parties are invited to submit information regarding the identification of alternatives to this patented item to ASTM International Headquarters. Your comments will receive careful consideration at a meeting of the responsible technical committee, which you may attend.

<sup>7</sup> Shaub, H., "A History of ASTM Accomplishments in Low Temperature Engine Oil Rheology," *Symposium on Low Temperature Lubricant Rheology Measurement and Relevance to Engine Operation*, ASTM STP 1143, Rhodes, R. B., ed., ASTM, 1992, pp. 1–19.

motion, temperature scanning, and so forth) can lead to differences in the measured apparent viscosity among these test methods with some test oils, particularly when other rheological factors associated with gelation are present. In addition, the three methods differ considerably in cooling rates.

**5.3 Gelation Index and Gelation Index Temperature**—This test method has been further developed to yield parameters called the Gelation Index and Gelation Index temperature. The first parameter is a measure of the maximum rate of torque increase caused by the rheological response of the oil as the oil is cooled slowly. The second parameter is the temperature at which the Gelation Index occurs.

## 6. Apparatus<sup>3</sup>

6.1 Test Cell, shown in Fig. 1, consisting of a matched rotor and a stator of the following critical dimensions:

6.1.1 Rotor dimensions for: critical length is 65.5 mm ( $\pm 0.1$  mm) and critical diameter is 18.40 mm ( $\pm 0.02$  mm).

6.1.2 Stator dimensions for: critical diameter is 22.05 mm ( $\pm 0.02$  mm) at whatever length will satisfy the immersion depth when the upper oil level is a minimum of 15 mm below the cooling liquid level over the entire temperature range.

6.2 *Viscometer Drive Modules*, rotational viscometer drive modules capable of producing an analog signal to an analog-to-digital converter or other analog signal data processor such as a strip-chart recorder.

6.2.1 With the rotor and stator described in 6.1.1 and 6.1.2, the viscometer drive module shall be capable of measuring to at least 45 000 mPa·s (cP).

6.3 *Test Cell Alignment Device*, simultaneously maintains a vertical axial alignment and reasonably consistent positioning of the rotor in the stator to give repeatable torque readout from test to test when setting up the apparatus for analysis.

6.3.1 *Viscometer Support*, supports the viscometer drive module and aligns it vertically.

6.3.2 *Stator Collar*—clamps the stator and supports it when the stator collar is attached to the viscometer support.

6.4 A means of providing a dry gas atmosphere over the top of the test sample is necessary to prevent condensation and freezing of water on the oil surface.

6.5 *Programmable Liquid or Scanning Brookfield Technique (SBT) Direct Cool Bath*, capable of running either the calibration or the testing program with temperature control of  $\pm 0.1$  °C over the temperature range desired at 1 °C/h.

6.5.1 *Temperature Controller*, is set up to operate according to two programs, the Calibration program and the test program. At any temperature the controller modulates temperature within 0.1 °C of the desired value.

6.6 *Computer, Analog-to-Digital Converter, and Analysis Program*, means of receiving data from the viscometer drive module and converting this data into the desired information.

6.7 *Sample Preheater*—A programmable water bath, air bath or oven, or dry bath (integrated or separate) for precise control of the test oils at 90 °C  $\pm$  2 °C during immersion time after the sample reaches pre-treatment temperature. SBT Direct Cool bath can also perform the preheating portion of the test.

6.8 *Thermometer*—Calibrated liquid-in-glass or digital contact thermometer meeting the following requirements:

6.8.1 *Calibrated Liquid-in-Glass Thermometer*—One calibrated at 90 °C and reading to  $\pm 0.2$  °C and another calibrated at  $-20$  °C reading to  $\pm 0.1$  °C.

6.8.2 *Digital Contact Thermometer*—A DCT meeting the criteria of Table 1.

## 7. Materials<sup>3</sup>

7.1 *Calibration Oil*, a Newtonian calibration oil of specified dynamic viscosity and viscosity index over a temperature range of  $-5$  °C to  $-35$  °C.

7.2 *Gelation Index Reference Oils, GIR-Series, Non-Newtonian Reference Oils*, having Gelation Indices of established values as well as related values for the Gelation Index temperatures.

7.3 *Finger Cots*, latex, used to close the top of the oil-filled stators when they are in the sample preheater and subject to water condensation inside the stator.

## 8. Sampling

8.1 Approximately a 20 mL sample of test oil is necessary for the test.

## 9. Preparation of the Apparatus

9.1 Pretreat the samples using a preheater.

9.1.1 *Water Baths*—Using boiling distilled water and correcting for barometric pressure (if significant because of altitude of the laboratory), check the calibration of the liquid-in-glass or digital contact thermometer for 90 °C used in the sample preheater by appropriate methods.

9.1.1.1 Check that the water bath is filled with distilled water to a level 20 mm above the oil level in the immersed stators and that the sample preheater temperature is 90 °C  $\pm$  2 °C. Complete this check upon initial set-up or if test results indicate suspicious



**TABLE 1 Digital Contact Thermometer Criteria for the Independent Temperature Indicator**

Parameter	Liquid Baths	Dry Baths
Nominal temperature range <sup>A</sup>		–40 °C to 0 °C
Display resolution, minimum		0.1 °C
Accuracy, <sup>B</sup> minimum		–40 °C to 0 °C: ±100 mK (±0.1 °C)
Sensor type		PRT
Immersion depth <sup>C</sup>	114 mm (4.50 in.) minimum by Practice <b>D7962</b>	89 mm (3.50 in.) minimum by Practice <b>D7962</b>
Measurement drift <sup>D</sup>		less than 100 mK (0.1 °C) per year
Response time <sup>E</sup>		12 s
Sensor sheath, <sup>F</sup> max diameter	4.77 mm (0.188 in.)	3.18 mm (0.125 in.)
Sensor length, <sup>G</sup> max		25 mm (1.0 in.)
Temperature calibration data <sup>H</sup>	When the ‘range-of-use’ is 30° or greater and less than 90° then at least 3 data points are required. When the ‘range-of-use’ is 90° or greater, then at least 4 data points are required. In all cases the calibration data is to be included in calibration report.	
Temperature calibration report	The DCT shall have a report of temperature calibration traceable to a national calibration or metrology standards body issued by a competent calibration laboratory with demonstrated competency in temperature calibration. An ISO 17025 accredited laboratory with temperature calibration in its accreditation scope would meet this requirement.	

<sup>A</sup> A device’s minimum and maximum temperature may be different than the values shown provided the calibration requirements are met.

<sup>B</sup> Accuracy is the total combined accuracy of the DCT unit, which includes the display, electronics, and sensor probe with correction factors.

<sup>C</sup> Minimum probe immersion depth as determined by Practice **D7962**, or an equivalent procedure, and is to be equal to or less than the value in the table. This is the minimum immersion needed to obtain an accurate temperature measurement. Thus, the actual immersion will likely exceed this minimum.

<sup>D</sup> Drift is the difference between the corrected DCT temperature and a reference.

<sup>E</sup> *Response Time*—This applies to a Digital Contact Thermometer’s (DCT) combined display and sensor system. Conformance with this requirement is to be provided in the manufacturer’s or supplier’s product documentation. Response time is defined as the time for a DCT to respond to a 63.2 % step change in temperature. The step change begins with the DCT probe at an initial temperature of 20 °C ± 5 °C in air and the timing begins when it is transferred to water at 77 °C ± 5 °C which is flowing at 0.9 m/s ± 0.09 m/s past the sensor, as described in Test Method **E644** or an equivalent method. The DCT display refresh rate is to be at intervals of every 3 seconds or less.

<sup>F</sup> Sensor sheath is the tube that holds the sensing element. The value is the nominal outside diameter of the sheath segment containing the sensing element.

<sup>G</sup> The physical length of the temperature sensing element. Contact the DCT supplier to determine whether this parameter is met, as it will not be accessible to the user.

<sup>H</sup> Minimum number of calibration data points used to establish calibration.

viscous behavior of the sample. Examples of such behavior might include non-repeatable Gelation Indices or GI temperature for a given fluid, unexpectedly high or low Gelation Indices, gelation at an unexpected temperature, or non-repeatable viscosity-temperature curves.

9.1.2 *Air Baths or Ovens and Separate Dry-block Heaters*—Check the calibration of the temperature sensing device by appropriate methods. The temperature should be constant at 90 °C ± 2 °C. Complete this check upon initial set-up or if test results indicate suspicious viscous behavior of the sample. Examples of such behavior might include non-repeatable Gelation Indices or GI temperature for a given fluid, unexpectedly high or low Gelation Indices, gelation at an unexpected temperature, or non-repeatable viscosity-temperature curves.

9.1.2.1 Determine the length of time required to bring the sample up to 90 °C. Use this time interval to establish the length of time the sample is held in the preheater.

NOTE 2—Preheaters integral to the dry block bath and calibrated at –20 °C can reasonably be assumed to hold 90 °C ± 2 °C without additional checks.

9.2 *Preparing Programmable Cooling Bath*—If using a liquid bath, fill to proper depth according to supplier’s instructions at –5 °C.

NOTE 3—To ensure adequate cooling fluid height above the sample, it is advisable to fill the liquid bath at –5 °C to the appropriate level indicated by the manufacturer in the owner’s manual to avoid over-filling the bath and to always bring the bath back to this temperature when on stand-by. This slows the evaporation rate. In addition, for many liquid baths, operation at some temperature moderately below room temperature maintains best operational response. Finally, it prevents overflow of the bath medium due to expansion of the cooling fluid. Cooling fluid must not be added to the bath during a sample test or calibration to avoid temperature deviations.

9.2.1 Install or check the cooling programs for the programmable cooling bath. The programs to be implemented are shown in **Tables 2 and 3**. **Table 2** is for the calibration of a cooling rate of 2 °C per hour. **Table 3** is the sample profile with a cooling rate

**TABLE 2 Program for Programmable Cooling Bath to Obtain Calibration Information—Calibration Profile**

Step	Action	°C	Time
1	Cool to –5 °C and hold	–5	<sup>A</sup>
2	Stabilize bath at –5 °C	–5	<sup>A</sup>
3	Set up data acquisition and initiate program	–5	<sup>A</sup>
4	Cool to –40 °C or until 40 000 cP is reached	–5 to –40	1 °C/h or 2 °C/h <sup>B</sup>
5	Return to –5 °C and hold	–5	<sup>A</sup>

<sup>A</sup> Indeterminate, non-critical period.

<sup>B</sup> See **Note 7** in **11.1.3**.

**TABLE 3 Program for Programmable Cooling Bath to Obtain Information on Test Oils**

Step	Action	°C	Time
1	Cool to -5 °C and hold	-5	A
2	Stabilize bath at -5 °C	-5	A
3	Set up data acquisition and initiate program	-5	A
4	Cool to -40 °C or until 40 000 cP is reached	-5 to -40	1°C/h
5	Return to -5 °C and hold	-5	A

<sup>A</sup> Indeterminate, non-critical period.

of 1 °C per hour.

9.3 Check to see that the upper hook threaded (left hand thread) to the viscometer drive module's driveshaft is firmly finger-tightened. In the tightening process gently and slightly *lift* the driveshaft.

NOTE 4—Do *not* pull down or push or pull laterally on the driveshaft as this may harm the internal jeweled bearing and perhaps bend the driveshaft as well.

## 10. Calibration of the Programmable Cooling Bath and Preparation for Calibration of the Test Cell

10.1 Using the programmable cooling bath temperature controller and manufacturer's instructions, temporarily set bath temperature at -20 °C and allow to come to equilibrium for 1 h. For the dry block bath, fill the test cells with 40 mL of methanol and place a rubber stopper on the cells. Check liquid bath temperature, or cell temperature for the dry block bath, using an independent, accurate and sensitive temperature indicator such as a short-range, partial-immersion thermometer or a digital contact thermometer (DCT) that meets the criteria in **Table 1**. If using a DCT with the liquid bath, insert the DCT so the tip of the probe is between 115 mm and 120 mm below the surface of the bath fluid. If using a DCT with the dry block bath, insert the DCT so the tip of the probe is between 90 mm and 95 mm from the surface of the methanol in the test cell. If the independent temperature indicator shows that the measured temperature is more than  $\pm 0.2$  °C from set point on the programmable cooling bath or the temperature indicator integral to the temperature controller, or both, either the controller requires adjustment, or the temperature indicator integral to the controller is out of calibration, or both. Follow the manufacturer's instructions for the programmable cooling bath to mitigate the situation.

10.1.1 Perform the steps described in **10.1** at least every 6 months.

NOTE 5—Any time following the procedure of **10.1** reveals a difference in temperature between the independent temperature indicator and the programmable cooling bath set point, after the situation has been mitigated it is recommended to calibrate the test cell by following the steps of Section **11**.

10.2 Turn the programmable cooling bath on to control at -5 °C.

10.3 At room temperature, pour the calibration oil to the fill line (**Fig. 1**) of the stators to be calibrated and place in a suitable rack until ready. For stainless steel stators, insert 16 mL of sample using a volume-measuring device such as a syringe.

NOTE 6—Since the calibration oil is Newtonian in behavior throughout the low temperature test range and thus is non-gelling, no special pre-heating preparation is necessary.

10.4 *Computer Data Acquisition and Analysis*—For setting up a computer automated analysis, refer to the owner's manual or **Appendix X4**.

## 11. Calibration of the Test Cell

11.1 *Computer Method:*

11.1.1 This calibration shall be completed at least one time each year.

11.1.2 Set up cell and viscometer head as directed by the manufacturer using a reference Newtonian oil having an appropriate viscosity range and established as a standard for the test method.

11.1.3 Select special calibration cooling program shown in **Table 2** on programmable cooling bath according to manufacturer's instructions but do not start the program.

NOTE 7—The special cooling program shown in **Table 2** for testing unknown oils may be used for a calibration if the user wishes to run a calibration on one viscometer while running an unknown oil on another viscometer.

11.1.4 Open and enter required viscosity and temperature data in computer program.

11.1.5 Now open main flow control valve for dry gas flow above liquid in stator at approximate rate of 10 mL/min per cell.

11.1.6 Simultaneously initiate:

11.1.6.1 Cooling program on programmable cooling bath, and

11.1.6.2 Data recording on computer according to bath manufacturer's instructions.

11.1.7 Collect and analyze complete recorded data using program developer's instructions.