



Designation: C1294 – 20

Standard Test Method for Compatibility of Insulating Glass Edge Sealants with Liquid-Applied Glazing Materials¹

This standard is issued under the fixed designation C1294; the number immediately following the designation indicates the year of original adoption or, in the case of revision, the year of last revision. A number in parentheses indicates the year of last reapproval. A superscript epsilon (ϵ) indicates an editorial change since the last revision or reapproval.

1. Scope

1.1 This test method covers a laboratory procedure for quantitatively measuring the compatibility of liquid-applied glazing materials with an insulating glass unit edge sealant. Compatibility is determined by measuring the changes in the insulating glass edge sealant adhesive and cohesive properties. Hereinafter insulating glass is referred to as IG.

1.2 This test method does not address the issue of the integrity of the hermetic seal or changes to the vision area in an IG unit. Such factors as possible unit fogging or primary sealant reaction in a dual-seal system due to volatile components permeating the IG sealant are not considered in this test method.

1.3 The committee with jurisdiction over this standard is not aware of any comparable standards published by other organizations.

1.4 *This standard does not purport to address all of the safety concerns, if any, associated with its use. It is the responsibility of the user of this standard to establish appropriate safety, health, and environmental practices and determine the applicability of regulatory limitations prior to use.*

1.5 *This international standard was developed in accordance with internationally recognized principles on standardization established in the Decision on Principles for the Development of International Standards, Guides and Recommendations issued by the World Trade Organization Technical Barriers to Trade (TBT) Committee.*

2. Referenced Documents

2.1 *ASTM Standards:*²

C717 Terminology of Building Seals and Sealants

¹ This test method is under the jurisdiction of ASTM Committee C24 on Building Seals and Sealants and is the direct responsibility of Subcommittee C24.20 on General Test Methods.

Current edition approved May 1, 2020. Published June 2020. Originally approved in 1995. Last previous edition approved in 2015 as C1294–15. DOI: 10.1520/C1294-20.

² For referenced ASTM standards, visit the ASTM website, www.astm.org, or contact ASTM Customer Service at service@astm.org. For *Annual Book of ASTM Standards* volume information, refer to the standard's Document Summary page on the ASTM website.

C1265 Test Method for Determining the Tensile Properties of an Insulating Glass Edge Seal for Structural Glazing Applications

3. Terminology

3.1 *Definitions*—Refer to Terminology C717 for definitions of the following terms: adhesive failure, cohesive failure, compatibility, compound, elongation, glazing, seal, sealant, standard conditions, and substrate.

4. Summary of Test Method

4.1 This test method includes the measurement of tensile force, elongation, and percent cohesive or adhesive failure and observations of the specimen's general physical appearance and observation of elongation.

4.2 Test specimens are exposed to 70°C (158°F) heat for four weeks while contacting the liquid-applied glazing material being evaluated.

4.2.1 Control specimens are exposed only to the 70°C (158°F) heat.

4.3 Compatibility is determined by comparing the measured and observed properties of the test specimens to the control samples.

5. Significance and Use

5.1 Liquid-applied glazing materials, bedding sealants, glazing compounds (that is, glazing sealants) are designed to provide a seal between the IG unit and the window or wall framing. Frequently there is physical contact between these materials and an IG unit edge sealant. Depending on the particular IG unit edge sealant, there can be a detrimental physical or chemical interaction between it and the liquid-applied glazing material. Detrimental effects may include: weakening, softening, hardening, or adhesive failure of the IG edge sealant, or visual obstruction inside the IG unit.

6. Apparatus and Accessory Materials

6.1 *Oven*, forced draft, capable of maintaining a constant temperature of $70 \pm 3^\circ\text{C}$ ($158 \pm 5^\circ\text{F}$).

6.2 *Tensile Testing Machine*, capable of producing a tensile load on the specimen at the rate of 5 ± 0.51 mm (0.2 ± 0.02 in.) per minute.

6.2.1 *Fixed Member*—A fixed or essentially stationary member carrying one grip.

6.2.2 *Moveable Member*—A moveable member carrying a second grip.

6.2.3 *Grips*—The grips should be suitable to firmly grasp the test fixture that holds the test specimen and should be designed to eliminate eccentric specimen loading. Specimen loading should be parallel to the centerline of the short axis of the sealant. A swivel or universal joint near each end of the specimen should be provided for alignment purposes.

6.2.4 *Grip Fixture*—A fixture capable of being held by the grips and furnishing a tensile force to and maintaining proper alignment with the test specimen.

6.3 *Spatulas*, for use in mixing and applying sealant.

6.4 *Paper Cup or Can*, for use in mixing multicomponent sealants when applicable.

6.5 *Plastic Cartridge*, (Semco), to extrude sealant when applicable.

6.6 *Triple-Beam or Electronic Balance*, accurate to ± 0.01 g (3.5 by 10^{-4} oz) for weighing multicomponent sealant mixes and finished test specimens.

6.7 *Glass Substrates*, clear float glass, 6 by 25 by 75 mm (0.25 by 1 by 3 in.). A total of ten substrates is required for each glazing material tested.

6.8 *Spacer*, nominally 13 mm (0.50 in.) wide IG, aluminum spacer with preferably an anodized aluminum surface. Spacers should be cut into 50-mm (2-in.) lengths.

6.9 *Test Fixture* (Fig. 1) to hold the specimen components in place while the IG sealant is applied and cured.

6.10 *Aluminum Foil*, standard kitchen wrapping foil is suitable.

6.11 *Container*, a shallow aluminum or glass pan or tray is suitable. The container must be large enough to hold all the test specimens. A container is required for each combination of IG edge sealant and liquid-applied glazing material compound being tested.

7. Specimen Preparation

7.1 Prepare a set of five test specimen assemblies for each IG edge sealant or liquid-applied glazing material, or both, being tested.

7.2 Construction of the test specimens is done by placing the 13 by 50-mm (0.50 by 2-in.) IG spacers into the recesses in the test fixture. The glass substrates are installed on either side of the spacer and the assembly is clamped together with machine screws through the ends of the side bars. The test fixture holds the samples stationary while the IG edge sealant is applied. The IG edge sealant siteline should be approximately 6 mm (0.25 in.) after the specimen is prepared.

7.3 Take special care to strike off the sealant flush with the glass substrates.

7.4 Cure the test specimens for a total of 7 days at standard conditions.

7.5 The samples should be removed from the test fixture after the end of the first day of the seven-day cure period.

7.6 Measure the width and length of the sealant contact area in millimetres (inches) with the glass substrates for use in calculating the tensile strength of the assembly per unit area.

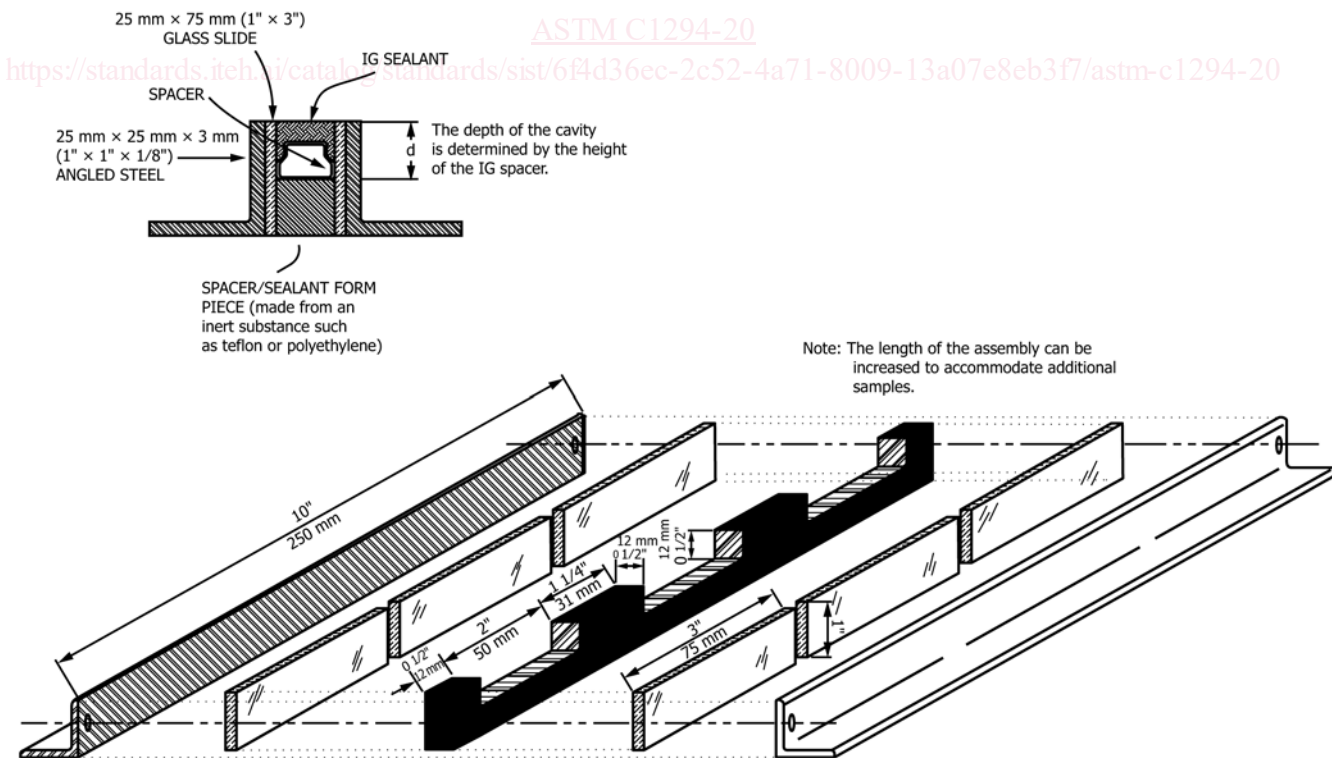

FIG. 1 Sample Assembly IG Compatibility Test

8. Procedure

8.1 Spread the liquid-applied glazing material onto the bottom of the aluminum or glass pan to a thickness of approximately 6 mm (0.25 in.).

8.2 Press sealed edges of three of the IG edge specimens into the liquid-applied glazing material to a depth of approximately 1.6 mm (0.0625 in.).

8.3 Cover the container with aluminum foil and place in the oven for four weeks at $70 \pm 2^\circ\text{C}$ (158°F).

8.4 Place the remaining two control specimens into another foil-covered container with no liquid-applied glazing material and place in the oven for four weeks at $70 \pm 2^\circ\text{C}$ ($158 \pm 3^\circ\text{F}$). One set of control specimens are sufficient for each IG edge sealant when more than one liquid-applied glazing material is being tested. Do not expose more than one IG edge sealant control or one type of liquid-applied glazing material in a single container.

8.5 After four weeks in the oven, remove the containers from the oven and condition at standard conditions for a minimum of 1 h and a maximum of 24 h.

8.6 Following the conditioning, remove the aluminum foil from the top of the pan. Carefully trim the liquid-applied glazing material from the outside face of the three test specimens. Take care not to disturb the IG edge sealant.

8.7 Further condition the specimens for a minimum of 1 h but not more than 4 h at standard conditions.

8.8 After completion of conditioning, observe the test specimens for discoloration, softening, tackiness, adhesive and cohesive failure, swelling, cracking, or any other observed difference in the IG edge sealant specimens from the control specimens.

8.9 After observation, pull each specimen on a tensile test machine at a rate of 5 mm (0.2 in.) per minute. Record the tensile load in newtons (pounds-force) of the PIB peak, the elongation in millimetres (inches) at PIB peak and maximum elongation in millimetres (inches) at failure. Determine the percent of adhesive and cohesive failure. Refer to Test Method **C1265** to view a typical stress strain graph of this procedure.

9. Report

9.1 Observations and test results are reported on the form shown in **Fig. 2**.

9.2 Report the following information:

9.2.1 Any variation from the test method (for instance, a change in curing or conditioning cycles).

9.2.2 The actual IG edge sealant minimum contact area, in mm^2 (in.^2).

9.2.3 Tensile force at the PIB peak and at ultimate failure, in N (lbf).

9.2.4 Calculate the tensile stress in pascals (lbf/in^2) at failure.

9.2.5 Elongation in millimetres (inches) of movement at PIB peak and at failure. Percent elongation cannot be calculated due to variable sealant thickness in each specimen. Elongation for this test method is total sample movement prior to failure.

9.2.6 The mode of failure in percent cohesive/adhesive failure on each substrate.

9.2.7 Any observation from **8.8**.

10. Precision and Bias³

10.1 A statistical analysis made from the results obtained from a round-robin test of the tensile properties in which each of four laboratories tested two glazing sealants and two IG edge sealants in accordance with the prescribed test for the effect of the glazing sealant on the edge sealant resulted in the following:

10.1.1 The repeatability (within a given laboratory) interval for two materials tested by four laboratories is 34.63 N (7.79 lb). In future use of this test method, the difference between two test results obtained in the same laboratory on the same material will be expected to exceed 34.63 N only about 5 % of the time.

10.1.2 The reproducibility (between given laboratories) two materials tested by four laboratories is 103.9 N (23.4 lb). In future use of this test method, the difference between two test results obtained in a different laboratory on the same material will be expected to exceed 103.9 N only about 5 % of the time.

11. Keywords

11.1 bedding sealant; compatibility; glazing sealant; insulating glass; sealant

³ Supporting data have been filed at ASTM International Headquarters and may be obtained by requesting Research Report RR:D24-1049