



Designation: **F2178 – 17b F2178/F2178M – 20**

Standard Test Method Specification for Determining the Arc Rating and Standard Specification for Arc Rated Eye or Face Protective Products¹

This standard is issued under the fixed designation **F2178/F2178M**; the number immediately following the designation indicates the year of original adoption or, in the case of revision, the year of last revision. A number in parentheses indicates the year of last reappraisal. A superscript epsilon (ϵ) indicates an editorial change since the last revision or reappraisal.

1. Scope

1.1 This test method and product specification is used to measure the arc rating and specify the requirements for products intended for use as eye or face protection for workers exposed to electric arcs that would generate heat flux values from 84 to 25 120 kW/m² [2 to 600 cal/cm²s]. Products are tested as sold.

1.2 This test method determines an arc rating for eye or face protective products. The faceshield, safety spectacle, goggle or other applicable portions of the complete product must meet ANSI Z87.1. This excludes the textile or non ANSI Z87.1 testable parts of the hood assemblies or other tested products. This standard does not measure optical and impact properties (see ANSI Z87.1) but does specify requirements for optical and impact properties.

1.3 The materials covered by this standard are in the form of faceshields attached to the head by protective helmets (hard hats), headgear, hood assemblies, safety spectacles or goggles. Faceshields, safety spectacles or goggles are tested with or without other face and head protective products, for example, sock hoods, balaclavas, sweat shirt hoods or jacket hoods.

1.3.1 Fabric layers used in the design of face protection products such as in hood, neck guards, balaclava, shall meet the requirements of Specification **F1506**. When fabrics are designed into the protection provided for eye or face protective products, the arc rating of fabric system shall be determined first by Test Method **F1959/F1959M**.

1.3.2 The arc rating of the eye or face protective product which requires fabric to provide protection to the face or head will not be higher than the lower arc rating of either the fabric system or the shield/visor assembly.

1.4 This test method shall be used to measure and describe the properties of materials, products, or assemblies in response to convective and radiant energy generated by an electric arc under controlled laboratory conditions and does not purport to predict damage from light other than the thermal aspects measured.

1.5 The values stated in SI units shall be regarded as standard except as noted. Within the text, alternate units are shown in brackets. The values stated in each system may not be exact equivalents; therefore, alternate systems must be used independently of the other. Combining values from the systems described in the text may result in nonconformance with the method.

1.6 This standard does not purport to describe or appraise the effect of the electric arc fragmentation explosion and subsequent molten metal splatter, which involves the pressure wave containing molten metals and possible fragments of other materials except to the extent that heat energy transmission due to these arc explosion phenomena is reduced by test specimens.

1.7 *This standard shall not be used to describe or appraise the fire hazard or fire risk of materials, products, or assemblies under actual fire conditions. However, results of this test may be used as elements of a fire assessment which takes into account all of the factors which are pertinent to an assessment of the fire hazard of a particular end use.*

1.8 *This standard does not purport to address all of the safety concerns, if any, associated with its use. It is the responsibility of the user of this standard to establish appropriate safety, health, and environmental practices and determine the applicability of regulatory limitations prior to use. For specific precautions, see Section 7.*

1.9 *This international standard was developed in accordance with internationally recognized principles on standardization established in the Decision on Principles for the Development of International Standards, Guides and Recommendations issued by the World Trade Organization Technical Barriers to Trade (TBT) Committee.*

¹ This test method specification is under the jurisdiction of ASTM Committee **F18** on Electrical Protective Equipment for Workers and is the direct responsibility of Subcommittee **F18.65** on Wearing Apparel.

Current edition approved Oct. 1, 2017/April 1, 2020. Published November 2017/June 2020. Originally approved in 2002. Last previous edition approved in 2017 as **F2178 – 17a/F2178 – 17b**. DOI: 10.1520/F2178-17B:10.1520/F2178_F2178M-20.

2. Referenced Documents

2.1 ~~ASTM Standards:~~²

~~C177 Test Method for Steady-State Heat Flux Measurements and Thermal Transmission Properties by Means of the Guarded-Hot-Plate Apparatus~~

~~D123 Terminology Relating to Textiles~~

~~D3776 Test Methods for Mass Per Unit Area (Weight) of Fabric~~

~~D4391 Terminology Relating to The Burning Behavior of Textiles~~

~~E457 Test Method for Measuring Heat-Transfer Rate Using a Thermal Capacitance (Slug) Calorimeter~~

~~F1494 Terminology Relating to Protective Clothing~~

~~F1506 Performance Specification for Flame Resistant and Electric Arc Rated Protective Clothing Worn by Workers Exposed to Flames and Electric Arcs~~

~~F1958/F1958M Test Method for Determining the Ignitability of Non-flame-Resistant Materials for Clothing by Electric Arc Exposure Method Using Mannequins~~

~~F1959/F1959M Test Method for Determining the Arc Rating of Materials for Clothing~~

2.2 ~~ANSI/IEEE Standards:~~

~~IEEE Standard Dictionary of Electrical and Electronics Terms~~³

~~ANSI Z87.1-2003 Practice for Occupational and Educational Eye and Face Protection~~⁴

3. Terminology

3.1 *Definitions*—For definitions of other textile terms used in this method, refer to terminology in Terminology ~~D123, D4391, F1494~~ and the IEEE Standard Dictionary of Electrical and Electronics Terms.

3.2 *Definitions of Terms Specific to This Standard:*

3.2.1 *afterflame, n*—persistent flaming of a material after the ignition source has been removed.

3.2.2 *afterflame time, n*—the length of time for which a material continues to flame after the ignition source has been removed.

3.2.3 *arc duration, n*—time duration of the arc, s.

3.2.4 *arc energy, vi dt, n*—sum of the instantaneous arc voltage values multiplied by the instantaneous arc current values multiplied by the incremental time values during the arc, J.

3.2.5 *arc gap, n*—distance between the arc electrodes, cm [in.].

3.2.6 *arc rating, n*—value attributed to materials that describes their performance to exposure to an electric arc discharge, J/cm² (cal/cm²).

3.2.6.1 *Discussion*—

The arc rating is expressed in J/cm² (cal/cm²) and is derived from the determined value of *ATPV* or *E_{BT}* (should a material system exhibit a breakopen response below the ATPV value):

3.2.7 *arc thermal performance value (ATPV), n*—the incident energy of a fabric or material that results in 50 % probability that sufficient heat transfer through the specimen is predicted to cause the onset of a second-degree skin burn injury based on the Stoll curve, kW/m² [cal/cm²].⁵

3.2.8 *arc voltage, n*—voltage across the gap caused by the current flowing through the resistance created by the arc gap (V).

3.2.9 *asymmetrical arc current, n*—the total arc current produced during closure; it includes a direct component and a symmetrical component, A.

3.2.10 *blowout, n*—the extinguishing of the arc caused by a magnetic field.

3.2.11 *breakopen, n*—*in electric arc testing*, a material response evidenced by the formation of one or more holes in the material which may allow thermal energy to pass through material.

3.2.11.1 *Discussion*—

² For referenced ASTM standards, visit the ASTM website, www.astm.org, or contact ASTM Customer Service at service@astm.org. For *Annual Book of ASTM Standards* volume information, refer to the standard's Document Summary page on the ASTM website.

³ Available from Institute of Electrical and Electronics Engineers, Inc. (IEEE), 445 Hoes Ln., P.O. Box 1331, Piscataway, NJ 08854-1331, 08854-4141, <http://www.ieee.org>.

⁵ Derived from Stoll, A. M., and Chianta, M. A., "Method and Rating System for Evaluations of Thermal Protection," *Aerospace Medicine*, Vol 40, 1969, pp. 1232-1238 and Stoll, A. M., and Chianta, M. A., "Heat Transfer through Fabrics as Related to Thermal Injury," *Transactions—New York Academy of Sciences*, Vol 33 (7), Nov. 1971, pp. 649-670. Derived from Stoll, A. M., and Chianta, M. A., "Method and Rating System for Evaluations of Thermal Protection," *Aerospace Medicine*, Vol 40, 1969, pp. 1232-1238 and Stoll, A. M., and Chianta, M. A., "Heat Transfer through Fabrics as Related to Thermal Injury," *Transactions—New York Academy of Sciences*, Vol 33(7), Nov. 1971, pp. 649-670.

The specimen is considered to exhibit breakopen when any hole in the material or fabric is at least 1.6 cm² [0.5 in.²] in area or at least 2.5 cm [1.0 in.] in any dimension. For textile materials, single threads across the opening or hole do not reduce the size of the hole for the purposes of this test method. In multiple layer specimens, if some of the layers are ignitable, breakopen occurs when these layers are exposed.

3.2.12 *breakopen threshold energy (E_{BT})*, n —the incident energy on a fabric or material that results in a 50 % probability of breakopen.

3.2.12.1 *Discussion*—

This is the value in J/cm² [cal/cm²] determined by use of logistic regression analysis representing the energy at which breakopen of the layer occurred.

3.2.13 *deformation*, n —for electric arc testing of eye or face protective products, the sagging of material greater than 7.6 cm [3 in.] or melting in any manner that the faceshield/window touches any part of the body.

3.2.14 *dripping*, n —in electric arc testing, a material response evidenced by flowing of a specimen's material of composition.

3.2.14.1 *Discussion*—

Dripping is exhibited by either the fabric material or faceshield material, or other parts of eye or face protective products.

3.2.15 *electric arc ignition*, n —in electric arc testing of eye or face protective products, the initiation of combustion as related to electric arc exposure, a response that causes the ignition of textile test specimen material which is accompanied by heat and light, and then subsequent burning for at least 5 s, and consumption of at least 25 % of the test specimen area.

3.2.15.1 *Discussion*—

For multilayer specimens, consumption of the innermost FR layer must be at least 25 %.

3.2.16 *faceshield*, n —a protective device commonly intended to shield the wearer's face, or portions thereof, in addition to the eyes, from certain hazards.

3.2.17 *heat flux*, n —the thermal intensity indicated by the amount of energy transmitted per area and time W/m² [cal/cm²s].

3.2.18 *i^2t* , n —sum of the instantaneous arc current values squared multiplied by the incremental time values during the arc, A²/s.

3.2.19 *incident energy monitoring sensors*, n —sensors mounted on each side of each head, using calorimeters, not covered by specimens, used to measure incident energy.

3.2.20 *incident exposure energy (E_i)*, n —in arc testing, the total incident energy delivered to monitor calorimeter sensors as a result of the arc exposure, J/cm² [cal/cm²].

3.2.20.1 *Discussion*—

In an arc test exposure, incident exposure energy for a specimen is determined from the average of the measured incident energy from the respective two monitor sensors adjacent to the test specimen.

3.2.21 *material response*, n —material response to an electric arc is indicated by the following terms: breakopen, melting, dripping, deformation, afterflame time, shrinkage, and electric arc ignition.

3.2.22 *melting*, n —in arc testing, a material response evidenced by softening of the material.

3.2.23 *peak arc current*, n —maximum value of the AC arc current, A.

3.2.24 *RMS arc current*, n —root mean square of the AC arc current, A.

3.2.25 *shrinkage*, n —in testing eye or face protective products, a material response evidenced by reduction in specimen size.

3.2.26 *Stoll curve*, n —an empirical predicted second-degree skin burn injury model, also commonly referred to as the *Stoll Response*.

3.2.27 *X/R ratio*, n —the ratio of system inductive reactance to resistance. It is proportional to the L/R ratio of time constant, and is, therefore, indicative of the rate of decay of any DC offset. A large X/R ratio corresponds to a large time constant and a slow rate of decay.

4. Summary of Test Method

4.1 This test method determines the heat transport response across a material, fabric, or fabric system when exposed to the heat energy from an electric arc. This heat transport response is assessed versus the Stoll curve, an approximate human tissue tolerance predictive model that projects the onset of a second-degree burn injury.

4.1.1 Products are mounted on the standard mannequin head containing copper slug calorimeters inserted in the eyes, mouth, and chin positions. During this procedure, the amount of heat energy transferred by the specimen eye or face protective products is measured during and after exposure to an electric arc.

4.1.2 The thermal energy exposure and heat transport response of the test specimen(s) are measured with copper slug calorimeters. The change in temperature versus time is used, along with the known thermo-physical properties of copper to determine the respective thermal energies delivered to and through the specimen(s).

4.2 This procedure incorporates incident energy monitoring sensors.

4.3 Product and material performance for this procedure are determined by comparing the amount of thermal energy generated by the arc flash on monitor sensors with the energy transferred by or through the test specimen(s) and measured by sensors on the mannequin head.

4.4 Product and material responses shall be further described by recording the observed effects of the electric arc exposure on the specimens using the terms in the Report section.

5. Significance and Use

5.1 This test method is intended for the determination of the arc rating of a product/design, intended for use as eye or face protection for workers exposed to electric arcs.

5.1.1 Because of the variability of the arc exposure, different heat transmission values may be observed at individual sensors. The results of each sensor are evaluated in accordance with Section 12.

5.2 This test method maintains the specimen in a static, vertical position and does not involve movement except that resulting from the exposure.

5.3 This test method specifies a standard set of exposure conditions. Different exposure conditions may produce different results.

5.4 This specification covers the minimum performance criteria for arc resistance and other requirements for eye or face protective products used by workers who may be exposed to thermal hazards of momentary electric arcs or flame.

5.5 The purchaser has the option to perform or have performed any of these tests in order to verify the performance of the eye or face protective product. Claims for failure to meet the specification are subject to verification by the manufacturer.

NOTE 1—In addition to the standard set of exposure conditions, other conditions representative of the expected hazard may be used and shall be reported should this data be cited.

6. Apparatus

6.1 *General Arrangement for Determining Rating Using Sensor Heads and Monitor Sensors*—The test apparatus shall consist of supply bus, arc controller, recorder, arc electrodes, two (or optionally three) four-sensor heads, and four (or optionally six) incident energy monitoring sensors. The arc exposure shall be monitored with two incident energy-monitoring sensors for each sensed head.

6.1.1 *Arrangement of the Four-Sensor Heads*—The standard test set up is three four-sensor heads spaced at 120° around the arc (Fig. 1). When one video camera is used to view the testing, it shall be placed so that the front of two of the heads can be viewed. A single head which is viewed from the rear may be removed to facilitate viewing. Each head shall be located vertically to the arc electrodes as shown in Fig. 2. Only calorimetry data from heads that are viewed from the front shall be used (a minimum 50 % view of the facial area is required) to record subjective data during the test. Each four-sensor head shall have two incident energy monitoring sensors. One monitoring sensor shall be positioned on each side of each four-sensor head as shown in Fig. 3.

6.1.2 *Head Construction*—Each four-sensor head and each monitor sensor holder shall be constructed from non-conductive heat resistant material as shown in Fig. 4. Use a mannequin head, size large, made from a non-conductive high temperature resin/fiberglass construction. (A mannequin head, such as Model 7001 D-H, Morgese Soriano or equivalent has been found to be acceptable.) The high-temperature resin used in the construction of the head shall be non-melting and flame resistant. Each four-sensor head and monitoring sensors shall be placed 12 in. (305 mm) from the centerline of the arc electrodes as shown in Fig. 2. Four-sensors shall be mounted in the head as shown in Fig. 4. The mouth sensor shall be forward of the eye sensor plane by 6 mm [$\frac{1}{4}$ in.]. The chin sensor shall be in the horizontal plane (perpendicular to the plane of the eye and mouth) under the chin as shown in Fig. 4. The chin sensor shall protrude below the lowest point of the chin by 3 mm [$\frac{1}{8}$ in.].

6.1.3 Each four-sensor head may be mounted on the mannequin body specified in Test Method F1958/F1958M and the mannequin to simulate a human body. Any clothing on the mannequin (if used) shall be reported.

6.2 The four-sensor head and monitor sensors shall be copper slug calorimeters constructed from electrical grade copper with a single thermocouple wire installed as identified in Fig. 5 (see Test Method E457 for information regarding slug calorimeters).

6.2.1 The exposed surface of the copper slug calorimeters shall be painted with a thin coating of a flat black high temperature spray paint with an emissivity of >0.9 . The painted sensor shall be dried before use and present a uniformly applied coating (no visual thick spots or surface irregularities). Note that an external heat source, for example, an external heat lamp, may be required to completely drive off any remaining organic carriers in a freshly painted surface.

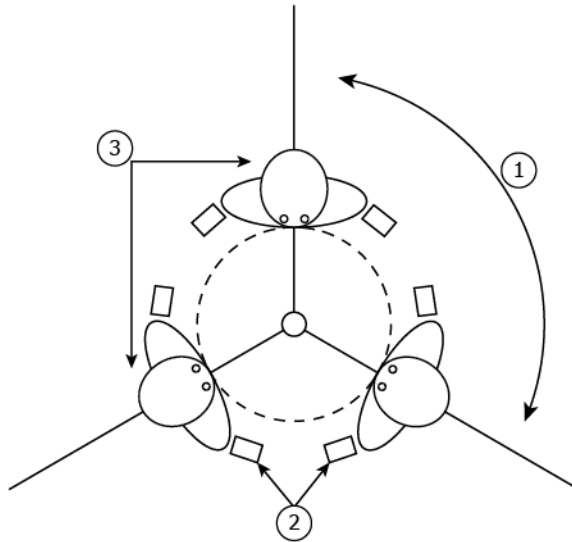

1	120° typical
2	Monitor Sensors (monitor sensors move back for higher energy levels)
3	Four-Sensor Head

FIG. 13 Location of Mannequin Heads

6.2.1.1 *Discussion*—An evaluation of the emissivity of the painted calorimeters used in this test method is available from ASTM; “ASTM Research Program on Electric Arc Test Method Development to Evaluate Protective Clothing Fabric; ASTM F18.65.01 Testing Group Report on Arc Testing Analysis of the F1959/F1959M Standard Test Method—Phase 1.”

6.2.2 The thermocouple wire is installed in the calorimeter as shown in Fig. 5.

6.2.3 Alternate calorimeters are permitted for use as monitor sensors provided they are calibrated and have a similar response to those in 6.2. The use of a different thermocouple junction, exposed surface area, slug material, and mass are allowed and their performance shall be documented in the test results.

6.3 *Sensor Construction*—The sensor mount used to hold the calorimeter shall be constructed from a thermally stable heat resistant material with a minimum thermal conductivity value as indicated in Table 3 (such as Fire-Resistant Structural Insulation or equivalent) and shown in Fig. 5 to prevent unwanted heat conduction. For test exposures above 40 cal/cm² only, existing monitoring sensors may be moved away from the arc center line, perpendicular to the arc, provided they are not blocked. A multiplier shall be determined to give an equivalent exposure value at 30.5 cm [12 in.] (for example, at 45.7 cm [18 in.], the multiplier is 2.25).

6.3.1 For test exposures which create a sensor temperature in excess of 400°C, alternate calorimeters for the monitor sensors shall be used. The alternate sensors shall be calibrated and shall have a similar response. An alternate approach for test exposures which create a sensor temperature in excess of 400°C is to increase the distance between the arc centerline and the monitor sensors from the standard distance of 30.5 cm to 45.7 cm [12 to 18 in.], and to apply a conversion factor to the incident energy measured at a distance of to 45.7 cm [18 in.] in order to approximate the energy at a distance of 30.5 cm [12 in.] In this procedure, the specimen remains at a distance of 30.5 cm [12 in.] from the arc centerline. Copper calorimeter sensor data above 400°C shall be not be valid.

NOTE 2—At an ambient temperature of 25°C, the calorimeter temperature would reach 300°C (ΔT of 275°C) at approximately 36 cal/cm².

6.4 *Supply Bus and Electrodes*—A typical arrangement of the supply bus and arc electrodes is shown in Fig. 2. The arc shall be in a vertical position as shown.

6.4.1 *Electrodes*—Make the electrodes from stainless steel (Alloy Type 303 or Type 304) rod of a nominal 19 mm [0.75 in.] diameter. Lengths of 45.0 cm [18 in.] long initially have been found to be adequate.

6.4.2 *Fuse Wire*—A fuse wire, connecting the ends of opposing electrodes tips, is used to initiate the arc. This wire is consumed during the test; therefore, its mass shall be very small to reduce any effects on the testing. The fuse wire shall be a copper wire with a diameter not greater than 0.5 mm [0.02 in.].

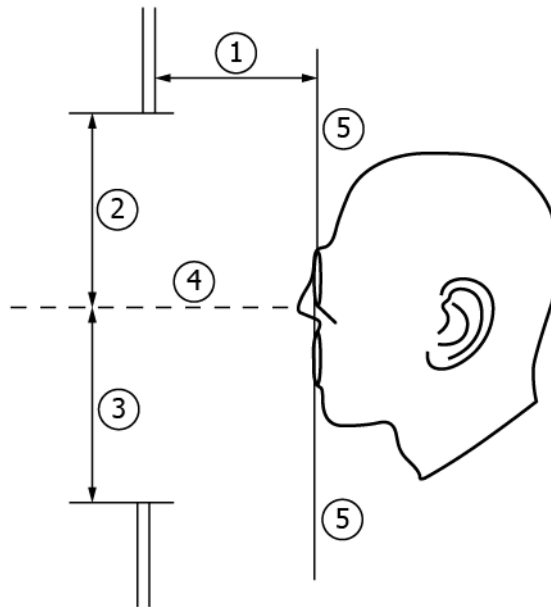

1	Mouth Plane to Electrode Center Line 30.8 cm [12 in.]
2, 3	Center Line to Electrode
4	Center Line
5	Plane of Mouth Sensor and Eye Sensors

FIG. 24 Vertical Location of Heads to Arc Electrodes

6.5 *Electric Supply*—The electric supply should be sufficient to allow for the discharge of an electric arc with a gap of up to 305 mm [12 in.] with alternating arc current from 4000 up to 25 000 amperes, and with arc duration from 3 cycles (0.05 s) up to 90 cycles (1.5 s) (from a 60 Hz supply). The X/R ratio of the test circuit shall be such that the test current contains a DC component resulting in the first peak of the test current having a magnitude of 2.3 times the symmetrical RMS value.

6.6 *Test Circuit Control*—Repeat exposures of the arc currents shall not deviate more than 2 % per test from the selected test level. The make switch shall be capable of point on wave closing within 0.2 cycles from test to test such that the closing angle will produce maximum asymmetrical current with an X/R ratio of the test circuit as stated in 6.5. The arc current, duration, and voltage shall be measured. The arc current, duration, voltage, and energy shall be displayed in graph form and stored in digital format.

6.7 *Data Acquisition System*—The system shall be capable of recording voltage, current, and sufficient calorimeter outputs as required by the test.

6.7.1 The temperature data (calorimeter outputs) shall be acquired at a minimum sampling rate of 20 samples per second per calorimeter. The acquisition system shall be able to record temperatures to 500°C. The temperature acquisition system shall have at least a resolution of 0.1°C and an accuracy of $\pm 0.75^\circ\text{C}$.

6.7.2 The system current and voltage data shall be acquired at a minimum rate of 2000 samples per second. The current and voltage acquisition system shall have at least a resolution of 1 % of the applied voltage and current.

6.8 *Data Acquisition System Protection*—Due to the nature of this type of testing, the use of isolating devices on the calorimeter outputs to protect the acquisition system is recommended.

7. Precautions

7.1 The test apparatus discharges large amounts of energy. In addition, the electric arc produces very intense light. Care shall be taken to protect personnel working in the area. Workers shall be behind protective barriers or at a safe distance to prevent electrocution and contact with molten metal. Workers wishing to directly view the test shall don the appropriate eye protection. If the test is conducted indoors, there shall be a method to ventilate the area to carry away combustion products, smoke, and fumes.

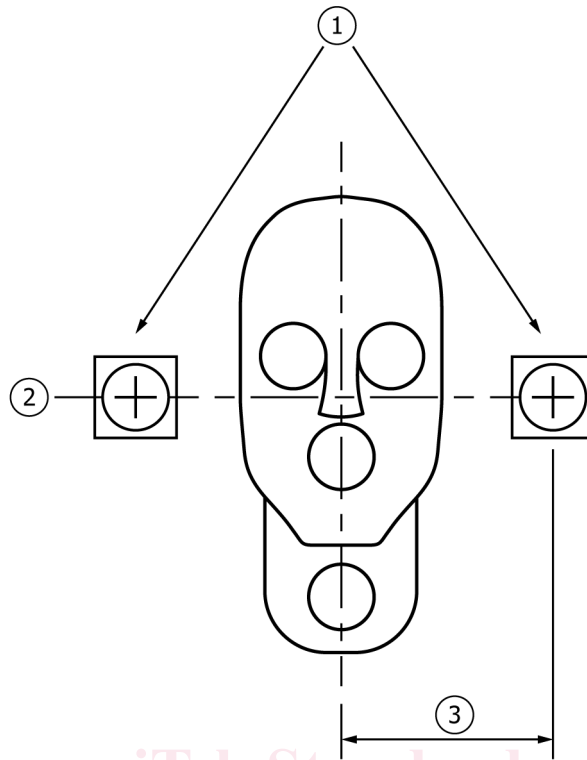

1	Monitor Sensor
2	Center Line
3	Center Line to Monitor
4	Neck Sensor (Optional)

FIG. 35 Mannequin Head with Monitor Sensors

Air currents can disturb the arc reducing the heat flux at the surface of any of the calorimeters. The test apparatus shall be shielded by non-combustible materials suitable for the test area. Outdoor tests shall be conducted in a manner appropriate to prevent exposure of the test specimen to moisture and wind (the elements). The leads to the test apparatus shall be positioned to prevent blowout of the electric arc. The test apparatus shall be insulated from ground for the appropriate test voltage.

7.2 The test apparatus, electrodes, and calorimeter assemblies become hot during testing. Use protective gloves when handling these hot objects.

7.3 Use care when the specimen ignites or releases combustible gases. An appropriate fire extinguisher should be readily available. Ensure the materials are fully extinguished.

7.4 Immediately after each test, the electric supply shall be shut off from the test apparatus and all other lab equipment used to generate the arc, and the apparatus and other lab equipment shall be isolated and grounded. After data acquisition has been completed, appropriate methods shall be used to ventilate the test area before personnel entry. No one shall enter the test area prior to exhausting all smoke and fumes without the appropriate personal protection.

8. Sampling and Specimen Preparation

8.1 Test specimens for four-sensor head test shall be representative of the product, as it will be sold.

8.2 Test specimens shall be mounted as they are normally intended to be worn. If the position of the product is adjustable (such as faceshields with adjustable headgear), tests shall be done in the fully out position for the arc rating so that the ignition level would be evaluated. The actual distance of the shield/visor to the centerline of the electrode shall be measured and reported.

8.3 The thickness of the protective lens material shall be measured with accuracy of 0.01 mm.

8.4 Laundering of the fabric material for hoods and balaclavas is not required prior to testing.

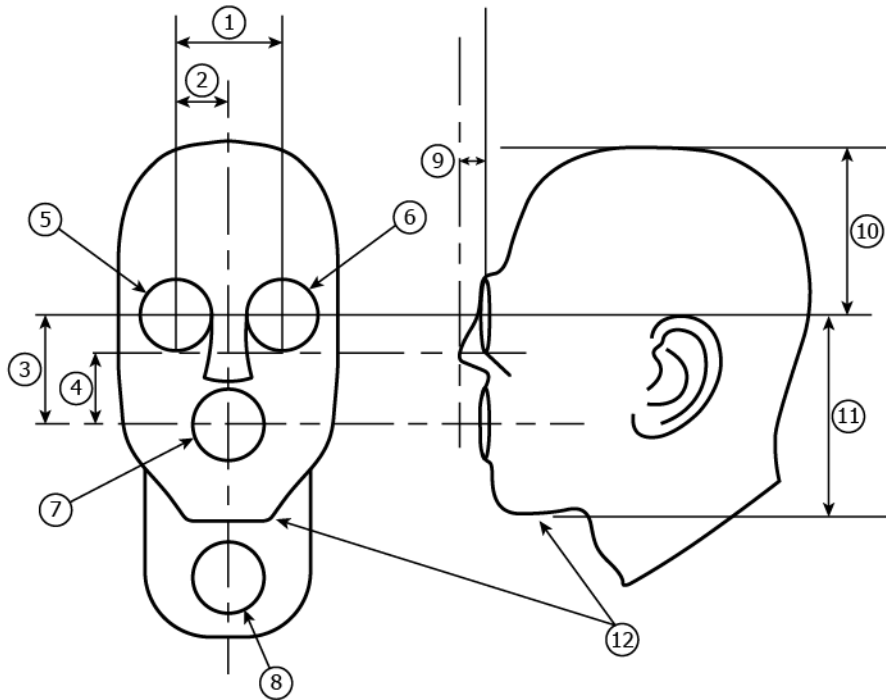

1	7.6 cm [3 in.]	7	Mouth Sensor
2	3.8 cm [1.5 in.]	8	Neck Sensor (Optional)
3	5.1 cm [2 in.]	9	3.2 cm [1.25 in.]
4	2.5 cm [1 in.]	10	10.8 cm [4.25 in.]
5	Right Eye	11	10.2 cm [4 in.]
6	Left Eye	12	Chin Sensor

FIG. 41 Mannequin Head and Head Sensor Locations

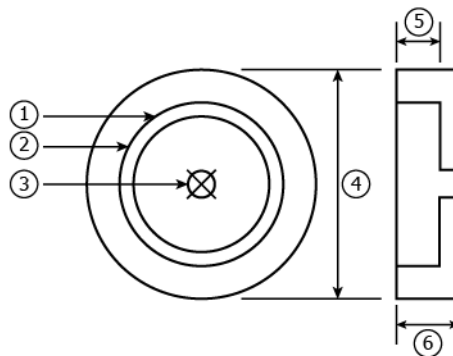

1	4 cm [1.57 in.]	4	51 mm [2 in.]
2	1.6 mm [1/16 in.] × 1.6 mm [1/16 in.] Ledge	5	19 mm [¾ in.] [6.4 mm [1/4 in.] insulation behind Calorimeter]
3	3.2 mm [1/8 in.]	6	2.5 cm [1 in.]

FIG. 52 Sensor Mount

TABLE 2 Subjective Material Evaluation of Eye or Face Protective Products

	Subjective Material Evaluations at or above Arc Rating	
	Arc Exposure # 1	Arc Exposure # 2
	Incident Energy, cal/cm ²	
After flame time, s		
Breakopen (yes/no) and size in cm [in.]		
Melting (yes/no)		
Dripping (yes/no)		
Deformation of window (yes/no)		
Fabric Shrinkage, %		
Electric Arc Ignition (yes/no)		

TABLE 3 Thermal Conductivity in accordance with Test Method C177 at Various Mean Temperatures

Temperature	Thermal Conductivity Btu-in./ft ² h, °F [W/m °K]
75°F [24°C]	1.15 [0.17]
400°F [205°C]	1.13 [0.16]
600°F [316°C]	1.15 [0.17]
800°F [425°C]	1.16 [0.17]
1000°F [538°C]	1.17 [0.17]

9. Calibration and Standardization

9.1 *Data Collection System Precalibration*—The data collection system shall be calibrated by using a thermocouple calibrator/simulator. This will allow calibrations to be made at multiple points and at levels above 100°C. Due to the nature of the tests, frequent calibration checks are recommended.

9.2 *Calorimeter Calibration Check*—Calorimeters shall be checked to verify proper operation. Measure and graph the temperature rise of each calorimeter and system response. At 30 s, no one calorimeter response shall vary by more than 4°C from the average of all calorimeters. Any calorimeter not meeting this requirement shall be suspected of faulty connections and shall be replaced or repaired.

NOTE 3—One acceptable method is to expose each calorimeter to a fixed radiant energy source for 30 s. For example, place the front surface of a 500 W spot light⁴ 26.7 cm [10.5 in.] from the calorimeter. The spot shall be centered on and perpendicular to the calorimeter.

9.3 *Arc Exposure Calibration*—Prior to each calibration, position the electrodes of the test apparatus to produce a 30.5 cm [12-in.] gap. The face of the monitor sensors shall be parallel and normal to the centerline of the electrodes. The midpoint of the electrode gap shall be at the same elevation as the center point of the monitor sensors. (See Fig. 2.) Connect the fuse wire to the end of one electrode by making several wraps and twists and then to the end of the other electrode by the same method. The fuse wire shall be pulled tight and the excess trimmed. Adjust the test controller to produce the desired arc current and duration.

9.4 *Apparatus Calibration for the Four-Sensor Head and Monitor Sensors*—Position each four-sensor head so that the surface of each head is 30.5 cm [12 in.] from, parallel and normal to, the centerline of the electrodes.

9.4.1 Set the symmetrical arc exposure current to 8000 ± 500 A and the arc duration at 10 cycles [0.167 s].

9.4.2 Discharge the arc.

9.4.3 Determine the maximum temperature rise for each of the sensors, and multiply by the appropriate factor, to obtain the total incident energy J/cm² [cal/cm²] measured by each sensor.

9.4.4 Compare the highest sensor reading and the average value obtained for all sensors, (excluding the chin sensor), for example, with the theoretical result of 42.3 J/cm² [10.1 cal/cm²] for the calibration exposure of 8kA for 0.167 s. Compare the total heat value determined by the sensors to the value shown.

9.4.5 The average total heat calculated for the sensors shall be at least 60 % of the value determined by calculation or that shown. The highest measured total heat of any one sensor shall be within 10 % of the calculated value. If these values are not obtained, inspect the test setup and correct any possible problems that could produce less than desired results.

9.4.6 An arc exposure calibration test should be conducted at the desired test level after each adjustment, and prior to the start and end of each day's testing and after any equipment adjustment or failure.

⁴ Available from American National Standards Institute (ANSI), 25 W. 43rd St., 4th Floor, New York, NY 10036, <http://www.ansi.org>.

9.4.7 The arcs generated in the testing apparatus may not follow a path that is equidistant from each sensor and can result in a variation in measured values. To be considered calibrated, the highest total heat measured from any single sensor from a 10 cycle, 8000 A fault current shall not exceed 46.1 J/cm^2 [11 cal/cm^2] and the average total heat measured for all sensors in the apparatus shall be at least 25.1 J/cm^2 [6 cal/cm^2]. If these values are not achieved, check the calibration of the sensor system, electrical conditions, and the physical setup of the apparatus and repeat the calibration exposure until the required results are obtained.

9.4.8 If during testing the exposure values specified in 9.4.5 are not achieved in three consecutive tests, then suspend testing and re-calibrate the system. If a change is made as a result of the re-calibration, reject the data from the last three tests.

9.5 *Confirmation of Test Apparatus Setting*—Confirm the test apparatus setting for each test from the controller equipment. Report the values for peak arc current, RMS arc current, arc duration, arc energy, and arc voltage. Plot a graph of the arc current to ensure proper wave form. Record ambient temperature and relative humidity.

10. Apparatus Care and Maintenance

10.1 *Initial Temperature*—Prior to each test, confirm that the sensors are at a temperature of 15 to 35°C. If necessary, the sensors shall be cooled with a jet of air or by contact with a cold surface.

10.2 *Surface Reconditioning*—While the sensor is hot, wipe the sensor face immediately after each test to remove any decomposition products that condense and could be a source of future measurement error. If a deposit collects and appears to be thicker than a thin layer of paint or the surface appears irregular, the sensor surface requires reconditioning. Carefully clean the cooled sensor with acetone or petroleum solvent, making certain to follow safe handling practices. Repaint the surface as noted in 6.2.1. Perform an arc exposure to cure the paint and check calibration according to 9.3 after resurfacing the sensors.

10.3 *Sensor Care*—The sensors shall be kept dry. For outdoor tests, the mannequin heads and monitor sensors shall be covered during long periods between tests to prevent excess temperature rise resulting from exposure to the sun. Due to the destructive nature of the electric arc, the mannequin and head should be covered with the same paint as the sensors. The heads should be re-coated periodically to reduce mannequin deterioration.

11. Procedure

11.1 *Arc Rating of Eye or Face Protective Products*

11.1.1 Test specimens shall be exposed to an electric arc. Record the readings of the eye, mouth, and chin sensors.

11.2 Test parameters shall be $8 \pm 1 \text{ kA}$ arc current, 30.5 cm [12 in.] electrode gap, stainless steel electrodes, 30.5 cm [12 in.] distance between the arc center line and the facial plane. In addition to the standard set of exposure conditions, other conditions representative of the expected hazard may be used and shall be reported should this data be cited, but may not be used in determination and reporting of a standard arc rating.

11.3 *Order of Tests*

11.3.1 Each test shall consist of two or three specimens of the same test specimen, one for each of the four sensor heads.

11.3.2 To evaluate a single sample of a test specimen, a series of at least seven tests shall be run over a range of incident energies. A minimum of 20 average incident energy monitor and lower reading four sensor head sensor readings results meeting 11.3.2.2 through 11.3.2.4 is required for an ATPV determination. All four sensors are used in evaluation of hoods; only the two eye sensors are used in calculations for safety spectacles and goggles.

11.3.2.1 The incident energy range shall be achieved by increasing or decreasing the arc duration (cycles).

11.3.2.2 The measured incident energy (average value of the two respective monitor sensors) on at least 15 % of the four-sensor heads exposed must result in values that always exceed the Stoll curve predicted second-degree burn injury criteria (as determined by 12.1.4). In other words, values in this energy range always exceed the Stoll criteria.

11.3.2.3 The measured incident energy (average value of the two respective monitor sensors) on at least 15 % of the four-sensor heads exposed must result in values that never exceed the Stoll curve predicted second-degree burn injury criteria (as determined by 12.1.4). In other words, values in this energy range never exceed the Stoll criteria.

11.3.2.4 The measured incident energy (average value of the two respective monitor sensors) on at least 50 % of the four-sensor heads exposed shall result in values that are approximately equally populated within $\pm 20 \%$ of the final ATPV (as determined by 12.1.4; see 11.3.6, Discussion). Values in this energy range typically have mixed results—some values exceed and some values do not exceed the Stoll criteria.

11.3.3 All data points are valid unless a copper calorimeter temperature exceeds 500°C for the monitor sensor described in 6.3.1, there is a malfunction of the test or data acquisition equipment, or the specimen mounting fails.

11.3.4 If more than the minimum number of tests are performed, for whatever reason, all valid data points shall be used (see 11.3.6, Discussion).

11.3.5 Handling data from specimens that exhibit breakopen or underlayer ignition (multilayer systems).

11.3.5.1 Specimens that exhibit breakopen or underlayer ignition (multilayer systems) are valid data points for ATPV determination.

11.3.5.2 If two or more occurrences of material breakopen are noted at incident energies below a value of 20 % above the ATPV determination, a breakopen response shall be determined. In this case, more than ten tests may be required so that the breakopen response can be evaluated (above or below the Stoll curve criteria, see 12.2 for treatment of breakopen).

11.3.6 *Discussion*—An iterative process will be needed to achieve the requirement that 50 % of the data points are within 20 % of the material systems ATPV. After the first two are exposures (4 four-sensor heads exposures) are completed, assuming response above and below the Stoll curve criteria, an estimated ATPV can be determined. Using this estimation, the remaining tests can be selected so that 50 % of the four sensor head data fall within 20 % of the ATPV, for example, if the approximated ATPV is 6.5 cal/cm² [27.2 J/cm²] then test parameters are selected so that the incident energies on the four sensor heads will fall within the range of 5.2 to 7.8 cal/cm² [21.8 to 32.7 J/cm²]. As each successive test is performed, the accuracy of the ATPV estimation will improve so that the incident energy target range of ATPV ±20 % can also be more accurately established. The goal is to achieve the required 50 % of the data within 20 % of ATPV by the time the required 20 data points are complete. Generally, assuming all data points are valid, this would mean that 11 of the 21 data points would need to have incident energy values within 20 % of the ATPV. In the example above, 11 of the data points would need to have incident energy values within the range of 5.2 to 7.8 cal/cm² [21.8 to 32.7 J/cm²] for a material with an ATPV of 6.5 cal/cm² [27.2 J/cm²]. If less than 11 data points fall in this range, additional tests will be needed until 50 % of the total data points have incident energy values within 20 % of the ATPV.

11.3.6.1 A least-squares fit of the maximum difference between the highest measured four-sensor head sensor thermal energy response and the corresponding Stoll response (independent value) and the average measured incident energy for each four sensor head (dependent variable) can be used to guide the selection of appropriate incident exposure energies. The y-intercept value is the approximate ATPV result.

11.4 Heat Transfer Determination with the Four-Sensor Head Test:

11.4.1 Adjust the temperature of the sensors to between 25 to 35°C.

11.4.2 *Specimen Mounting*—The specimen shall be placed on the test head in the manner in which the product is to be worn.

11.5 *Specimen Data*—Record specimen data including: (1) identification number, (2) the order of layering (for layered systems) with outer layer listed first, (3) material type, (4) faceshield/window safety spectacle or goggle specimen thickness before testing, (5) weave/knit type of hood material(s), (6) color, and (7) number of specimens tested.

11.6 Mount the fuse wire on electrodes.

11.7 Exercise all safety precautions and ensure all persons are in a safe area.

11.8 Expose test specimens to the electric arc.

11.9 Shut off the electric supply, ventilate the test area at the completion of the data acquisition period, and apply the protective grounds. (Refer to Section 7).

11.10 Extinguish any flames or fires unless it was predetermined to let the specimen(s) burn until consumed.

11.11 Record the thermal and electrical data and material response as required in Section 13.4e/astm-f2178-f2178m-20

11.11.1 *Sensor Response*—The sensor response of each calorimeter is determined shortly before, during, and for 30 s after an arc thermal exposure has been initiated.

11.11.2 Once the arc initiation point is determined, the temperature data collected from the calorimeters before and up to the initiation point are averaged to obtain a starting calorimeter temperature, T_{initial} (°C) for each respective sensor.

11.11.3 The heat capacity in cal/g°C of each copper slug calorimeter at the initial temperature is calculated using:

$$C_p = \frac{(A + B \times t + C \times t^2 + D \times t^3 + E/t^2)}{63.546 \text{ g/mol}} \quad (1)$$

where:

t = (measured temperature °C + 273.15) / 1000;

A = 4.237312;

B = 6.715751;

C = -7.46962;

D = 3.339491, and

E = 0.016398.

11.11.3.1 *Discussion*—The heat capacity of copper in cal/g°C at any temperature between 289 and 1358 K is determined via Eq 1 (Shomate equation with coefficients from NIST). The value in J/g°C can be obtained by multiplying the result in Eq 1 by 4.1868 J/cal.

11.11.4 The copper slug heat capacity is determined at each time step for all the copper slug calorimeters (monitor and four-sensor head sensors). This is done by calculating an average heat capacity for each sensor from the initial heat capacity, determined in 11.11.3, and the time step measured temperature:

$$\bar{C}_p = \frac{C_p @ \text{Temp}_{\text{initial}} + C_p @ \text{Temp}_{\text{final}}}{2} \quad (2)$$