



Designation: **D7935/D7935M – 14 D7935 – 20**

## Standard Test Method for Corrosion Test for Non-Aqueous Engine Coolants in Glassware<sup>1</sup>

This standard is issued under the fixed designation ~~D7935/D7935M~~; D7935; the number immediately following the designation indicates the year of original adoption or, in the case of revision, the year of last revision. A number in parentheses indicates the year of last reapproval. A superscript epsilon ( $\epsilon$ ) indicates an editorial change since the last revision or reapproval.

### 1. Scope

1.1 This test method covers a simple beaker-type procedure for evaluating the effects of non-aqueous engine coolants on metal specimens under controlled laboratory conditions (see [Appendix X1](#)).

NOTE 1—For more information on aqueous and non-aqueous engine coolants, see (Refs [1-9](#)).<sup>2</sup>

1.2 The values stated in ~~either SI units or inch-pound units~~ are to be regarded ~~separately~~ as standard. The values stated in each system are not necessarily exact equivalents; therefore, to ensure conformance with the standard, each system shall be used independently of the other, and values from the two systems shall not be combined. Some values have only SI units because the inch-pound equivalents are not used in practice. given in parentheses after SI units are provided for information only and are not considered standard.

1.3 *This standard does not purport to address all of the safety concerns, if any, associated with its use. It is the responsibility of the user of this standard to establish appropriate ~~safety~~ safety, health, and ~~health~~ environmental practices and determine the applicability of regulatory limitations prior to use.* Some specific hazards statements are given in [10.1.7.2](#), [10.1.7.3](#), and [10.1.7.4](#).

1.4 *This international standard was developed in accordance with internationally recognized principles on standardization established in the Decision on Principles for the Development of International Standards, Guides and Recommendations issued by the World Trade Organization Technical Barriers to Trade (TBT) Committee.*

### 2. Referenced Documents

2.1 *ASTM Standards:*<sup>3</sup>

[B32](#) Specification for Solder Metal

[B36/B36M](#) Specification for Brass Plate, Sheet, Strip, and Rolled Bar

[D1176](#) Practice for Sampling and Preparing Aqueous Solutions of Engine Coolants or Antirusts for Testing Purposes

[D1384](#) Test Method for Corrosion Test for Engine Coolants in Glassware

[E1](#) Specification for ASTM Liquid-in-Glass Thermometers

[E178](#) Practice for Dealing With Outlying Observations

[E230/E230M](#) Specification for Temperature-Electromotive Force (emf) Tables for Standardized Thermocouples

2.2 *ASTM Adjunct:*<sup>4</sup>

All-glass apparatus for corrosion test (2 drawings)

### 3. Summary of Test Method

3.1 In this test method, specimens of metals typical of those present in engine cooling systems are totally immersed in aerated engine coolant solutions for 336 h at ~~96°C [205°F]~~; 96 °C (205 °F). The corrosion-inhibitive properties of the test solution are evaluated on the basis of the weight changes incurred by the specimens. Each test is run in triplicate, and the average weight change is determined for each metal. A single test may occasionally be completely out of line (see [11.3](#)).

<sup>1</sup> This test method is under the jurisdiction of ASTM Committee [D15](#) on Engine Coolants and Related Fluids and is the direct responsibility of Subcommittee [D15.22](#) on Non-Aqueous Coolants.

Current edition approved ~~June 1, 2014~~ June 1, 2020. Published ~~August 2014~~ June 2020. Originally approved in 2014. Last previous edition approved in 2014 as [D7935/D7935M-14](#). DOI: ~~10.1520/D7935-D7935M-14~~ 10.1520/D7935-20

<sup>2</sup> The boldface numbers in parentheses refer to the list of references at the end of this standard.

<sup>3</sup> For referenced ASTM standards, visit the ASTM website, [www.astm.org](http://www.astm.org), or contact ASTM Customer Service at [service@astm.org](mailto:service@astm.org). For *Annual Book of ASTM Standards* volume information, refer to the ~~standard's~~ standard's Document Summary page on the ASTM website.

<sup>4</sup> Available from ASTM International Headquarters. Order Adjunct No. [ADJD1384](#). Original adjunct produced in 1980.

#### 4. Significance and Use

4.1 This test method will generally distinguish between non-aqueous coolants that are definitely deleterious from the corrosion standpoint and those that are suitable for further evaluation. However, the results of this test method cannot stand alone as evidence of satisfactory corrosion inhibition. The actual service value of an engine coolant formulation can be determined only by more comprehensive bench, dynamometer, and field tests.

#### 5. Apparatus

5.1 *Container*, a ~~1000-mL~~ 1000 mL, tall-form, spoutless beaker, made of heat-resistant glass, for containing the non-aqueous engine coolant solution and test specimens. The beaker shall be tightly closed with a No. 15 rubber stopper, having drill holes to accommodate a water condenser, an aerator tube, and a temperature measuring instrument as shown in Fig. 1. Optionally, an all-glass apparatus may be used.<sup>4</sup>

5.2 *Condenser*, a water condenser of the reflux, glass-tube type, having a ~~400-mm~~ 400 mm (16 in.) condenser jacket.

5.3 *Aerator Tube*, a gas-dispersion tube, porosity size 12-C,<sup>5</sup> to ensure continuous aeration without plugging.

5.4 *Temperature Measuring Instrument (Environmentally Safe Thermometer or Thermocouple)*, an ASTM Partial Immersion Temperature Measuring Instrument having a range from ~~-20~~ -20 °C to ~~150~~ 150 °C (0 °F to ~~302~~ 302 °F) and conforming to the requirements for Thermometer ~~1°C~~ 1°C (1°F), as prescribed in Specification E1 or Thermocouple as summarized in Specification E230/E230M.

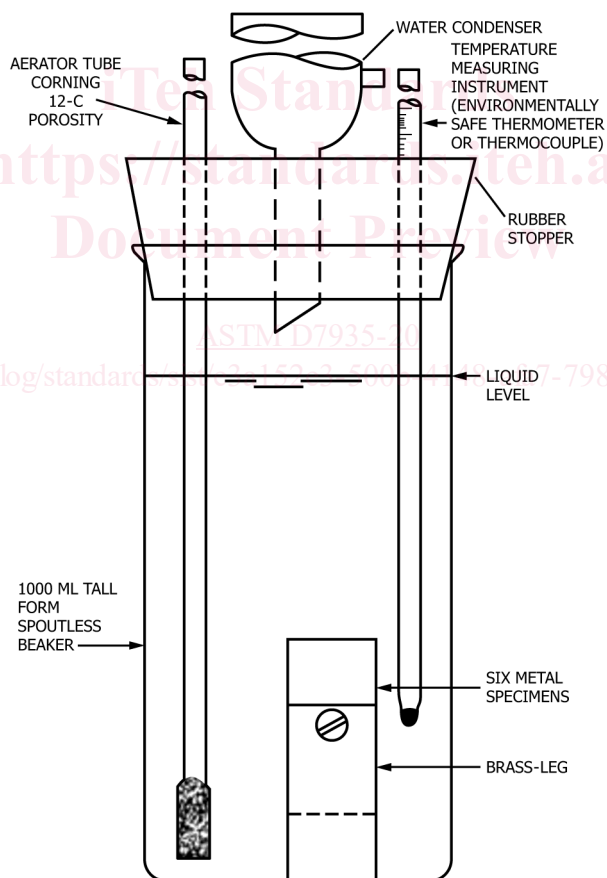

FIG. 1 Metal Specimens and Equipment for ~~336-h~~ 336 h Corrosion Test

<sup>5</sup> The sole source of supply of the apparatus known to the committee at this time is Corning Glass Works, 44-5 Crystal St., Corning, NY 14830. Gas-dispersion tube No. 39533, manufactured by Corning Glass Works, has generally been found satisfactory for this purpose. Optionally, a capillary tip bleed tube with ~~7-mm~~ 7 mm (0.28 in.) bore and ~~280-mm~~ 280 mm (11 in.) length may be used when consistent early plugging of gas dispersion tubes occurs. The tube, catalog No. 7815-19, may be obtained from Corning Glass Works. If you are aware of alternative suppliers, please provide this information to ASTM International Headquarters. Your comments will receive careful consideration at a meeting of the responsible technical committee,<sup>1</sup> which you may attend.

5.5 *Heater*, a constant-temperature bath containing a high-boiling liquid that is capable of giving continuous service with the specified temperature control.<sup>6</sup> The size of the bath will be determined by the number of corrosion tests that are to be run concurrently.

**6. Metal Test Specimens**

NOTE 2—The specimens prescribed in this test method have been accepted by automobile manufacturers, but their composition may not be the same as that of alloys currently used for engine cooling system components. Therefore, specimens other than those designated in this test method may be used by mutual agreement of the parties involved.

6.1 *Type*—The following metal test specimens,<sup>7</sup> representative of cooling system metals, shall be used:

6.1.1 *Steel*, UNS G10200 (SAE 1020),<sup>8</sup> cut from ~~1.59-mm~~ 1.59 mm (1/16-in.) cold-rolled sheet stock to size ~~50.850.8 mm~~ by 25.4 mm {2(2 in. by 1 in.)}. Chemical composition of the carbon steel is as follows: carbon, 0.17 to 0.23 %; manganese, 0.30 to 0.60 %; phosphorus, 0.040 % maximum; sulfur, 0.050 % maximum.

6.1.2 *Copper*, conforming to UNS C11000 (SAE CA110)<sup>8</sup> or UNS C11300 (SAE CA113).<sup>8</sup> Cold-rolled, cut from ~~1.59-mm~~ 1.59 mm (1/16-in.) sheet stock to size ~~50.850.8 mm~~ by 25.4 mm {2(2 in. by 1 in.)}.

6.1.3 *Brass*, conforming to Alloy UNS C26000 (SAE CA 260). Half-hard, cut from ~~1.59-mm~~ 1.59 mm (1/16-in.) sheet stock to size ~~50.850.8 mm~~ by 25.4 mm {2(2 in. by 1 in.)}.

6.1.4 *Solder*—A brass specimen as described in 6.1.3, coated with solder conforming to Alloy Grade 30A (SAE 3A) of Specification B32. Solder-coated specimens may be prepared, or used specimens recoated for reuse, by the procedure given in Annex A1. A solid solder specimen cut from ~~1.59-mm~~ 1.59 mm (1/16-in.) sheet stock of Alloy Grade 30A (SAE 3A) to size ~~50.850.8 mm~~ by 25.4 mm {2(2 in. by 1 in.)} may be used subject to mutual agreement of the parties involved. The use of a solid solder specimen must be reported along with the metal specimen weight loss results.

6.1.4.1 When agreed upon between the supplier and the purchaser of engine coolants, the standard solder specimen may be replaced with one having a different alloy composition than standard Alloy Grade 30A or 30B. Use of specimens other than standard Alloy Grade 30A or 30B shall be noted in the test report.

NOTE 3—Where non-standard alloy is used, the standard flux shown in A1.1.5 may not be satisfactory. A low corrosive flux may be required.

6.1.5 *Cast Aluminum*, conforming to Alloy UNS A23190 (SAE 329).<sup>8</sup> Specimen size, ~~50.850.8 mm~~ by ~~25.425.4 mm~~ by 3.18 mm {2(2 in. by 1 in. by 1/8 in.)}.

6.1.6 *Cast Iron*, conforming to Alloy UNS F10007 (SAE G3500).<sup>7</sup> Specimen size, ~~50.850.8 mm~~ by ~~25.425.4 mm~~ by 3.18 mm {2(2 in. by 1 in. by 1/8 in.)}.

6.2 *Arrangement* (See Fig. 2):

6.2.1 *Metal Specimen Arrangement*—None of the hardware used in metal specimen arrangement (metal specimen, screws, washers, metal spacers, insulating sleeves, insulating spacers and nuts) can be reused for a test. The metal test specimens shall be drilled through the center with a ~~6.75-mm~~ 6.75 mm (1/64-in.) drill to accommodate a ~~50.8-mm~~ 2-in. ~~50.8 mm~~ (2 in.) 10–24

<https://standards.iteh.ai/catalog/standards/sist/e3a152e3-500b-4148-afa7-7988687ecad2/astm-d7935-20>

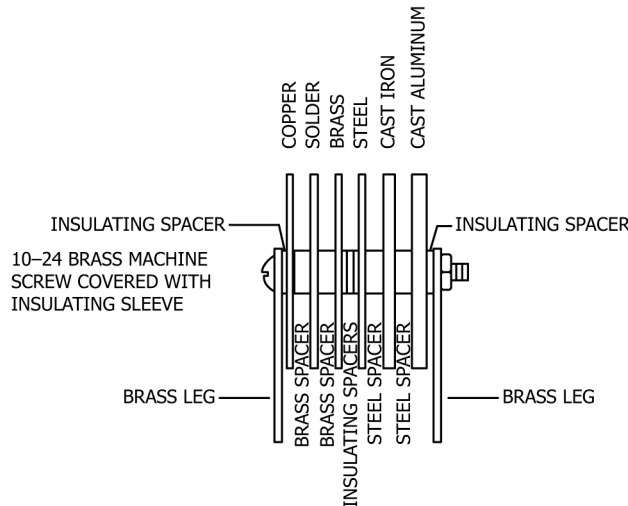

FIG. 2 Metal Specimen Arrangement

<sup>6</sup> If a water bath is used, a significant reduction in evaporation rate is achieved by addition of floating plastic chips on the water surface.

<sup>7</sup> Complete sets or individual metal test specimens are available from (a) Chemical Specialties Manufacturers Association, Inc., Suite 1120, 1001 Connecticut Ave., N.W., Washington, DC 20036; (b) Astro-Mechanics, Inc., 8500 Research Blvd., Austin, TX 78766; (c) The Metaspac Company, P.O. Box 27707, San Antonio, TX 78227; or (d) Metal Samples Co. Inc., P.O. Box 8, Munford, AL 36268.

<sup>8</sup> Unified Numbering System for Metals and Alloys, SAE-ASTM, July 1995.

brass machine screw covered with a thin-walled insulating sleeve. Polytetrafluoroethylene tubing with a ~~6.35-mm~~ {6.35 mm (1/4-in.)} outside diameter ~~1.59-mm~~ {1.59 mm (1/16-in.)} wide and a wall thickness of 0.4 mm {1/64-in.} is satisfactory. Two half-hard brass legs shall be cut from ~~1.59-mm~~ {1.59 mm (1/16-in.)} sheet stock to size ~~50.8~~ 50.8 mm by 25.4 mm {2 in. by 1 in.}. A ~~6.35-mm~~ {6.35 mm (1/4-in.)} diameter hole shall be drilled in each leg with the center 6.35 mm {1/4 in.} from the top and 12.7 mm {1/2 in.} from each side. The test “bundle” shall be made up on the insulated screw with the specimens in the following order: brass leg, copper, solder, brass, steel, cast iron, cast aluminum, and brass leg. The specimens shall be separated by ~~4.76-mm~~ {4.76 mm (3/16-in.)} thick solid metal spacers having a ~~6.75-mm~~ {6.75 mm (17/64-in.)} inside diameter and a ~~11.11-mm~~ {11.11 mm (7/16-in.)} outside diameter. Insulating spacers made from polytetrafluoroethylene shall be used between the brass legs and the specimen “bundle,” and between the brass and steel specimens. Brass spacers shall be used between the brass, solder, and copper specimens, and steel spacers between the cast iron, steel, and cast aluminum specimens. The nut shall be tightened firmly to ensure good electrical contact between the test specimens in each section of the “bundle.”

6.2.2 *Alternate Metal Specimen Arrangement*—When agreed upon between the supplier and the purchaser, an alternate metal specimen arrangement may be used to evaluate multiple solder alloys, such as high lead Alloy Grade L50113 consisting of 97 % lead, 2.5 % tin, 0.3 % silver, concurrently with Standard Alloy Grade 30A or 30B. It is recommended that the metal specimen arrangement be modified by replacing the copper specimen with the high lead solder specimen and arranging specimens in the bundle as follows:

High Lead Solder	Brass	Alloy Grade 30A or 30B	Steel	Cast Iron	Cast Aluminum
---------------------	-------	---------------------------	-------	-----------	------------------

Use of alternate specimens and metal specimens arrangements shall be noted in the test report.

## 7. Preparation of Test Specimens

7.1 Sand the cast iron and cast aluminum specimens on the ~~25.4~~ 25.4 mm by ~~50.8-mm~~ {50.8 mm (1 in. by 2-in.)} cut surfaces with “coarse” grade (No. 1) emery cloth. Remove any burrs from coupon edges and hole. Scrub all specimens vigorously, using a moistened bristle brush and ground pumice powder or fine silicon carbide grit until the entire metal area is bright, shiny, and free from any visible oxide film or tarnish.

7.2 Rinse the specimens thoroughly with tap water; then rinse with acetone, dry, and weigh to the nearest 1 mg. Cast aluminum specimens should be dried in a ~~100°C~~ 100 °C oven for 1 h, to a constant weight, prior to recording the weight.

NOTE 4—If the test specimens are not to be used immediately, keep them in a desiccator until required.

## 8. Test Solutions

8.1 The concentration of the non-aqueous engine coolant to be tested shall be as follows:

8.1.1 *Engine Coolant*—The non-aqueous coolant shall be mixed with the proper quantity of corrosive water to give a test solution containing a mixture of 94 volume % non-aqueous coolant with six volume % corrosive water.

8.1.2 *Corrosive Water* (Note 5)—The corrosive water shall contain 100 ppm each of sulfate, chloride, and bicarbonate ions introduced as sodium salts.

8.2 *Preparation of Sample*—The preparation of the sample shall be done in accordance with ~~Test Method Practice D1176~~, except that the corrosive water shall be used for dilution instead of distilled water. Thus, any insoluble materials will be included in the representative sample.

NOTE 5—The specified corrosive water can be prepared by dissolving the following amounts of anhydrous sodium salts in a quantity of distilled or deionized water.

sodium sulfate	148 mg
sodium chloride	165 mg
sodium bicarbonate	138 mg

The resulting corrosive water solution should be made up to a volume of 1 L with distilled or deionized water at ~~20°C~~ 20 °C.

8.2.1 If relatively large amounts of corrosive water are needed for testing, a concentrate may be prepared by dissolving ten times the above amounts of the three chemicals, in distilled or deionized water, and adjusting the total volume to 1 L by further additions of distilled or deionized water. When needed, the water concentrate is diluted to the ratio of one part by volume of concentrate to nine parts of distilled or deionized water.

## 9. Test Conditions

9.1 *Beaker Assembly*—The arrangement of the assembled metal specimens with relation to the aerator tube and other components is shown in Fig. 1. Note that the tip of the condenser just emerges from the bottom of the rubber stopper.

9.2 *Test Temperature*—The test solution shall be maintained at a temperature of ~~96°C~~ 96 °C ± 2°C {205 °F ± 5°F} 4 °F.

9.3 *Aeration Rate*—The aeration rate shall be ~~100~~ 100 mL/min ± 10 mL/min. The aerator tube should be located at least 12.7 mm {1/2 in.} away from the test “bundle” to avoid direct contact with the metal specimens.

9.4 *Test Duration*—The test shall be run continuously for 2 weeks (336 h).

## 10. Procedure

10.1 Make triplicate tests concurrently on each engine coolant solution in accordance with the following procedure:

10.1.1 Carefully clean the test beaker, condenser, rubber stopper, and aerator tube, and thoroughly rinse with water. Ensure all components are dry before use.

10.1.2 Bolt the specimens together in the order given in 6.2 and place the “bundle” in the test beaker as shown in Fig. 1.

10.1.3 Pour 750 mL of the prepared test solution into the ~~1000-mL~~ 1000 mL beaker.

10.1.4 Fit the condenser and aeration tube to the beaker, and set the aeration rate at 100 mL/min, using a flow meter or other suitable device.

10.1.5 Raise the temperature of the test solution to ~~96°C [205°F] for high-boiling engine coolants.~~ 96 °C (205 °F). Pass water through the condenser at a rate sufficient to maintain adequate cooling.

10.1.6 Check the tests once each working day to ensure proper solution temperature, aeration rate, and solution level. The tests may operate unattended on weekends and holidays. Make up evaporation losses during the corrosion tests by addition of distilled or deionized water.

10.1.7 At the end of the test, immediately disassemble specimens and brush very lightly with a soft bristle brush and water to remove loosely held corrosion products. To remove the more tenacious corrosion products and films, the individual specimens shall then be subjected to additional cleaning treatments as follows:

10.1.7.1 *Iron and Steel*—Remove adherent deposits by means of a brass scraper or brass bristle brush, followed by scrubbing with a wet bristle brush and fine pumice to clean the specimen completely.

10.1.7.2 *Copper and Brass*—Dip in a 1 + 1 mixture of concentrated HCl (sp gr 1.19) and water for 15 s to remove tarnish films, rinse with tap water to remove acid, and scrub with a wet bristle brush and fine pumice powder. (**Warning**—HCl is a strong acid. Avoid contact with skin and eyes. Handle in a fume hood.)

10.1.7.3 *Aluminum*—In a fume hood, dip for 10 min in an aqueous solution containing four parts concentrated nitric acid (HNO<sub>3</sub>, 70 mass %) plus one part distilled water at ~~25°C [77°F].~~ 25 °C (77 °F). Rinse thoroughly with water, then brush very lightly with a soft bristle brush to remove any loose films, and again rinse with water.<sup>9</sup> Dry the specimen in a ~~100°C~~ 100 °C oven for 1 h, to a constant weight prior to recording the weight. (**Warning**—HNO<sub>3</sub> is a strong toxic oxidant and acid. Avoid contact with skin, eyes, and clothing. Do not breathe vapor. Handle in a fume hood.)

10.1.7.4 *Solder*—Immerse for 5 min in boiling 1 % glacial acetic acid. Rinse in water to remove the acid, and brush very gently with a soft bristle brush to remove any loosened material. (**Warning**—Avoid contact with skin and eyes with glacial acetic acid. Handle in a fume hood.)

10.1.8 The acid dip times given in 10.1.7 for the cleaning of nonferrous specimens are average values found to be adequate in most cases. Other times, suggested by experience, may be used if necessary, if gross weight losses are adjusted by the appropriate tare.

10.1.9 Follow each of the four operations noted above by thorough rinsing, first in tap water and then in acetone. Then dry and weigh the specimens to the nearest 1 mg. Store in a desiccator specimens that cannot be weighed immediately.

<https://standards.iteh.ai/catalog/standards/sist/e3a152e3-500b-4148-afa7-7988687ecad2/astm-d7935-20>

<sup>9</sup> A round-robin evaluation of nitric acid cleaning of aluminum specimens is available from ASTM International Headquarters. Request RR:D15-1018.

10.1.10 Because cleaning methods and materials may vary among laboratories, occasionally determine cleaning losses obtained by a particular operator on an untested set of triplicate metal specimens. Deduct the average cleaning losses from gross weight differences to determine actual corrosion losses.

## **11. Report**

11.1 Report the following information:

11.2 Report corrosion weight loss as a positive value and weight gain as a negative value. If no sign is given to the value it will be interpreted as a weight loss. Example: Initial weight of a brass specimen after cleaning was 405 mg. At the end of test after cleaning it was 398 mg. The cleaning blank was determined by taking the weight of a brass specimen after the initial cleaning, 406 mg, and then cleaning it alongside of the brass specimen removed at the end of the test, 404 mg. Using **Eq 1**, calculate the weight change of the specimen.

# iTeh Standards (<https://standards.iteh.ai>) Document Preview

[ASTM D7935-20](#)

<https://standards.iteh.ai/catalog/standards/sist/e3a152e3-500b-4148-afa7-7988687ecad2/astm-d7935-20>



$$\begin{aligned}
 & (\text{Initial weight} - \text{end of test weight}) - \\
 & (\text{Cleaning blank} - \text{cleaning blank recleaned alongside} \\
 & \quad \text{of end of test specimen}) = \text{Final reported weight change} \\
 & (405 \text{ mg} - 398 \text{ mg}) - (406 \text{ mg} - 404 \text{ mg}) = 5 \text{ mg} \\
 & (\text{positive value means that it is a weight loss}) \tag{1}
 \end{aligned}$$

11.2.1 Report the corrected corrosion weight changes of individual specimens to the nearest 1 mg for each test.

11.3 Report the average corrected metal weight change for triplicate tests on each engine coolant solution. A single weight change that appears completely out of line should be dealt with as described in Practice E178.

## 12. Precision and Bias

12.1 As indicated in 1.1, this test method is intended only as a rough screening tool. The precision and bias of the procedure in this test method will be determined.

## 13. Keywords

13.1 anhydrous; engine coolants; glassware corrosion test; non-aqueous

## ANNEX

### (Mandatory Information)

#### A1. PROCEDURE FOR PREPARATION OR RECOATING OF SOLDER-COATED BRASS SPECIMENS

##### A1.1 Preparation

A1.1.1 Shear ~~50.8 mm~~ 50.8 mm by ~~25.4 mm~~ 25.4 mm (2 in. by ~~1 in.~~ 1 in.) half hard brass specimen from ~~1.59 mm~~ 1.59 mm (1/16 in.) sheet stock conforming to Alloy No. 8 of Specification B36/B36M, UNS C26000 (SAE CA 260).

A1.1.2 Drill a ~~6.9 mm~~ 6.9 mm (0.272 in.) diameter hole (letter “I”) drill in the center of each specimen.

A1.1.3 Smooth the edges and holes.

A1.1.4 Remove tarnish and other surface films by scrubbing the brass specimens with a bristle brush, fine pumice and water. Scrub using a bristle brush followed by a thorough water rinse. Dry specimens by immersing into acetone and air drying. Store in a desiccator until required.

A1.1.5 Immerse brass specimens to be coated by the Alloy Grade 30A solder in a 25 % aqueous solution of acid chloride flux. The composition of the flux is 40 % zinc chloride, 3 % ammonium chloride, 1.5 % hydrochloric acid, and 55.5 % water. A 25 % aqueous solution of low corrosive flux<sup>10</sup> may be substituted for the acid chloride flux.

A1.1.5.1 Use a suitable flux for other grades of solder. For example, a low corrosive flux<sup>10</sup> is preferred for Alloy Grade L50113<sup>8</sup> (97 % lead - 2.5 % tin - 0.5 % silver).

A1.1.6 Mount the specimen on a 6-mm glass rod by placing one end of the rod through the center hole. The other end of the rod shall be slightly enlarged to no greater than 10 mm to prevent the specimen from slipping. (**Warning**—The use of a heavy glove is recommended at all times when handling glass rods.)

A1.1.7 Molten solder baths are maintained at different temperatures for each solder type. For Sn30A, dip the specimen sideways

<sup>10</sup> The sole source of supply of the apparatus known to the committee at this time is Industrial Chemical Co. *Low-Corrosive Flux (Acid Bromide)*—a suitable flux, is available from Industrial Chemical Co., Detroit, MI, labeled No. REZ 55-F. Manufacturer’s dilution recommendations should be followed. If you are aware of alternative suppliers, please provide this information to ASTM International Headquarters. Your comments will receive careful consideration at a meeting of the responsible technical committee,<sup>1</sup> which you may attend.