

ISO

INTERNATIONAL ORGANIZATION FOR STANDARDIZATION

ISO RECOMMENDATION R 730

THREE-POINT LINKAGE OF AGRICULTURAL WHEELED TRACTORS
FOR ATTACHMENT OF MOUNTED IMPLEMENTS

1st EDITION
May 1968

COPYRIGHT RESERVED

The copyright of ISO Recommendations and ISO Standards belongs to ISO Member Bodies. Reproduction of these documents, in any country, may be authorized therefore only by the national standards organization of that country, being a member of ISO.

For each individual country the only valid standard is the national standard of that country.

Printed in Switzerland

Also issued in French and Russian. Copies to be obtained through the national standards organizations.

BRIEF HISTORY

The ISO Recommendation R 730, *Three-point linkage of agricultural wheeled tractors for attachment of mounted implements*, was drawn up by Technical Committee ISO/TC 22, *Automobiles (Section ISO/TC 22(T) – Agricultural Tractors)*, the Secretariat of which is held by the Association Française de Normalisation (AFNOR).

Work on this question by the Technical Committee began in 1954 and led, in 1962, to the adoption of a Draft ISO Recommendation.

In December 1965, this Draft ISO Recommendation (No. 876) was circulated to all the ISO Member Bodies for enquiry. It was approved, subject to a few modifications of an editorial nature, by the following Member Bodies :

Australia	France	Sweden
Austria	Hungary	Switzerland
Belgium	Israel	Turkey
Brazil	Italy	U.A.R.
Bulgaria	Japan	United Kingdom
Canada	Netherlands	U.S.A.
Chile	New Zealand	Yugoslavia
Czechoslovakia	Poland	
Finland	Spain	

Three Member Bodies opposed the approval of the Draft :

Germany
Portugal
U.S.S.R.

The Draft ISO Recommendation was then submitted by correspondence to the ISO Council which decided, in May 1968, to accept it as an ISO RECOMMENDATION.

THREE-POINT LINKAGE OF AGRICULTURAL WHEELED TRACTORS FOR ATTACHMENT OF MOUNTED IMPLEMENTS

1. SCOPE

This ISO Recommendation covers requirements for the attachment of implements or equipment to the rear of agricultural wheeled tractors by means of a three-link hitch in association with a power lift.

2. FIELD OF APPLICATION

Two categories of dimensions are specified, the recommended use of each being distinguished according to the drawbar pull during the first five hour test specified by the test code for tractors (drawbar tests at 75 % of the pull corresponding to maximum drawbar power, in the gear selected).

Category 1 : only intended for *light-medium* wheeled tractors, i.e. tractors showing a test result of up to 1150 kgf (2500 lbf), that is 1125 daN, drawbar pull.

Category 2 : intended for *medium-heavy* wheeled tractors, i.e. tractors showing a test result of more than 1150 kgf (2500 lbf), that is 1125 daN, drawbar pull.

3. DEFINITIONS OF TERMS

3.1 General

- 3.1.1 *Linkage*. Combination of one upper link and two lower links, each articulated to the tractor and the implement at opposite ends, in order to connect the implement to the tractor.
- 3.1.2 *Hitch point*. Articulated connection between a link and the implement; for geometrical purposes the hitch point is the centre of the articulated connection between a link and the implement.
- 3.1.3 *Link point*. Articulated connection between a link and the tractor; for geometrical purposes the link point is the centre of the articulated connection between a link and the tractor.

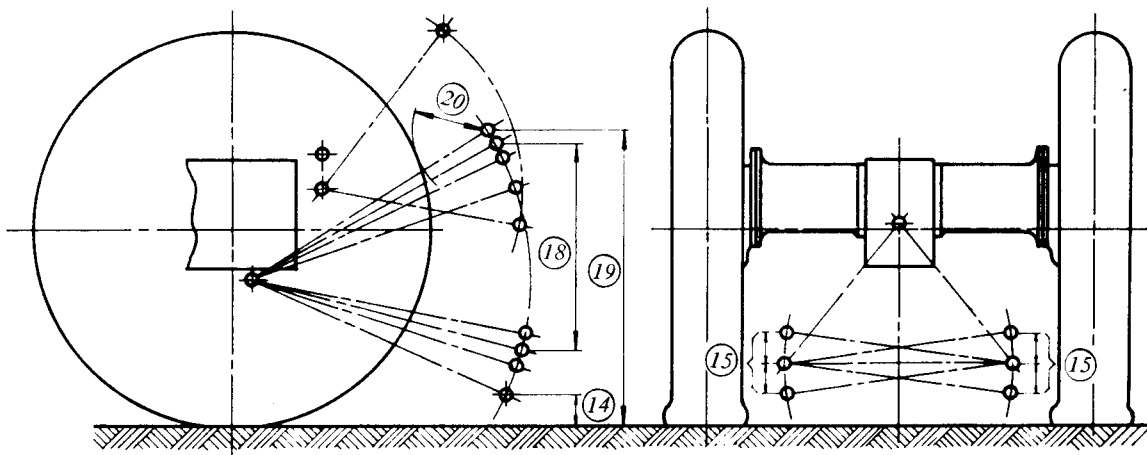
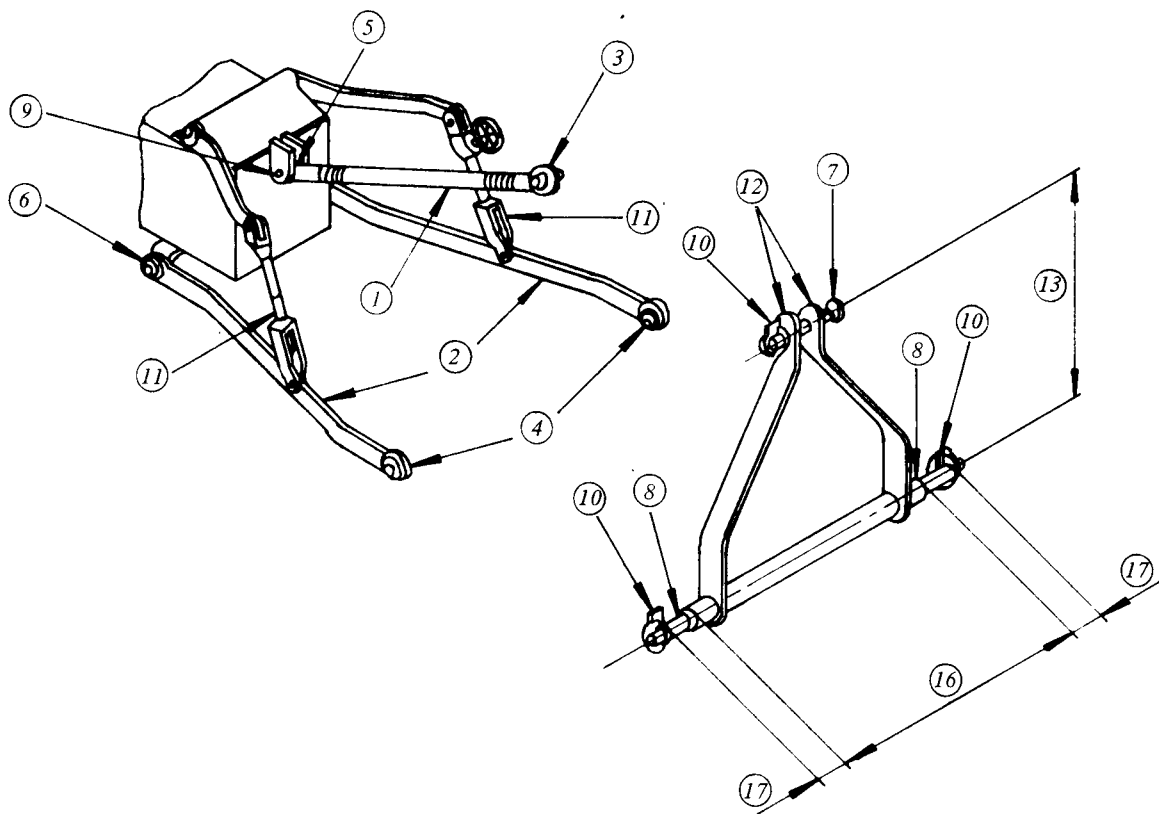

FIG. 1 - Components and dimensional characteristics of three-point linkage
(See clauses 3.2 and 3.3)

3.2 Components of the linkage

The numbers given hereunder refer to Figure 1.

- | | | |
|--|---|---|
| <ol style="list-style-type: none"> 1. <i>Upper link</i> 2. <i>Lower link</i> | } | Elements of the linkage, each fitted with an articulated connection at both ends. |
|--|---|---|
3. *Upper hitch point*. Articulated connection between the upper link and the implement.
 4. *Lower hitch point*. Articulated connection between a lower link and the implement.
 5. *Upper link point*. Articulated connection between the upper link and the tractor.
 6. *Lower link point*. Articulated connection between a lower link and the tractor.
 7. *Upper hitch pin*. Pin, usually detachable and forming part of the upper link assembly, by which the upper link is connected to the implement.
 8. *Lower hitch pin*. Pin, usually attached rigidly to the implement, on which a lower link is secured.
 9. *Upper link pin*. Pin by which the upper link is connected to the tractor.
 10. *Cotter pin*. Pin, usually fitted with a spring retaining device, by which an articulated connection is retained in position.
 11. *Lift rods*. Connections that transmit force to the lower links for raising and lowering.
 12. *Mast*. Component that provides location of the upper hitch point on the implement.

3.3 Dimensional characteristics of the linkage

The numbers given hereunder refer to Figure 1.

13. *Mast height*. Vertical distance between the upper hitch point and the common axis of the lower hitch points.
14. *Lower hitch points height*. Height of the centre of the lower hitch points above ground level when they are in the fully lowered position.
15. *Levelling adjustment range*. Movement, measured vertically, of one lower hitch point higher or lower than the other, to provide an inclination of the implement.
16. *Lower hitch point span*. Distance between the shoulders of the lower hitch pins against which the sides of the lower link ball joints abut.
17. *Cotter-hole distance*. Distance from the centre line of the cotter-hole to the shoulder of the hitch pin.
18. *Power range*. Total vertical movement of the lower hitch points corresponding to the power travel of the lift, excluding any adjustment in the linkage or lift rods.

19. *Transport height.* Height of the lower hitch points above the ground utilizing the full extent of manual adjustment provided in the lift rods in conjunction with the power range, the lower hitch point axis being maintained horizontal to the ground in a transverse plane.
20. *Lower hitch point clearance.* Clearance expressed as a radial dimension from a lower hitch point to the outside diameter of the tyre, mudguard or other part of the tractor, measured in a longitudinal vertical plane with the implement in the raised position and all side sway removed from the links.
- Implement to tractor clearance.* Horizontal dimension, in the area between the two lower links, between the rearmost parts of the tractor and the horizontal line through the two lower hitch points, throughout the range of vertical movement of the hitch points.
21. *Mast adjustment.** Usable range of movement of the mast in a vertical plane. It is measured as the maximum and minimum heights of the lower hitch points above the ground between which a mast of height 460 mm (18 in) can be adjusted to any inclination between the vertical and 10° to the vertical towards the rear.

4. DIMENSIONS**

4.1 Dimensions of hitch points

Dimensions concerning the hitch points are specified in Table 1 and are shown in Figure 2.

NOTE. — The dimensions *A* to *K* and *S* given for category 2 are recommended also for future developments and designs of category 1 tractors.

4.2 Lift, power lift, and adjustment ranges

Ranges of lift, power and levelling adjustment are specified in Table 2 and are shown in Figure 3.

NOTE. — In order to assist in adapting implements or other pieces of mounted equipment for use with different sizes of tractor in the most convenient way, alternative dimensions for the *lower hitch point span* are given. Either of these may be adopted, or provision may be made in the design of the lower links, or by the use of double-ended hitch points, to enable designs based on the dimensions of category 1 to be fitted to designs made in accordance with category 2, or *vice versa*.

4.3 Other dimensions concerning the zone around the hitch points

Dimensions *S* and *T* in Table 1 are shown in Figure 4.

* Adjustment of the mast controls the pitch of the implement. Specifying the mast adjustment to be provided enables the tractor designer to determine the minimum acceptable adjustment of the length of the top link in relation to the points of attachment of the linkage; it also permits the implement designer to determine the range of operating depths of the implement over which pitch adjustment can be obtained.

** Dimensions are based on the assumption that the tractor manufacturer's normal wheel equipment is fitted.

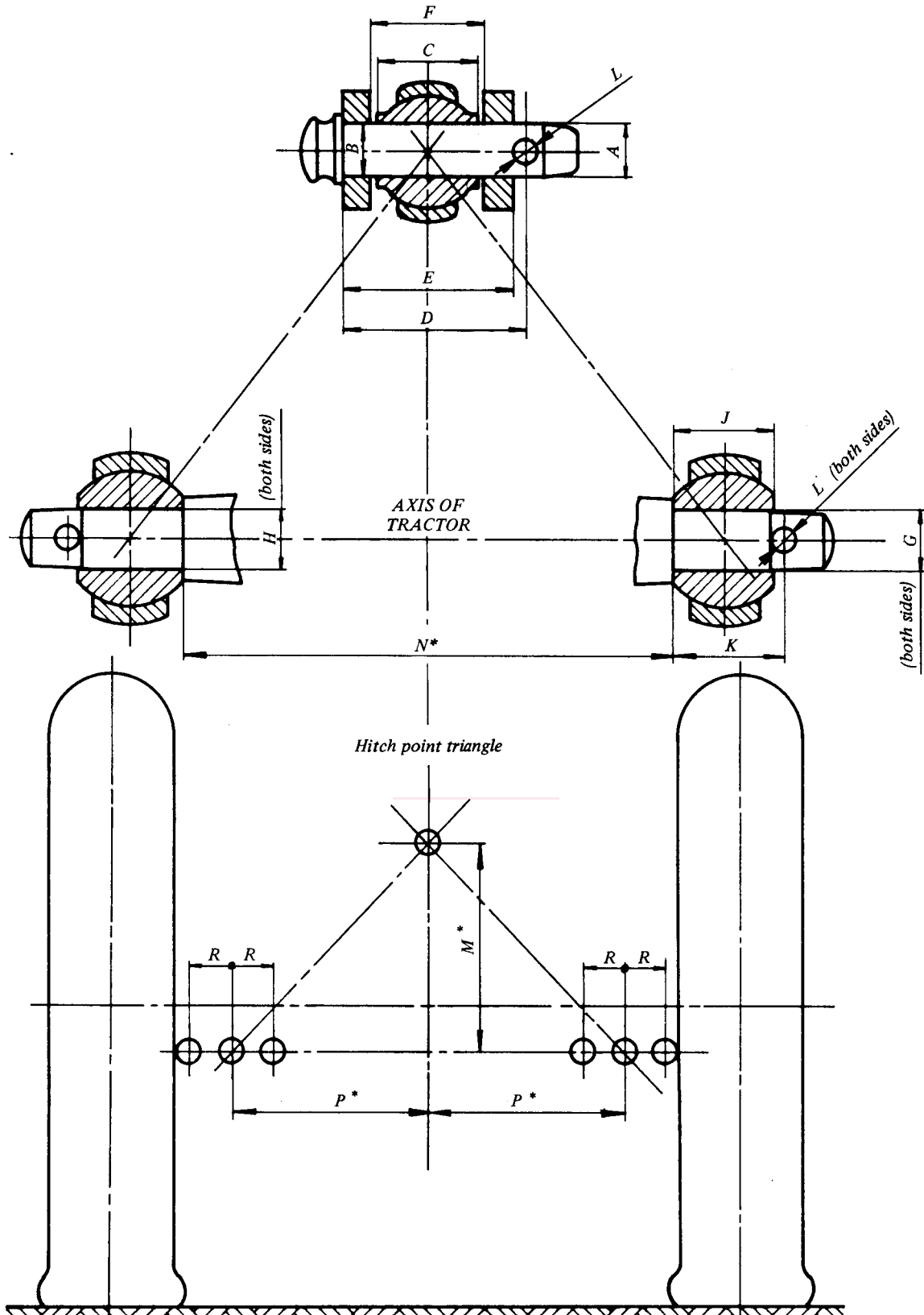

* Recommended dimensions. It may be necessary to vary these dimensions in the case of specialized implements.

FIG. 2 - Dimensions of hitch points
(Category 1 and 2)

TABLE 1 – Dimensions of hitch points

Fig. 2	Dimensional characteristics	Category 1				Category 2			
		millimetres		inches		millimetres		inches	
		min.	max.	min.	max.	min.	max.	min.	max.
	<i>Upper hitch points</i>								
<i>A</i>	Diameter of hitch pin	18.916	19	0.745	0.750	25.27	25.4	0.995	1.000
<i>B</i>	Diameter of hitch pin hole	19.3	19.51	0.760	0.770	25.7	25.91	1.010	1.020
<i>C</i>	Width of ball	—	44	—	1.730	—	51	—	2.010
<i>D</i>	Cotter-hole distance	76	—	3.000	—	93	—	3.640	—
<i>E</i>	Width between outer faces of yoke	—	69	—	2.730	—	86	—	3.370
<i>F</i>	Width between inner faces of yoke	44.5	—	1.750	—	52	—	2.060	—
	<i>Lower hitch points</i>								
<i>G</i>	Diameter of hitch pin	21.79	22	0.860	0.870	27.79	28	1.105	1.115
<i>H</i>	Diameter of hitch pin hole	22.4	22.73	0.885	0.895	28.7	29.03	1.135	1.145
<i>J</i>	Width of ball	34.8	35.0	1.370	1.380	44.80	45.0	1.750	1.760
<i>K</i>	Cotter-hole distance*	39	—	1.530	—	49	—	1.910	—
	<i>Cotter-hole</i>								
<i>L</i>	Diameter of cotter-hole common to upper and lower hitch pins	12	—	15/32 drill	—	12	—	15/32 drill	—
<i>M</i>	Mast height	460** (min.)		18** (min.)		460** (min.)		18** (min.)	
<i>N</i>	Lower hitch point span	683 ± 1.5**		26 7/8 ± 1/16**		825 ± 1.5**		32 7/16 ± 1/16**	
<i>P</i>	Lateral distance from lower hitch point to centre line of tractor	359**		14 1/8**		435**		17 3/32**	
<i>R</i>	Lateral movement of lower hitch point	100 (min.)		4 (min.)		125 (min.)		5 (min.)	
Fig. 4		min.	max.	min.	max.	min.	max.	min.	max.
<i>S</i>	Zone of clearance around each hitch point — spherical radius	45	—	1.77	—	55	—	2.17	—
<i>T</i>	Distance from end of power take-off to centre of lower hitch point. Lower link in horizontal position.	500	575	20	23.0	500	575	20	23.0

* When lateral stays picking up on the lower hitch point holes are employed to limit side sway of the implement, the minimum dimensions should be

for category 1 : 51 mm = 2.000 in
for category 2 : 61 mm = 2.440 in

** Recommended dimensions. It may be necessary to vary these dimensions in the case of specialized implements.

NOTE. — The dimensions *A* to *K* and *S* given for category 2 are recommended also for future developments and designs of category 1 tractors.

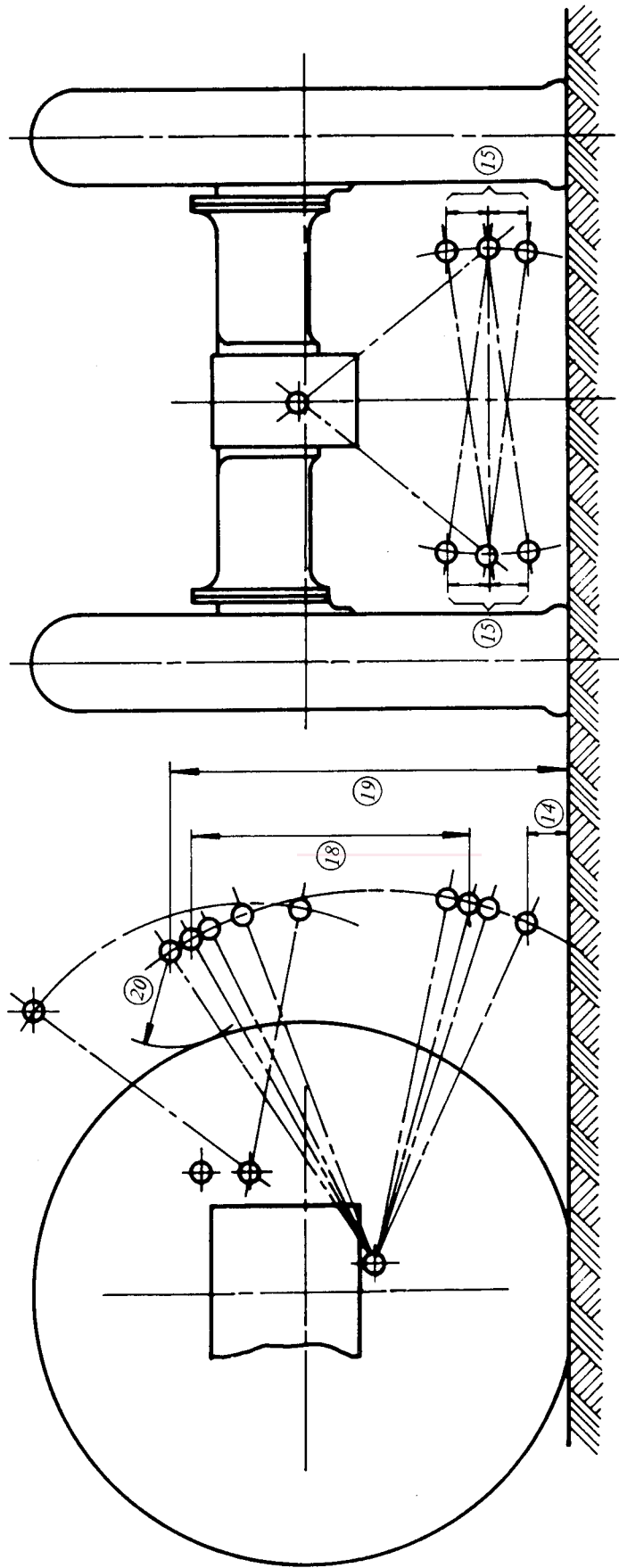

FIG. 3 - Lift, power lift, and adjustment ranges
(Category 1 and 2)

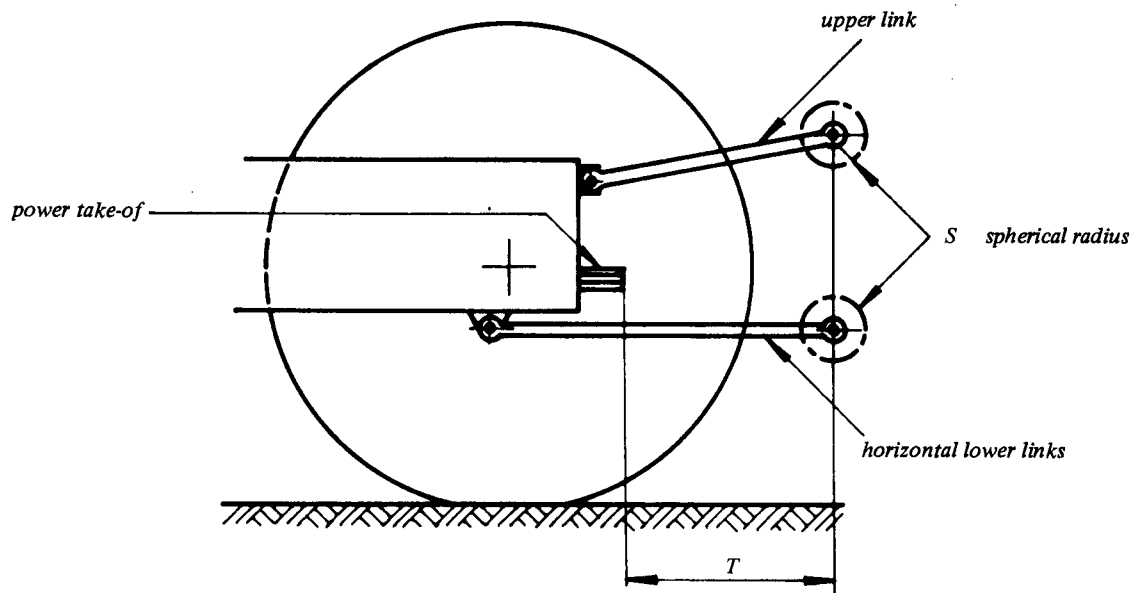

FIG. 4 – Relation between power take-off and rear hitch points.
Zones of clearance around hitch points.