



Designation: **D7833—14 D7833 – 20**

Standard Test Method for Determination of Hydrocarbons and Non-Hydrocarbon Gases in Gaseous Mixtures by Gas Chromatography¹

This standard is issued under the fixed designation D7833; the number immediately following the designation indicates the year of original adoption or, in the case of revision, the year of last revision. A number in parentheses indicates the year of last reapproval. A superscript epsilon (ϵ) indicates an editorial change since the last revision or reapproval.

1. Scope

1.1 This test method is intended to quantitatively determine the non-condensed hydrocarbon gases with carbon numbers from C_1 to C_5+ and non-hydrocarbon gases, such as H_2 , CO_2 , O_2 , N_2 , and CO , in gaseous samples. This test method is a companion standard test method to Test Method [D1945](#) and Practice [D1946](#),² differing in that it incorporates use of capillary columns instead of packed columns and allows other technological differences.

1.2 Hydrogen sulfide can be detected but may not be accurately determined by this procedure due to loss in sample containers or sample lines and possible reactions unless special precautions are taken.

1.3 Non-hydrocarbon gases have a lower detection limit in the concentration range of 0.03 to 100 mole percent using a thermal conductivity detector (~~FCD~~)(TCD), and C_1 to C_6 hydrocarbons have a lower detection limit in the range of 0.005 to 100 mole percent using a flame ionization detector (FID); using a TCD may increase the lower detection limit to approximately 0.03 mole percent.

1.3.1 Hydrocarbon detection limits can be reduced with the use of pre-concentration techniques ~~and/or cryogenic trapping or cryogenic trapping, or both.~~

1.4 This test method does not fully determine individual hydrocarbons heavier than benzene, which are grouped together as C_{7+} . When detailed analysis is not required, the compounds with carbon number greater than C_5 may be grouped as either $C_{6+,}$ or C_{7+} . Accurate analysis of C_5+ components depends on proper vaporization of these compounds during sampling at process unit sources as well as in the sample introduction into the analyzer in the laboratory.

1.5 Water vapor may interfere with the C_6+ analysis if a TCD detector is used.

1.6 Helium and argon may interfere with the determination of hydrogen and oxygen respectively. Depending on the analyzer used, pentenes, if present, may either be separated or grouped with the C_6+ components.

1.7 Units—The values stated in SI units are to be regarded as standard. No other units of measurement are included in this standard.

1.8 *This standard does not purport to address all of the safety concerns, if any, associated with its use. It is the responsibility of the user of this standard to establish appropriate ~~safety~~ safety, health, and ~~health~~ environmental practices and determine the applicability of regulatory limitations prior to use.*

1.9 *This international standard was developed in accordance with internationally recognized principles on standardization established in the Decision on Principles for the Development of International Standards, Guides and Recommendations issued by the World Trade Organization Technical Barriers to Trade (TBT) Committee.*

2. Referenced Documents

2.1 *ASTM Standards:*²

[D1945 Test Method for Analysis of Natural Gas by Gas Chromatography](#)

[D1946 Practice for Analysis of Reformed Gas by Gas Chromatography](#)

[D3588 Practice for Calculating Heat Value, Compressibility Factor, and Relative Density of Gaseous Fuels](#)

¹ This test method is under the jurisdiction of ASTM Committee [D03](#) on Gaseous Fuels and is the direct responsibility of Subcommittee [D03.07](#) on Analysis of Chemical Composition of Gaseous Fuels.

Current edition approved ~~June 1, 2014~~ June 1, 2020. Published ~~June 2014~~ June 2020. Originally approved in 2012. Last previous edition approved in ~~2012~~ 2014 as [D7833D7833 – 14, 12](#); DOI: [10.1520/D7833-14.10.1520/D7833-20](#).

² For referenced ASTM standards, visit the ASTM website, [www.astm.org](#), or contact ASTM Customer Service at [service@astm.org](#). For *Annual Book of ASTM Standards* volume information, refer to the standard's Document Summary page on the ASTM website.

[E355 Practice for Gas Chromatography Terms and Relationships](#)

[E1510 Practice for Installing Fused Silica Open Tubular Capillary Columns in Gas Chromatographs](#)

[F307 Practice for Sampling Pressurized Gas for Gas Analysis](#)

2.2 *ASTM Publication*.³

[ASTM DS 4B, 1991 Physical Constants of Hydrocarbon and Non-Hydrocarbon Compounds](#)

2.3 *Other Document*.⁴

[API MPMS 14.1 Manual of Petroleum Measurement Standards Chapter 14-Natural Gas Fluids Measurement Section 1-Collecting and Handling of Natural Gas Samples for Custody Transfer](#)

3. Terminology

3.1 Terminology related to the practice of gas chromatography can be found in Practice [E355](#).

3.2 *Definitions*:

3.2.1 *sample set*—*set, n*—a collection of samples taken from the same source or at similar component composition and concentrations.

4. Summary of Test Method

4.1 Components in a representative sample are physically separated by gas chromatography (GC) and compared to calibration data obtained under identical operating conditions from a reference standard mixture of known composition. The numerous heavy-end components of a sample can be grouped into irregular peaks by reversing the direction of the carrier gas through the column at such time as to group the heavy ends either as C₅ and heavier, C₆ and heavier, or C₇ and heavier or alternatively elute them in the non-backflushed mode and summed accordingly. The composition of the sample is calculated by comparing the peak areas with the corresponding values obtained with the reference standard.

5. Significance and Use

5.1 The hydrocarbon component distribution of gaseous mixtures is often required for end-use sale of this material. Applications such as chemical feedstock or fuel require precise compositional data to ensure uniform quality. Trace amounts of some hydrocarbon impurities in these materials can have adverse effects on their use and processing. Certain regulations may require use of such method.

5.2 The component distribution data of gaseous mixtures can be used to calculate physical properties such as relative density, vapor pressure, and heating value calculations found in Practice [D3588](#). Precision and accuracy of compositional data is extremely important when this data is used to calculate various properties of petroleum products.

6. Apparatus

ASTM D7833-20

6.1 *Gas Chromatograph (GC)*—This method allows the use of most gas chromatographic analyzers designed for gas analysis. Generally, any gas chromatographic instrument with a linear temperature programmable column oven or adequate temperature control to provide the required separation of gaseous compounds being analyzed may be used. The temperature control must be capable of obtaining retention time repeatability within 5% of the retention time for each component throughout the scope of this analysis for hydrocarbon and non-hydrocarbon gas analyses.

6.1.1 *Detector*—The type and number of detectors employed is dependent on gas analyzer model and vendor used. Detectors that can be used include, but are not limited to FID, TCD, AED (Atomic Emission Detector), HID (Helium Ionization Detector), and MS (Mass Spectrometer). Many systems use a 3 detector system:

(1) One FID (Flame Ionization Detector) for the determination of the hydrocarbon gases for the compounds listed in [Table 1](#),

(2) One TCD (Thermal Conductivity Detector) dedicated to the determination of hydrogen utilizing nitrogen or argon as a carrier gas, and

(3) One TCD for the determination of all other required non-hydrocarbon gases using helium as the carrier gas.

6.1.2 A TCD may also be used for the analysis of the hydrocarbon gases (replacing the FID) when high sensitivity (≤ 0.03 (< 0.03 mole percent) for trace analysis is not required.

6.1.3 Other detectors or combination of detectors may be used provided that they have sufficient response, linearity, and sensitivity to measure the components of interest at the concentration levels required for this application and meeting all of the quality controls specified in this method. Some analyzers, such as micro-analyzers, may contain up to 4-channels and separation systems to accomplish the analysis described in this method.

6.2 *Data Acquisition*—Any commercial computerized data acquisition system may be used for display of the chromatographic detector signal and peak area integration from all of the detectors used in the analysis. The device should be capable of generating and storing a calibration and reporting the final corrected response factor results.

³ Available from the ASTM website, www.astm.org, or contact ASTM Customer Service at service@astm.org

⁴ Available from IHS, 15 Inverness Way East, Englewood, CO 80112, <http://www.global.ihs.com>.

TABLE 1 List of Components Typically Analyzed

Component	FID	TCD
C ₅ olefin / C ₆ + composite	X	X
oxygen/argon composite		X
hydrogen		X
carbon dioxide		X
hydrogen sulfide		X
nitrogen		X
carbon monoxide		X
methane	X	X
ethane	X	X
ethylene	X	X
propane	X	X
propylene	X	X
acetylene	X	X
isobutane	X	X
propadiene	X	X
n-butane	X	X
trans-2-butene	X	X
1-butene	X	X
isobutylene	X	X
cis-2-butene	X	X
neopentane	X	X
cyclopentane	X	X
isopentane	X	X
methyl acetylene	X	X
n-pentane	X	X
1,3-butadiene	X	X

6.3 Sample Introduction and System Configurations—Sample introduction is typically performed with automated valves containing sampling ‘loops’ of appropriate sizes. Fig. 1 gives a suggested configuration, although systems may vary slightly among gas analyzers. The combination of valve injection size and/or splitting inlet ratio, or both, must be selected such that the required sensitivity for the application is achieved and also that no component concentration in a sample is greater than the detector upper linearity limit. The sample inlet system shall be constructed of materials that are inert and non-adsorptive with respect to the components in the sample. The preferred material of construction is stainless steel. Copper, brass, and other copper-bearing

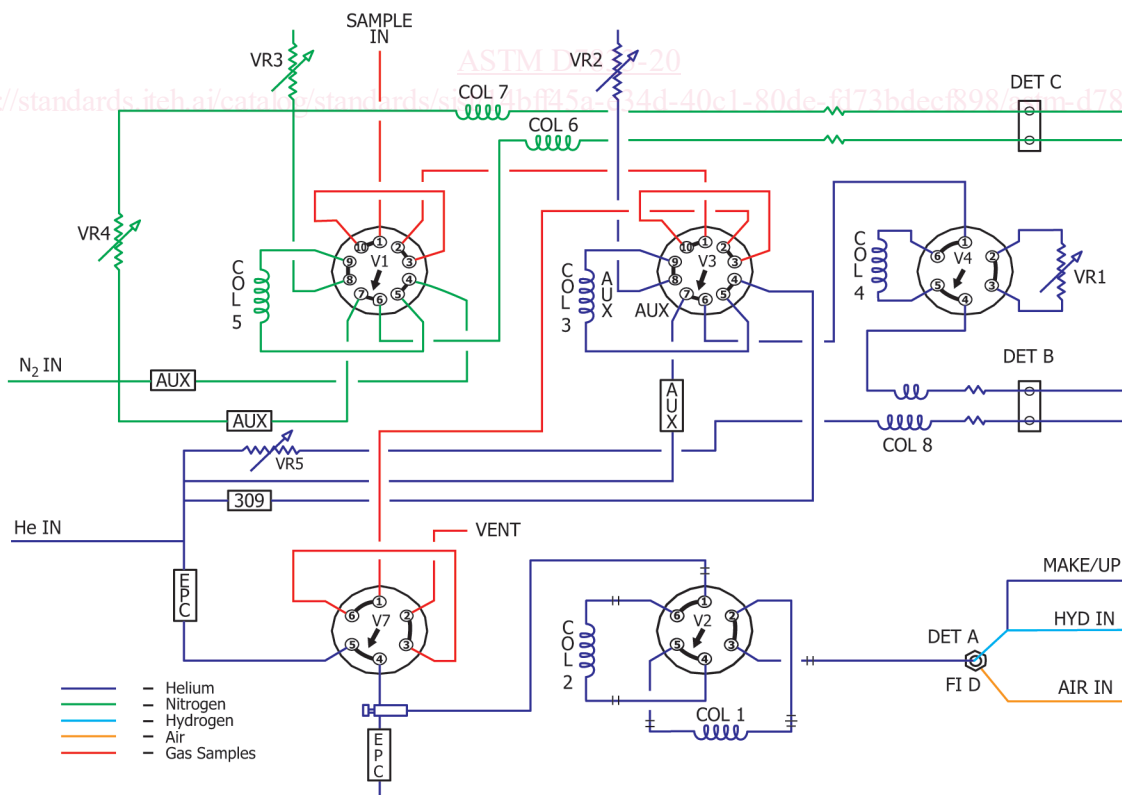

FIG. 1 Example of a Three Detector System for Analysis of Hydrocarbons and Non-Hydrocarbon Gases

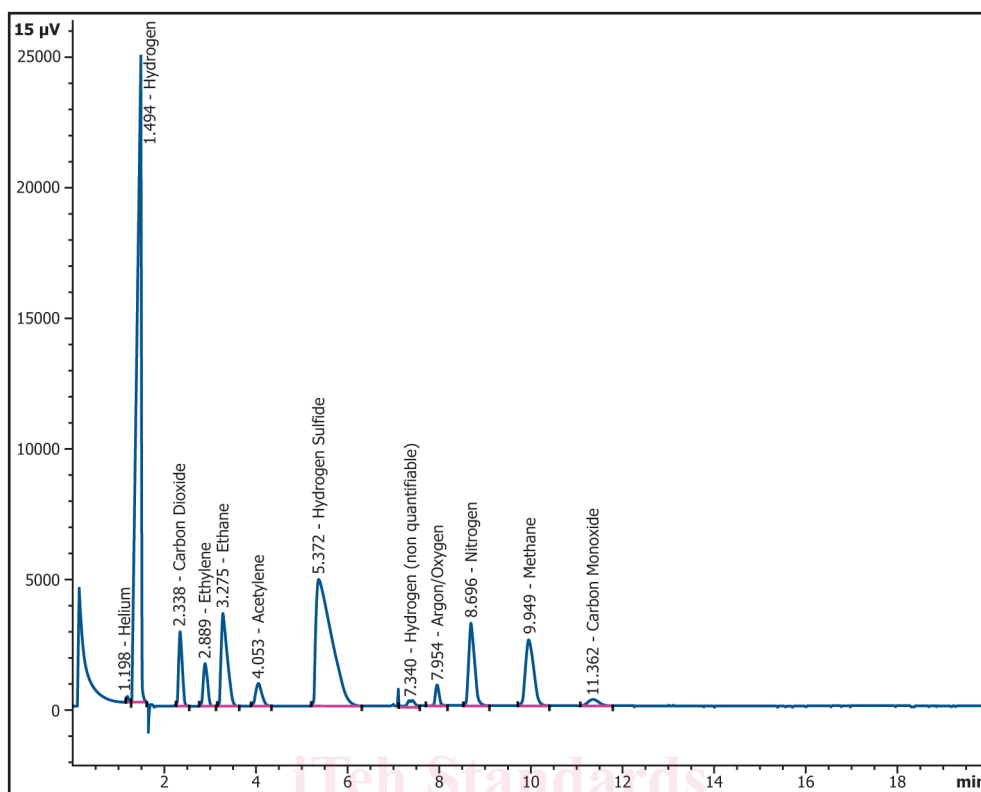

FIG. 2 Example Chromatogram of Non-Hydrocarbon and Light Hydrocarbon Gases from System Configuration in Fig. 1

alloys are unacceptable. The sample size limitation of 0.5 mL or smaller is selected relative to the linearity of the detector response, and efficiency of column separation. Larger samples may be used to determine low-quantity components to increase measurement accuracy. Sample sizes may be determined by experimentation or as recommended by analyzer vendors.

6.3.1 *Hydrogen Sulfide and Other Reactive Gases*—Samples containing hydrogen sulfide and trace reactive gases may benefit from use of surface treated metal surfaces, such as Silcosteel⁵ or Sulfinert⁶ processes. Such specially treated surfaces are also recommended for sample containers that may contain such reactive species.

6.3.2 *With Capillary Columns*—The gas chromatograph must include a heated splitting type inlet that is operated isothermally, or if appropriate, direct connection to the valve may be possible as long as sample sizes are adjusted accordingly, the calibrations are linear in the range of interest, and the required resolution of the compounds of interest is maintained. When using a split injection, split ratios in the range of 5:1 to 200:1, with a typical value of 100:1, have been used successfully depending upon the sample injection volume and sensitivity required.

6.3.3 *With Pre-concentrator and/or Cryogenic Trapping—or Cryogenic Trapping, or Both*—Pre-concentrator and/or cryogenic trapping or cryogenic trapping, or both, can be used prior to sample introduction into the gas chromatograph. These items may enable lower detection limits on the components detailed by the manufacturer to be concentrated.

6.4 *Hydrogen Gas Analysis (Thermal Conductivity Detector)*—A 10-port gas-sampling valve or equivalent may be used with nitrogen or argon carrier gas. Nitrogen or argon carrier gas is used to ensure that the hydrogen ‘peak’ remains positive over the concentration range of interest. Any column or multiple columns may be used, as long as helium and hydrogen are separated and also separated from the other components. Typically, a dedicated TCD is used for this analysis. The gas-sampling valve shall provide a repeatability of at least $\pm 2\%$ relative to the sample volume introduction for major compounds present at >5 vol%.

NOTE 1—When helium is not expected to be present in samples the resolution of hydrogen from helium is not critical.

6.5 *Non-Hydrocarbon and Light Hydrocarbon Gas Analysis (Except Hydrogen) (Thermal Conductivity Detector)*—A 10-port gas sampling valve in combination with a 6-port switching valve or equivalent is used with helium or hydrogen carrier to analyze for CO₂, O₂, N₂, CH₄, C₂H₆, and CO and in some cases H₂S. Any column or multiple columns may be used as long as the desired components are well separated. A TCD may also be used for the analysis of the hydrocarbon gases (replacing the FID) when high sensitivity (<300 ppm) for trace analysis is not required. The gas-sampling valve shall provide a repeatability of at least $\pm 2\%$ relative to the sample volume introduction for major compounds present at >5 vol%.

⁵ Silcosteel is a trademarked has been found satisfactory for this purpose. It is a trademark of SilcoTek, 112 Benner Circle, Bellefonte, PA 16823.

⁶ Sulfinert is a trademarked of Restek Corporation 110 Benner Circle has been found satisfactory for this purpose. It is a trademark of Restek Corporation, 110 Benner Circle, Bellefonte, PA 16823.

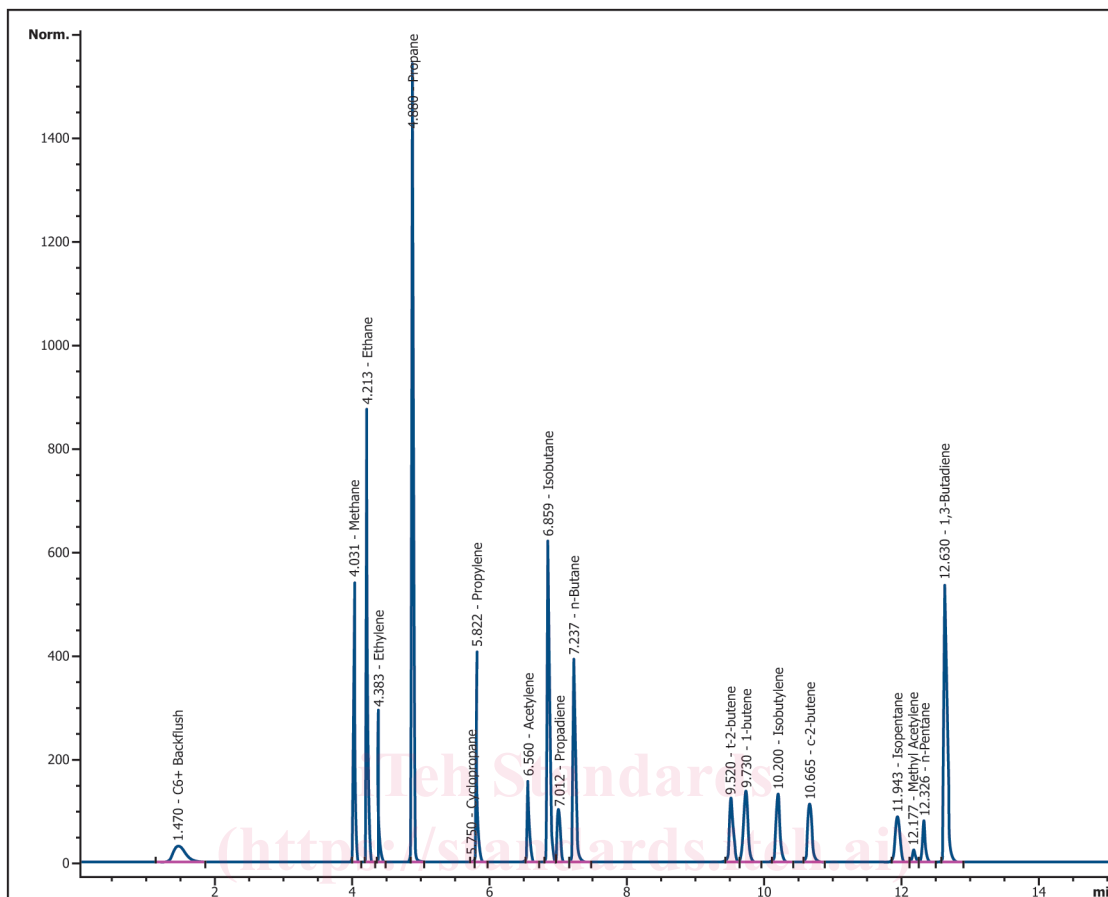

NOTE 1—For the hydrocarbon analysis, the Al₂O₃ PLOT was used.

FIG. 3 Example Chromatogram of Hydrocarbons from System Configuration in Fig. 1

ASTM D7833-20

6.6 *Hydrocarbon Gas Analysis (Flame Ionization Detector)*—A 6-port gas-sampling valve in combination with a 6-port pre-column switching valve (backflush) for the C₆+ or C₇+ hydrocarbons is typically used. These valves shall be contained in a heated enclosure and operated at a sufficiently high temperature, and within the limits of the valve operating temperature as specified by manufacturer, to prevent condensation of the C₆+ components in the sample. The use of a frit or packed-screen type filter ahead of the sample introduction port is recommended with use of PLOT columns. The gas-sampling valve shall provide a repeatability of at least ± 2% relative to the sample volume introduction for major compounds present at >5 vol%.

6.7 *Column Series/Reversal Switching Valve*—If desired, a multi-port valve may be used to provide the C₅ olefin/C₆+ or C₇+ determination for this analysis. Other switching valve configurations may be used to allow the elution of the gaseous compounds. Consult instrument manufacturer for optimum configuration.

NOTE 2—If a dimethylsilicone capillary column or equivalent is used for the hydrocarbon analysis, then the capillary column may be used in the foreflush mode (no-backflush) until all of the hydrocarbons have eluted using temperature programming or equivalent.

6.8 *Gas Controls*—The gas chromatograph shall be provided with suitable facilities for delivery and control of carrier gases and detector gases. This will consist of the appropriate gas supply, down-stream regulators, and supply tubing as well as the mass or pressure controls for the precise regulation of the instrument operation.

NOTE 3—Most gas chromatograph suppliers will provide these devices or recommend the proper suppliers. Ensure that the analyzer, when heated and in-use, does not run out of carrier gases. In addition, running out of carrier gas will require flushing out any air introduced into the sample inlet system, column and/or detector column, or detector, or a combination thereof.

6.9 *Columns*—Condition all columns used according to the manufacturer’s suggestions prior to putting the system in service.

6.10 *Analytical Column for Hydrocarbon Analysis*—A recommended analytical column for the hydrocarbon analysis in Fig. 1 is a 50 m × 0.53 mm (I.D.) deactivated alumina (Al₂O₃) porous layer open tubular (PLOT) column used with a FID detector for lowest detection limits. Relative retention order for the alumina PLOT column is dependent upon the deactivation method for the column and moisture content. **Warning**—Specifically test the alumina PLOT column to ensure that the column does not adsorb propadiene, methyl acetylene, and butadiene when such compounds need to be determined. This condition can exist depending upon the degree of column deactivation. **Caution**—Specifically test the alumina PLOT column to ensure that the column does not

adsorb propadiene, methyl acetylene, and butadiene when such compounds need to be determined. This condition can exist depending upon the degree of column deactivation.

6.10.1 Routine re-conditioning of the alumina PLOT column may be required to maintain column performance. It is recommended that a standby method be used when the system is idle to maintain the PLOT column at a temperature of at least $\pm 30^{\circ}\text{C}$ $\pm 130^{\circ}\text{C}$ or as recommended by the manufacturer.

6.10.2 Alternatively, any column or combination of columns that provides the appropriate component C_1 - C_5 separations may be used.

6.11 *Pre-column for Hydrocarbon Gas Analysis*—When using the alumina PLOT column, if an initial backflush of the C_5 +/ C_6 + components through the use of the sequence reversal/backflush valve is desired, a second column is required. Any pre-column that provides separation between the components of interest and the composite heavier components may be used. Choices may include lengths of column such as a 10 to 30 m section of 0.53 mm (I.D.) ~~3- μm~~ 3 μm film thickness dimethyl polysiloxane or a 9 to 15 cm section of the same column material as the analytical column or any pre-column that provides the desired retention of pentenes, hexanes, and heavier components. This pre-column acts to keep the heavier components away from the analytical alumina PLOT column and to backflush the heavier components as a composite peak to the detector for quantification. If analysis of individual C_6 - C_7 components is required, extend the backflush valve time until the desired components have eluted and prior to backflushing the remaining heavier compounds.

6.12 *Analytical Columns for Hydrogen Analysis*—Generally, hydrogen analysis consists of a pre-column to remove most of the hydrocarbons, H_2S and CO_2 and a Molecular Sieve 5A or equivalent for separation of hydrogen from oxygen and nitrogen. Follow vendor's recommendations.

6.13 *Analytical Columns for Other Non-Hydrocarbon Gases*—Generally, a series-bypass two-valve configuration is used, consisting of porous polymer-molecular sieve 5A or 13X combination. Follow vendor's recommendations.

7. Reagents and Materials

7.1 All chemicals are reagent grade unless specified otherwise, and all water used is distilled or deionized. **Warning**—Hydrogen sulfide contained in calibration standards may be flammable and harmful or fatal if ingested or inhaled. Calibration standards or samples containing hydrogen sulfide should be handled in well ventilated locations away from sparks and flames.

7.2 *Carrier Gases*—For carrier gases, it is strongly recommended to install commercial active oxygen scrubbers and water dryers, such as molecular sieves, ahead of the instrument to protect the chromatographic columns. Follow supplier instructions in the use of such gas purifiers and replace as necessary.

7.2.1 *Chromatographic Grade Hydrogen*, ~~Chromatographic Grade Hydrogen, 99.995% 99.995 %~~ minimum purity, <0.1 ppm H_2O . The use of appropriate scrubbers may be sufficient to obtain the desired purity.

7.2.2 *Chromatographic Grade Helium*, ~~Chromatographic Grade Helium, 99.995 % 99.995 %~~ minimum purity, <0.1 ppm <0.1 ppm H_2O . The use of appropriate scrubbers may be sufficient to obtain the desired purity.

7.2.3 *Chromatographic Grade Nitrogen*, ~~Chromatographic Grade Nitrogen, 99.995 % 99.995 %~~ minimum purity, <0.1 ppm <0.1 ppm H_2O . The use of appropriate scrubbers may be sufficient to obtain the desired purity. **Warning**—Improper handling of compressed gas cylinders containing air, nitrogen, hydrogen, or helium can result in an explosion. Rapid release of nitrogen or helium can result in asphyxiation.

7.3 FID Detector Gases:

7.3.1 *Chromatographic Grade Hydrogen*, ~~Chromatographic Grade Hydrogen, 99.995 %~~ minimum purity. The use of appropriate scrubbers may be sufficient to obtain the desired purity.

7.3.2 *Chromatographic Grade Air*, ~~Chromatographic Grade Air,~~ less than 10 ppm-mol each of total hydrocarbons and water. The use of appropriate scrubbers may be sufficient to obtain the desired purity. **Warning**—Compressed air supports combustion.

7.4 Reference Standards:

7.4.1 *Purity of Reagents*—Reagent grade chemicals shall be used in all tests. Unless otherwise indicated, all reagents should conform to the specifications of the Committee on Analytical Reagents of the American Chemical Society where such specifications are available. Other grades may be used, provided it is first ascertained that the reagent is of sufficiently high purity to permit its use without lessening the accuracy of the determination.

7.4.2 *Calibration Standards*—Individual and mixed component reference materials are commercially available and may be used to establish qualitative and quantitative calibration. The calibration standard mixture should be gravimetrically prepared, supplied with both gravimetric and calculated volumetric and mole% concentrations, and at least NIST traceable or Van Swinden Laboratory, National Metrology Institute of the Netherlands (VSL) certified. The calibration standard mixture should have analytical uncertainty of $\leq 1\%$ $\leq 1\%$ relative.

7.4.3 *Secondary Reference Standards*—A mixture or mixtures of known composition that is (or are) independent of the calibration standards and similar wherever possible in concentration to the samples being analyzed. The secondary reference standards are used as check standards to monitor testing precision and accuracy.

8. Preparation of Apparatus

8.1 Install the valves for the hydrogen, other non-hydrocarbon gases analysis, ~~and/or~~ the hydrocarbon analysis, ~~analysis, or a combination thereof~~. If a turn-key analyzer is used, follow manufacturer's instructions. Fig. 1 gives an example of a three-detector system using the Al₂O₃ column for the hydrocarbons, and individual analyses for hydrogen and other non-hydrocarbon gases.

8.2 If using the alumina PLOT column for the hydrocarbon analysis, it is recommended that the PLOT column undergo routine baking at the maximum method temperature in order to maintain conditioning. See Practice E1510 for recommended installation procedures. If multiple columns for this analysis are placed into the same oven with the alumina PLOT, ensure that the bake out temperature does not exceed the maximum allowable temperature of any of the other columns.

8.3 Set the GC instrument to the operating parameters. Allow the instrument to stabilize before proceeding with calibration and sample injections. When using an alumina PLOT column, recommended operating conditions are listed in Appendix X1. However, conditions may vary if other column systems are used or if tubing is different.

8.4 *Gas Sampling Valves*—Set valve on and off times to comply with manufacturer's instructions. When using a three detector system, sample introduction into the analyzer for hydrogen, non-hydrocarbon gases, and hydrocarbons may be accomplished using valve injections that are synchronized such that samples are injected simultaneously into the system using computer controlled valves. Other sample introduction may be used as long as the repeatability for these systems meets or exceeds those stated in this method. Calibration standards are injected under similar temperature and pressures as the samples to be analyzed. Generally the sampling pressure is approximately atmospheric. The temperature of sampling is such as to avoid condensation of the compounds to be analyzed. For hexanes and higher, heat the sample loop. Most modern chromatographs have valve ovens that can be temperature controlled. It is strongly recommended in the absence of valve ovens to mount the gas-sampling valve in the chromatograph oven and operate at the column temperature. Sub-ambient sampling can be performed if a pressure transducer is used to measure the sampling line pressure and make the appropriate correction.

8.5 *Switching (backflush)(Backflush) Valve for Alumina PLOT Hydrocarbon Analysis (optional)—(Optional)*—The valve rests in the “OFF” state, allowing a continuous backflush flow through the pre-column. Before or upon injection of the sample, the valve should be rotated to the “ON” position so that the pre-column is placed at the head of the flow path from the sample valve (see Fig. 1). At a time which must be empirically determined and which is dependant upon the length and type of pre-column used, the valve must be returned to the “OFF” position, causing the flow to backflush through the pre-column and flush to the detector ahead of components eluting from the analytical column (see Fig. 1). The switch time of the valve should be determined such that the areas of 2-methyl butane, pentane, and 1,3-butadiene are not diminished, but so that pentene components are not allowed to elute to and through the analytical column (where they would elute after the pentanes and 1,3-butadiene). Determining this switch time may require iterative attempts and interpolation. However, once the time has been determined, it should remain repeatable for all samples of similar composition. For other system configurations, consult the analyzer vendor.

<https://standards.iteh.ai/catalog/standards/sist/14bff45a-e34d-40c1-80de-fd73bdecf898/astm-d7833-20>

9. Calibration and Standardization

9.1 *Qualitative*—After the analyzer is installed, at least annually, after major repair, or after extended shutdown, determine the retention times of components by analyzing known reference mixtures in the same manner as samples (Section 11). Table 1 gives a summary of components commonly determined according to this standard using TCD or FID detection. The stated elution order of the hydrocarbons is that for an alumina PLOT column. In general, elution order will vary by column used and the configuration of the analyzer. Note that some PLOT columns do not separate neopentane from butenes.

9.2 *Verification of Linearity*—Ensure that the response of each component of interest is linear bracketing the expected concentration of analytes. Use at least three concentration ranges for each component of interest. This is typically accomplished using a multi-component gas standard(s) containing analytes of interest analyzed with and without dilution or by using gas standards with components at each of the concentrations needed to prepare a calibration curve. Ensure that the linearity regression coefficient is at least 0.999 for each compound calibrated. Special care should be used to verify that low concentration values do not deviate significantly from the calibration curve. If low concentration points do not conform to linearity as defined by higher concentration points, it is necessary to prepare a second calibration curve for low concentration analytes when samples contain components at levels approaching the low level of the initial curve are expected. The linearity is confirmed upon analyzer start-up and whenever major changes are made to the analyzer, such as changing columns, replacing detectors etc. Ensure the TCD analyzing hydrogen exhibits a positive response (peak area) over the range of interest.

9.2.1 *Introduction of Standards*—Open the outlet valve of the sample cylinder and purge the sample through the inlet system and sample loop or tube. The amount of purging required must be established and verified for each instrument.

9.2.1.1 When purging the valve, sample loops, and the general inlet system with calibration standard, do not expose the calibration standards to high flows as this may change the composition of the standard over time. Initiating flows of approximately ~~10–30~~ 10 to 30 mL/min of gas standard should be adequate. Use appropriate regulators on standard cylinders and slowly increase the flow from a zero flow. Once the correct flow has been established, the cylinder regulator may be set to the required setting. The cylinder may be isolated from the system by using the shut-off valve when not in use. The sample loop pressure should be