



Designation: **D7845 – 17 D7845 – 20**

Standard Test Method for Determination of Chemical Species in Marine Fuel Oil by Multidimensional Gas Chromatography/Mass Spectrometry¹

This standard is issued under the fixed designation D7845; the number immediately following the designation indicates the year of original adoption or, in the case of revision, the year of last revision. A number in parentheses indicates the year of last reapproval. A superscript epsilon (ϵ) indicates an editorial change since the last revision or reapproval.

1. Scope*

1.1 This test method covers the quantitative determination of a variety of chemical species in marine fuel oil (bunker fuel oil) by gas chromatography/mass spectrometry. By using the same conditions and by selecting required mass spectral selected ions, the test method may be used for the determination of other species than those for which precision statements and limits of detection have been established.

1.2 An example list of chemical species for which a limit of quantification has been determined by means of this test method is given in **Table 1**.

1.3 Other refinery hydrocarbon fractions and their mixtures may be tested using the same test method conditions. However, the precision of this test method reflects the compounds in **Table 1**.

1.4 Results are reported to the nearest 1.0 mg/kg.

1.5 The values stated in SI units are to be regarded as standard.

1.5.1 *Exception*—Non-SI values are given for psig.

1.6 *This standard does not purport to address all of the safety concerns, if any, associated with its use. It is the responsibility of the user of this standard to establish appropriate safety, health, and environmental practices and determine the applicability of regulatory limitations prior to use.*

1.7 *This international standard was developed in accordance with internationally recognized principles on standardization established in the Decision on Principles for the Development of International Standards, Guides and Recommendations issued by the World Trade Organization Technical Barriers to Trade (TBT) Committee.*

2. Referenced Documents

2.1 ASTM Standards:²

D4307 Practice for Preparation of Liquid Blends for Use as Analytical Standards

¹ This test method is under the jurisdiction of ASTM Committee D02 on Petroleum Products, Liquid Fuels, and Lubricants and is the direct responsibility of Subcommittee D02.04.0M on Mass Spectroscopy/Spectrometry.

Current edition approved Jan. 15, 2017; June 15, 2020. Published February 2017; July 2020. Originally approved in 2013. Last previous edition approved in 2016 as D7845 – 16; D7845 – 17. DOI: 10.1520/D7845-17.10.1520/D7845-20.

² For referenced ASTM standards, visit the ASTM website, www.astm.org, or contact ASTM Customer Service at service@astm.org. For *Annual Book of ASTM Standards* volume information, refer to the standard's Document Summary page on the ASTM website.

*A Summary of Changes section appears at the end of this standard

TABLE 1 Component Table

	Limit of Quantitation mg/kg
n-butyl alcohol	10
Cyclohexanol	10
n-butyl ether	10
n-butyl acrylate	10
Styrene	10
alpha-pinene	10
Phenol	20
alpha-methyl styrene	10
beta-pinene	10
4-methyl styrene	10
trans-B-methyl styrene	10
3-methyl styrene	10
2-methyl styrene	10
Dicyclopentadiene	10
Limonene	10
Indene	20
1-phenyl ethanol	20
para, alpha-Dimethyl styrene	20
2,5 dimethyl styrene	20
2,4 dimethyl styrene	20
2-phenyl ethanol (phenylethanol)	20
2-Ethyl Phenol	50
2,4 Dimethyl Phenol	20
4-Ethyl Phenol (co elutes with 3-ethylphenol)	20
2-Phenoxy-1-propanol	50
2-Phenoxy ethanol	50
4-isopropylphenol	50
1-Phenoxy-2-Propanol	20
Styrene Glycol	50

D6299 Practice for Applying Statistical Quality Assurance and Control Charting Techniques to Evaluate Analytical Measurement System Performance (<https://standards.iteh.ai>)

2.2 Other Standards:

ISO 8217:2010 Petroleum Products—Fuels (Class F)—Specifications of Marine Fuels³

3. Terminology

3.1 Definitions:

3.1.1 *direct or open split interface, n*—any GC/MS interface used to maintain atmospheric pressure at capillary column outlet.

3.1.2 *reconstructed ion chromatogram (RIC), n*—a limited mass chromatogram representing the intensities of ion mass spectrometric currents for only those ions having particular mass to charge ratios used in this test method to selectively extract and identify components in the presence of a complex hydrocarbon matrix.

3.1.3 *total ion chromatogram (TIC), n*—mass spectrometer computer output representing either the summed intensities of all scanned ion currents or a sample of the current in the ion beam for each spectrum scan plotted against the corresponding spectrum number.

3.1.4 *wall coated open tubular (WCOT), n*—a type of capillary column prepared by coating or bonding the inside wall of the capillary with a thin film of stationary phase.

4. Summary of Test Method

4.1 A suitable internal standard, ethylbenzene d-10 is added to the sample, which is then introduced into a gas chromatograph equipped with two columns configured with a Deans switching system between the two columns. The sample first passes through the polydimethylsiloxane (WCOT) pre-column which then performs a separation of the light hydrocarbon fraction and eliminates the high boiling hydrocarbon fraction to vent. The compounds of interest and internal standard are transferred to the high resolution polydimethylsiloxane (WCOT) analytical column for chromatographic separation. An auxiliary carrier gas is used to elute higher boiling hydrocarbons from the pre-column in back flush mode in order to prepare for the next analysis cycle. The resulting chromatogram is then processed by mass spectral analysis based on selected or extracted ion monitoring.

5. Significance and Use

5.1 The test method allows the quantitation of chemical species at low levels in marine fuel oils and cutter stocks. A great many types and concentrations of chemical species are found in marine fuel oils. A root cause relationship between the presence of such

³ Available from American National Standards Institute (ANSI), 25 W. 43rd St., 4th Floor, New York, NY 10036, <http://www.ansi.org>.

species or their concentration in fuels and any failure modes allegedly induced by the use of these fuels has not been established. This test method is necessary to establish test conditions required for future ISO 8217:2010 as defined in section 5.5 and Annex B item (d). Additional compounds may be determined by using the same conditions and by selecting required mass spectral selected ions, accordingly.

6. Apparatus

6.1 Gas Chromatography:

6.1.1 *Gas Chromatograph*—Any gas chromatograph equipped with a flame ionization detector (FID) and having sensitivity of 0.01 mg/kg. The gas chromatograph must be capable of linear temperature control from 50 °C to 320 °C for the capillary column oven. The gas chromatograph must be capable of controlling multiple valve events. Carrier gas flow controllers and or electronic pressure control modules shall be capable of precise control where the required flow rates are low. Pressure control devices and gauges shall be capable of precise control for the typical pressures required. The temperature program rate must repeat to within 0.1 °C and provide retention time repeatability of 0.05 min throughout the temperature program.

6.1.2 *Pre-Column Column*—WCOT Column, 25 m long by 0.53 mm inside diameter fused silica WCOT column with a 1.0 micron film thickness of polydimethyl siloxane or any column with suitable chromatographic resolution.

6.1.3 *Analytical Column*—WCOT Column, 100 m by 0.25 mm inside diameter fused silica WCOT column with a 0.5 micron film thickness of polydimethyl siloxane or any column with suitable chromatographic resolution.

6.1.4 *Purged Packed Injector*—An injection port that allows controlled injection of the sample at a temperature sufficient to pass the high boiling point fraction to the pre-column or any gas chromatographic injector system to perform the same function.

6.1.4.1 The injection port liner shall be replaced to remove non-volatile materials.

6.1.5 *Electronic Pressure Control*—Electronic pneumatic control of carrier gas flows. It can be flow or pressure programmed to speed up elution of components.

6.1.6 *Low-Volume Connector and Tees*—A special union or tee for connecting two lengths of tubing 1.6 mm inside diameter and smaller; sometimes referred to as a zero dead-volume union, tee, or an active splitting device.

6.1.7 *Pre-Column*—A polydimethylsiloxane WCOT column used to isolate the light hydrocarbons to include methane to n-hexadecane from the higher boiling portion of the sample for transfer to the analytical column for further separation and quantification.

6.1.8 *Deans Switching Backflush Configuration*⁴ (Fig. 1)—A column backflush configuration utilizing dynamic pressure differential which provides suitable means to remove the heavier hydrocarbon fraction from the pre-column or any similar configuration that allows for controlled chromatographic separation of components of interest and heavier hydrocarbon fraction. An alternative Deans switching backflush configuration is shown on Fig. 2.

6.2 Mass Spectrometry:

6.2.1 *Mass Spectrometer*, capable of producing electron ionization spectra at 70 electron volts or higher, and capable of scanning the range of the specified quantitation masses or (m/e). The mass scan range shall cover the masses of interest for quantitation and should yield at least 5 scans across the peak width at half peak width for a 1 mg/kg to 3 mg/kg ethylbenzene d10 peak and cover the masses of interest for quantitation. A scan range set for specific ions is defined in Table 2.

6.2.1.1 The mass spectrometer shall be capable of being interfaced to a gas chromatograph and WCOT columns. The interface shall be at a high enough temperature to prevent condensation of components boiling up to 350 °C. Usually, 20 °C above the final column temperature is adequate. Direct column interface to the mass spectrometer may be used. An open split interface with

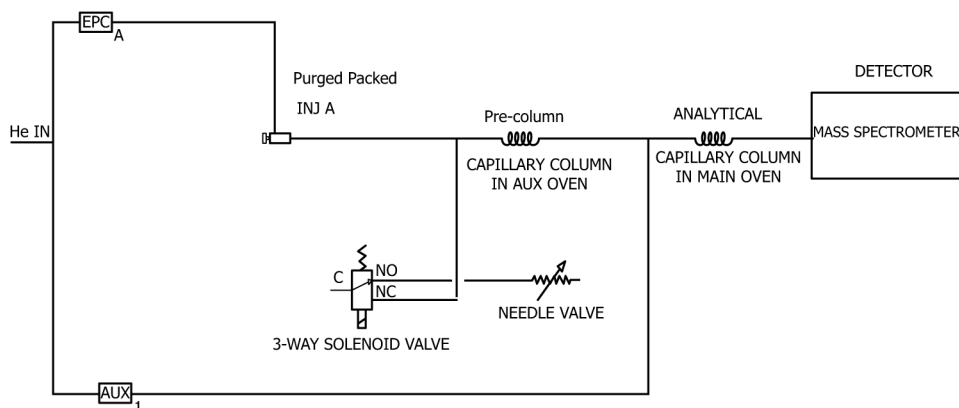

FIG. 1 Deans Switching Backflush, Configuration A

⁴ Deans, D. R., *Chromatographia*, Vol 1, 18-22, 1968.

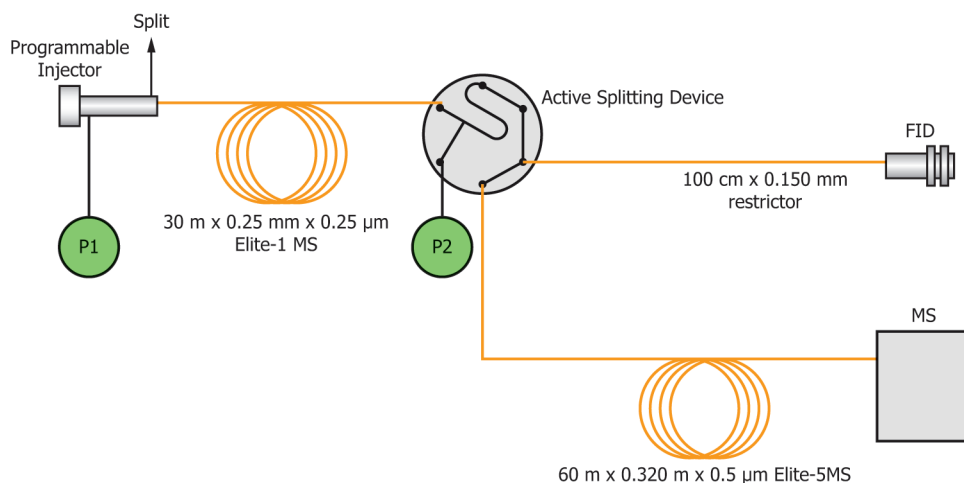

FIG. 2 Deans Switching Backflush, Configuration B

TABLE 2 Mass Spectrometer Compound Quantitation Ions (Retention Time Data Based on Configuration A)

Retention Time	Compound	CAS #	Quantifying	Qualifier 1	Qualifier 2	Qualifier 3
21.55	Ethylbenzene-d10	25837-05-2	116	115		
13.55	n-butyl alcohol	71-36-3	56	74		
22.58	Cyclohexanol	108-93-0	82	100	44	
22.61	n-butyl ether	142-96-1	87	101	130	
22.78	n-butyl acrylate	441-32-2	55	128	73	
22.78	n-butyl acrylate	141-32-2	55	127	73	
23.23	Styrene	100-42-5	104			
26.03	alpha-pinene	80-56-8	93	136	121	
26.66	Phenol	108-95-2	94	66		
27.79	alpha-methyl styrene	98-83-9	118	103		
28.21	beta-pinene	19902-08-0	93	136	121	
28.46	4-methyl styrene	622-97-9	117	118	116	103
28.57	trans-B-methyl styrene	873-66-5	117	118	103	77
28.66	3-methyl styrene	100-80-1	117	118	116	103
29.95	2-methyl styrene	611-15-4	117	118	103	77
30.11	Dicyclopentadiene	77-73-6	66	132		
30.43	Limonene	5989-27-5	68	93	136	121
31.11	Indene	95-13-6	116	115	63	89
31.16	1-phenyl ethanol	98-85-1	107	122	79	
32.93	para, alpha-Dimethyl styrene	1195-32-0	132	117	102	
33.29	2,5 dimethyl styrene	2039-89-6	132	117	77	
33.47	2,4 dimethyl styrene	2234-20-0	132	117	77	
33.57	2-phenyl ethanol (phenylethanol)	60-12-8	122	103	77	
34.05	2-Ethyl Phenol	90-00-6	107	122	77	
34.55	2,4 Dimethyl Phenol	105-67-9	122	107	77	
35.13	4-Ethyl Phenol (co elutes with 3-ethylphenol)	123-07-9	107	122	77	
	3-ethylphenol (co elution)	620-17-7				
35.86	2-Phenoxy-1-propanol	4169-04-4	94	152	121	
37.43	2-Phenoxy ethanol	122-99-6	94	138	77	
37.51	4-isopropylphenol	99-89-8	121	136	94	77
38.53	1-Phenoxy-2-Propanol	770-35-4	94	152	108	77
40.53	Styrene Glycol	93-56-1	107	138	79	

computer controlled programmable flow controller(s) may also be used, to maintain all components within the linearity of the mass spectrometer and at the same time maintain detectability of lower concentration chemical components.

6.2.1.2 Acquisition mode selected ion monitoring (SIM) extracted ion mode or full scan mode using the quantitative and qualitative ions referenced in Table 2. Additional compounds may be added by selecting and collecting data in full scan mode.

6.2.1.3 Tuning shall be performed for low mass resolution using perfluorotributylamine mass fragment ions at m/z 69, 131, and 219 amu. The mass spectrometer is tuned either automatically or manually for optimum performance.

7. Reagents and Materials

7.1 Purity of Reagents—Reagent grade chemicals should be used in all tests. Unless otherwise indicated, it is intended that all reagents conform to the specifications of the Committee on Analytical Reagents of the American Chemical Society where such

specifications are available.⁵ Other grades may be used, provided it is first ascertained that the reagent is of sufficiently high purity to permit its use without lessening the accuracy of the determination.

7.2 *Carrier Gas*—Helium and hydrogen have been used successfully. The recommended minimum purity of the carrier gas used is 99.999 mol %. Additional purification using commercially available scrubbing reagents may be necessary to remove trace oxygen, which may deteriorate the performance of the GC WCOT.

7.3 *Calibration Standard*—This standard shall be prepared by adding the chemicals to include those in **Table 1** prepared from high (99+ %) purity reagent grade materials.

7.4 *Standards for Calibration and Identification*—Chemical compounds used to prepare standards should be 99 % or greater purity (see **Table 1**). If reagents of high purity are not available, an accurate assay of the reagent shall be performed using a properly calibrated GC or other techniques. The concentration of the impurities that overlap the other calibration components shall be known and used to correct the concentration of the calibration components. The use of only high purity reagents is strongly recommended because of the error that may be introduced from impurity corrections. Standards are used for calibration as well as for establishing the identification by retention time in conjunction with mass spectral match.

7.5 *n-hexadecane*—99+ % purity or better.

7.6 *Dilution Solvents*—Reagent grade toluene, 99.9 % (or suitable dilution solvent).

7.7 *Internal Standards*—Deuterated analog of ethylbenzene, as specified, shall be used as internal standard because of the similar chromatographic characteristics as the components analyzed.

TABLE 3 Operating Conditions Configuration A

Gas Chromatograph:			
<i>Inlet Type:</i>	Purged Packed		
<i>Inlet Temperature:</i>	325 °C		
<i>Oven temperature program:</i>	70 °C for 2 min then 2.5 °C/min to 100 °C for 0 min then 4.5 °C/min to 185 °C for 0 min then 65 °C/min to 322 °C for 20 min		
<i>Run Time:</i>	54.997 min		
<i>Columns:</i>	25 m, 0.53 mm ID, 1.0 µm film polydimethylsiloxane (pre-column); 100 m, 0.25 mm ID, 0.5 µm film polydimethylsiloxane (analytical column)		
<i>Carrier gas:</i>	Helium		
<i>Carrier gas:</i>	Purged Packed Inlet Pre-column: 38 psi (262 kPa)		
<i>Carrier gas:</i>	Analytical Column - Auxiliary Pressure Module 1 set at 37 psi (255.1 kPa)		
<i>Auxiliary Oven Temperature:</i>	325 °C		
<i>Valve 1 Timing:</i>	Valve on at 3.5 min		
<i>Needle Valve 1 Flow Setting:</i>	7 mL/min		
<i>GC-MS Interface:</i>	Direct or open split interface		
<i>GC-MS Interface Temperature:</i>	350 °C		
Mass Spectrometer:			
<i>Detector:</i>	Quadrupole mass spectrometer		
<i>MS Data Acquisition Mode:</i>	Selected Ion Mode		
<i>Ionization Voltage:</i>	(eV) 70, fixed operating condition		
<i>Mass Scan Range:</i>	m/z 35-200		
<i>Scan Rate (scan/s):</i>	> 1		
<i>Resolution Setting:</i>	Low		
<i>Ions/Dwell In Group</i>	(Mass, Dwell)	(Mass, Dwell)	(Mass, Dwell)
	(41.00, 50)	(44.00, 50)	(51.00, 50)
	(55.00, 50)	(56.00, 50)	(63.00, 50)
	(66.00, 50)	(68.00, 50)	(73.00, 50)
	(74.00, 50)	(77.00, 50)	(79.00, 50)
	(82.00, 50)	(87.00, 50)	(89.00, 50)
	(91.00, 50)	(93.00, 50)	(94.00, 50)
	(98.00, 50)	(100.00, 50)	(101.00, 50)
	(103.00, 50)	(104.00, 50)	(105.00, 50)
	(107.00, 50)	(108.00, 50)	(116.00, 50)
	(117.00, 50)	(118.00, 50)	(121.00, 50)
	(122.00, 50)	(128.00, 50)	(130.00, 50)
	(132.00, 50)	(136.00, 50)	(138.00, 50)
	(152.00, 50)		
<i>MS Source Temperature:</i>	250 °C		
<i>MS Quad Temperature:</i>	200 °C		

⁵ ACS Reagent Chemicals, Specifications and Procedures for Reagents and Standard-Grade Reference Materials, American Chemical Society, Washington, DC. For suggestions on the testing of reagents not listed by the American Chemical Society, see *Analar Standards for Laboratory Chemicals*, BDH Ltd., Poole, Dorset, U.K., and the *United States Pharmacopeia and National Formulary*, U.S. Pharmacopeial Convention, Inc. (USPC), Rockville, MD.

8. Preparation of Apparatus

8.1 *Assembly*—Configure the GC system in a multidimensional configuration as described in [Table 3](#) and [Table 4](#). Connect the WCOT columns to the chromatographic system, including the multidimensional switching device, using low volume connectors and inert narrow bore tubing. It is important to minimize the volume of the chromatographic system that comes in contact with the sample; otherwise, peak broadening will occur.

8.2 This section provides details to establish the configurations described in [Fig. 1](#). For other column configurations, adjust backflush and or cut times, accordingly.

8.3 It is essential that the appropriate backflush time be determined to prevent heavy contaminants from reaching the analytical column and potentially interfering with the determination of compounds of interest.

8.4 *Setting the Backflush Time for Configuration A*—The pre-column connected to the analytical column and the mass spectrometer as shown in [Fig. 1](#) inject the calibration standard and record the chromatogram. Identify the peaks. The retention time data are used to set the valve on time to assure the compound peaks are not backflushed. The retention times should be incorporated into the software timed events before continuing with sample analysis. Assure all of the compounds of interest are present and high boiling hydrocarbons are backflushed consistently. Assure the retention time data is repeatable. If retention time shifts are encountered check for leaks to include replacing septum and that all column and valve connections are leak free.

8.4.1 The procedure used is as follows:

8.4.1.1 Prepare a timing standard containing all of the compounds of interest.

8.4.1.2 Inject the timing standard into the GC in the foreflush position with no backflush.

8.4.1.3 Analyze the resulting chromatogram and determine the retention time of each of the compound peaks. See [Figs. 3-5](#).

8.4.1.4 Starting at an arbitrary backflush time (4 min is a good starting point) reinject the sample and analyze the chromatogram for the presence of the compound peaks including C16.

8.4.1.5 Reduce the backflush time in 30 s increments and repeat until little or no C16 is visible. There should not be any significant decrease in the highest boiling compound peak area. Record this time as the backflush time. Conversely, if none of the peaks are visible, increase the backflush time in 30 s increments and repeat step (4) until the highest boiling compound peak area is entirely foreflushed into the analytical column.

8.5 *Setting the Backflush Time for Configuration B*—The elution of peaks from the precolumn is monitored by the flame ionization detector. The required backflush time may be established by locating the styrene glycol peak in a chromatogram of the calibration standard and setting the backflush point just after this.

8.5.1 The procedure used is as follows:

8.5.1.1 Prepare a timing standard containing all of the compounds of interest at a nominal concentration of 500 ppm.

8.5.1.2 Inject the timing standard into the GC in the foreflush position with no backflush.

8.5.1.3 Monitor the pre-column chromatogram on the FID and wait until the n-hexadecane solvent has eluted.

8.5.1.4 Analyze the resulting FID chromatogram and determine the retention time of the last eluting analyte, styrene glycol. See [Fig. 6](#).

8.5.1.5 Enter a timed event into the analytical method to reduce the pressure at the injector to 2 psig (13.78 kPa) by a timed event at a time 0.5 min to 1.0 min later than the retention time of styrene glycol as shown in [Fig. 2](#).

TABLE 4 Operating Conditions Configuration B

Gas Chromatograph:	
<i>Inlet Type:</i>	Programmable split/splitless
<i>Inlet Temperature:</i>	200 °C for 14 min, then 200 °C/min to 400 °C, hold until end of run
<i>Oven temperature program:</i>	50 °C for 2 min then 7 °C/min to 200 °C for 0 min
<i>Run Time:</i>	24 min
<i>Columns:</i>	30 m, 0.25 mm ID, 0.25 µm film polydimethylsiloxane (pre-column); 60 m, 0.32 mm ID, 0.5 µm film 5% phenyl/polydimethylsiloxane (analytical column)
<i>Bypass restrictor</i>	2 m × 0.150 µm deactivated fused silica tubing
<i>Carrier gas:</i>	Helium
<i>Carrier gas:</i>	PSS Inlet Pre-column: 38 psig (261 kPa) for 14 min then 2 psig (13.78 kPa) for the remainder of the run
<i>Carrier gas:</i>	Split flow rate 25 mL/min for duration of run
<i>Carrier gas:</i>	Analytical Column - Auxiliary Pressure Module set at 15 psig (103.4 kPa) for the entire run
<i>Mid-point monitor detector:</i>	Flame ionization
Mass Spectrometer:	
<i>GC-MS Interface:</i>	Direct
<i>GC-MS Interface Temperature:</i>	250 °C
<i>Detector:</i>	Quadrupole mass spectrometer
<i>MS Data Acquisition Mode:</i>	Full scan with extracted ion quantification
<i>Ionization Voltage:</i>	(eV) 70 fixed operating condition
<i>Mass Scan Range:</i>	m/z 35-200
<i>Scan Rate (scan/s):</i>	> 1
<i>MS Source Temperature:</i>	250 °C

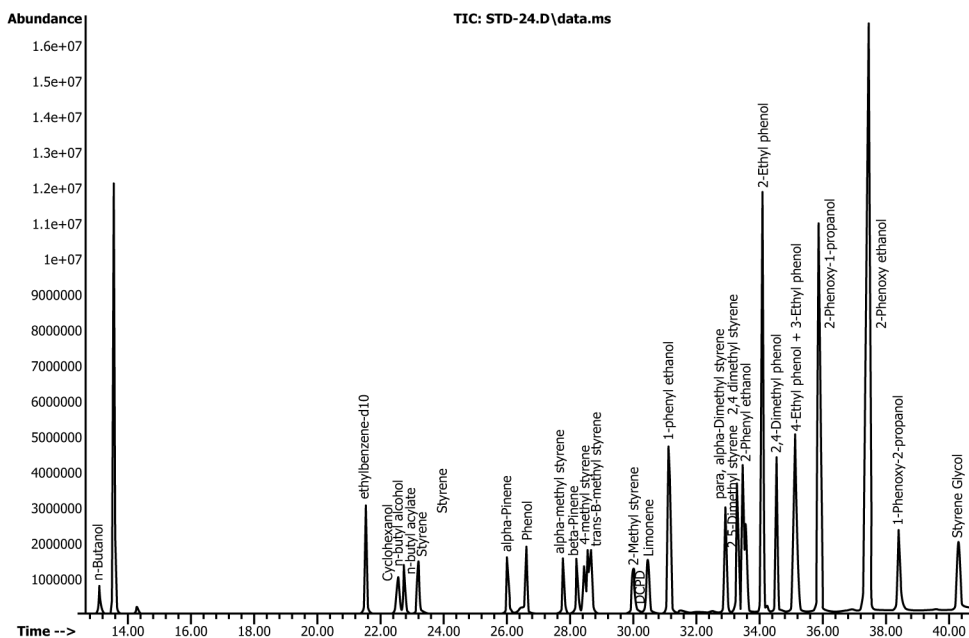

FIG. 3 TIC Chromatogram using Configuration A

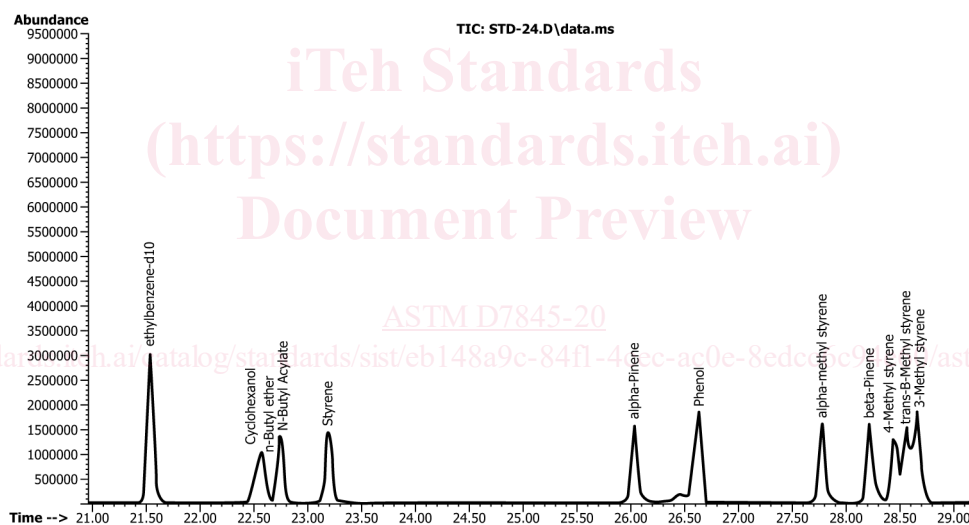

FIG. 4 TIC Chromatogram using Configuration A (21 min – 29 min window)

8.5.1.6 Check operation of the new method by re-injecting the timing mix and confirm that no peaks elute after styrene glycol from both columns.

NOTE 1—Backflush time is dependent upon specific instrument operating conditions, such as flow rate and temperature.

8.6 Replacement of the inlet septum should be performed at least every 10 to 20 injections to reduce the possibility of leaks. Liner replacement should be performed regularly if system performance degrades. The injection port septum purge line should be inspected and cleaned as necessary after 150 injections or when the performance deteriorates based on quality control sample performance data.

9. Calibration

9.1 *Preparation of Calibration Standards*—Prepare multi-component calibration standards using the compounds referenced in Table 5 in toluene based on Test Method D4307.

9.2 Prepare a solution of 1 mg/kg of styrene and verify that it is detected with a signal to noise ratio of at least 5 at mass 104.

9.3 Each component in Table 1 shall be calibrated using a minimum of 5 point calibration curve in the range of approximately 10 mg/kg to 500 mg/kg (or as outlined in Table 5), accordingly.