



Designation: **D6205 – 12 D6205 – 20**

Standard Practice for Calibration of the James Static Coefficient of Friction Machine¹

This standard is issued under the fixed designation D6205; the number immediately following the designation indicates the year of original adoption or, in the case of revision, the year of last revision. A number in parentheses indicates the year of last reapproval. A superscript epsilon (ϵ) indicates an editorial change since the last revision or reapproval.

1. Scope

1.1 This practice covers the testing of the James Machine for repeatability of static coefficient of friction, relative to a standard reference interface consisting of the working surfaces of Borco² board and standard leather shoe sole material, or a control polish film and standard leather shoe material. The practice provides basis data on the stability of the James Machine to ensure accurate static coefficient of friction determinations over time and repeated use and for determining if the James Machine is mechanically calibrated and properly aligned.

1.2 This practice is written specifically for James Machines with manual or motorized test table transport. Variations of this practice for the calibration of versions of James Machines which are semi-automated are obvious. Calibration practices suggested by the manufacturer of semi-automatic James Machines should be followed in preference to this practice.

1.3 *This standard does not purport to address all of the safety concerns, if any, associated with its use. It is the responsibility of the user of this standard to establish appropriate safety, health, and environmental practices and determine the applicability of regulatory limitations prior to use.*

1.4 *This international standard was developed in accordance with internationally recognized principles on standardization established in the Decision on Principles for the Development of International Standards, Guides and Recommendations issued by the World Trade Organization Technical Barriers to Trade (TBT) Committee.*

2. Referenced Documents

2.1 ASTM Standards:³

[D2047 Test Method for Static Coefficient of Friction of Polish-Coated Flooring Surfaces as Measured by the James Machine](#)

[D2825 Terminology Relating to Polishes and Related Materials](#)

[D4103 Practice for Preparation of Substrate Surfaces for Coefficient of Friction Testing](#)

[E29 Practice for Using Significant Digits in Test Data to Determine Conformance with Specifications](#) [astm-d6205-20](#)

[E178 Practice for Dealing With Outlying Observations](#)

2.2 Federal Specification:

[KK-L-165C Leather, Cattlehide, Vegetable Tanned and Chrome Tanned, Impregnated, and Soles](#)⁴

3. Terminology

3.1 *Definitions:* For general definitions, see Test Method [D2047](#) and Terminology [D2825](#).

3.2 *Definitions of Terms Specific to This Standard:*

3.2.1 *Borco, n*—special 5-ply vinyl drawing board cover.

¹ This practice is under the jurisdiction of ASTM Committee [D21](#) on Polishes and is the direct responsibility of Subcommittee [D21.06](#) on Slip Resistance. Current edition approved ~~Oct. 1, 2012~~ June 15, 2020. Published ~~October 2012~~ July 2020. Originally approved in 1998. Last previous edition approved in ~~2006~~ 2012 as D6205- 06; 12. DOI: ~~10.1520/D6205-12.10.1520/D6205-20.~~

² Borco is a registered trademark for a Danish product imported into the United States by Sierra Group, a division of Wallace Leisure Products, Inc. Available from Papyro-Tex A/S, DK-2730, Herlev, Denmark; distributed in North America through drafting and office supply stores under the trade names “Borco,” “Vyco,” and “Altex” board covers.

The sole source of supply of Borco known to the committee at this time is Phipps’s Reprographics 6920 Plainfield Rd, Cincinnati, OH 45236. If you are aware of alternative suppliers, please provide this information to ASTM International Headquarters. Your comments will receive careful consideration at a meeting of the responsible technical committee,¹ which you may attend. See also: <https://www.thehcopa.org/resources/#1517763820809-cf4141f9-4ecb>.

³ For referenced ASTM standards, visit the ASTM website, www.astm.org, or contact ASTM Customer Service at service@astm.org. For *Annual Book of ASTM Standards* volume information, refer to the standard’s Document Summary page on the ASTM website.

⁴ Available from Standardization Documents Order Desk, Bldg 4 Section D, 700 Robbins Ave., Philadelphia, PA 19111-5094, Atten: NPODS.

3.2.2 *Borco/standard leather reference interface, n*—working interface consisting of the white side of the Borco material, mounted as described in this practice, and the standard leather shoe sole material, mounted on a precision shoe pad as described in Section 7 of Test Method **D2047**.

3.2.3 *control polish, n*—a reference polish of known or well established Static Coefficient of Friction, as determined by repeated determinations using Test Method **D2047** over a long period of time and preferably by determinations on multiple James Machines.

3.2.4 *control polish/standard leather reference interface, n*—working interface consisting of a dried film of control polish, applied according to the procedures of Practice **D4103** on standard vinyl composition tile, and the standard leather sole material, mounted on a precision shoe pad as described in Section 7 of Test Method **D2047**.

3.2.5 *standard test sequence, n*—series of not less than eight consecutive Static Coefficient of Friction (SCOF) determinations made on the Borco/standard leather interface or control polish/standard leather interface in accordance with this practice. The arithmetic average and standard deviation of one standard test sequence is the Static Coefficient of Friction (SCOF) of the interface.

4. Summary of Practice

4.1 The performance of the James Machine, in the standard configuration for the determination of Static Coefficient of Friction (SCOF), is tested relative to a standard working interface consisting of the surface of white Borco material in contact with a standard leather shoe pad, or a control polish film in contact with a standard leather shoe pad. The static coefficient of friction values generated provide a basis to establish the repeatability of the mechanical configuration of the James Machine and determine whether the machine remains within the calibration limits.

5. Significance and Use

5.1 This practice is used to calibrate the James Machine for determination of static coefficient of friction of polish surfaces in accordance with Test Method **D2047**. Over considerable time and repeated use the James Machine may tend to mechanical misalignment, giving self-evident, anomalous readings. The periodic accumulation and comparison of data generated by this practice provides an indication of when the machine is no longer within the calibration limits and can no longer be expected to provide accurate and reliable data.

5.2 Semi-automated James machines may perform an internal calibration/alignment test. These automated tests should be routinely run per the manufacturer's recommendation. If the repeatability tests of this practice indicate that the machine is out of calibration, the manufacturer should be contacted and their suggestions followed. Unqualified disassembly, modification, or adjustment may void the instrument warranty of semi-automated James Machines.

6. Interferences (Troubleshooting)

6.1 Deviations in calibration data and anomalies in machine accuracy and repeatability are due to the following interferences:

6.1.1 *Contamination of the Test Surfaces*—These are most commonly due to fingerprints or other soils on the working leather surface or the working surface of the Borco board, or the presence of residual materials on the Borco board from use of an improper cleaning solution. Generally, contamination of the working surfaces will result in low readings.

6.1.2 *Irregular Test Table Transport*—This problem is most common on James Machines that derive test table transport from manual cranking, which may not be smooth and uniform, but it may also be caused by localized wear or grit and dirt in the drive mechanism or on the transport guides of the test table. Test table movement that is not smooth and uniform will provide low readings.

6.1.3 *Improper Rate of Test Table Transport*—Even when uniform, the use of an improper rate of test table transport will result in changes in the readings. This is most often seen in manually cranked test table transports, where the rate of travel is difficult to judge subjectively without training and practice. Many motor driven test tables have an electrical motor speed control to adjust the rate of table travel, and this can be inadvertently changed. Too rapid a rate of travel will result in high readings, and too slow a rate of travel will result in low readings.

6.1.4 *Wear or Binding*—Wear or binding at the following bearing surfaces will result in deviations from calibration and loss of machine repeatability: upper strut pivot, upper strut ball bearings, back plate, strut rack and pinion gear assembly, lower strut pivot, and shoe pad cups for lower strut pivots. These problems are most often the result of the normal, repeated use of the James Machine, but they can also be caused by heavy impacts, improper use, improper or inadequate periodic cleaning and lubrication, or inadequate protection of the machine from dirt. Wear resulting in excessive play in the bearing surfaces will cause lower readings. Sporadic binding of the bearing surfaces and pivot points will result in loss of machine repeatability. Consistent binding of the bearing or pivot surfaces can result in high readings.

6.1.5 *Test Table not Flat*—Test tables are warped out of flatness by heavy impacts onto the table, storage of heavy items on the edges of the test table, or storage of the James Machine with the weight and strut in the upright position resting on the test table. Test table flatness may be assessed visually or by use of a machinist's dial gage attached to the strut rack gear and in contact with the traversing test table. Lack of adequate test table flatness will result in poor repeatability of data as a function of the test specimen (tile) placement on the table.

6.1.6 *Test Table not Level*—This is often due to the entire James machine not being level. Otherwise, this problem is usually caused by wear of the table transport guides, an impact on the table, or improper use of the test table for storage. A test table which

is not level will result in abnormal readings. The deviation from accurate readings will depend on the magnitude and direction of the deviation of the test table from level. After many adjustments are made to level the Test Table, use the machinist's square to ensure that the plane of strut motion is perpendicular to the Test Table.

6.1.7 *Excess Play or Movement in the Strut Rack Gear*—This results from wear in the strut rack and pinion gear assembly, loss of lubricant, or use of an improper lubricant in the gear box. Care must be taken that there is enough freedom in the movement of the strut rack gear so that the vertical motion of the strut rack gear is not impeded. Excess play in any direction perpendicular to the vertical motion of the strut rack gear will result in low readings.

6.1.8 *Test Table Travel is not in the Plane of Strut Motion*—This is usually caused by excessive movement in the strut rack gear assembly so that the plane of strut motion is rotated (see 6.1.7), binding or excessive movement in at least one of the upper strut pivots (see 6.1.4), or wear of the test table transport guides (see 6.1.6). This problem results in low readings, since the slipping motion of the shoe pad on the test surface is compounded by a skewing action (greater lateral forces are applied at the interface than are recorded by the linear table displacement shown on the chart).

6.1.9 *Chart Board (or Chart) is not in a Plane Parallel to the Plane of the Strut Motion*—This problem is usually due to a heavy impact on the chart board, but it can also be due to the use of a pad of charts (rather than an individual sheet) attached to the chart board. The magnitude and sign of deviations in readings that result from this problem depend on the magnitude and direction of the deviation of the chart board from a parallel configuration with respect to the plane of strut motion.

6.1.10 *Warped, or "Out of True" Back Plate, Chart Board, Strut Arm, or Strut Rack Gear*—Though this problem can be the result of heavy impact, it is most commonly the result of not maintaining the James Machine in a controlled temperature environment. The James Machine is a complex assembly of parts that are rigidly held in alignment by bead welds or bolts. Since many of the parts are constructed of different metals, temperature changes (and the different coefficients of thermal expansion) will result in very large forces being applied to the joints or to the components themselves. This can result in a distortion or warping of the parts, particularly those which are large or have at least one long dimension.

7. Apparatus

7.1 *James Machine*^{5,6}—See Fig. 1.

7.2 *Standard Reference Leather*^{6,7}—Leather sole material conforming to Federal Specification KK-L-165C (Type 1, Class 6).

7.3 *Leather/Shoe Pad Assembly*—Reference leather mounted on the machined shoe pad.

7.4 *Borco Board*²—drafting and drawing board working surface cover.

7.5 *Reference Surface*^{6,8}—Aluminum plate, 30.48 by 30.48 by 0.3175 cm (12 by 12 by 0.125 in.), which has been machined flat, to which 30.48 by 30.48 cm (12 by 12 in.) Borco board has been mounted, white side up.

7.6 *Chart*.^{6,9}

7.7 *Cleaner Solution*—Alcohol and water-based cleaner that does not leave a non-volatile residue, such as household window glass cleaner, or equivalent.

7.8 *Cleaning Cloth*—Clean, lint-free, absorbent cloth or white paper towel.

7.9 *Shoe Pad Stop*—Metal block, approximately 15 cm (6 in.) wide and long enough to fit between the James Machine test table retaining bar and the leading edge of the metal shoe pad when the strut is in the full upright position and the test table is in the start position. The shoe pad stop end shall be constructed so that it contacts only the machined shoe pad and not the leading edge of the leather. See Fig. 2. The shoe pad stop prevents slippage of the shoe pad during movement of the test table during calibration of the James Machine.

7.10 *Spring Clips or Drafting Tape*.

7.11 *Machinist's Square*.

8. Test Surface

8.1 For James Machine calibration the test surface assembly will consist of the working interface between the standard reference leather, mounted on the shoe pad, and the mounted Borco board reference surface, or between the mounted standard reference leather and the control polish applied and equilibrated on a Vinyl Composition Tile as described in Test Method D2047 and Practice D4103.

⁵ The sole sources of supply for the apparatus known to the committee at this time are as follows: assembled, motorized machines are available from Michelman, Inc., 9080 Shell Road, Cincinnati, OH 42536-1229. Assembled, non-motorized machines are available from Quadra, Inc., 1810 Renaissance Blvd., Racine, WI 53177-1743. Engineering/machinist drawings for motorized and manual transport James machines are available from Consumer Specialty Products Association, 1667 K Street, Suite 300, Washington, DC 20006.

⁶ If you are aware of alternative suppliers, please provide this information to ASTM Headquarters. Your comments will receive careful consideration at a meeting of the responsible technical committee, which you may attend.

⁷ The sole source of supply of precut leather, ready to mount on the test shoe pad, is available from Consumer Specialty Products Association, 1667 K Street, Suite 300, Washington, DC 20006.

⁸ The sole source of supply of a mounted reference surface known to the committee at this time is Technical Products Co., 264 Park Avenue, North Caldwell, NJ 07006.

⁹ The sole source of supply known to the committee at this time is Consumer Specialty Products Association, 1667 K Street, Suite 300, Washington, DC 20006.

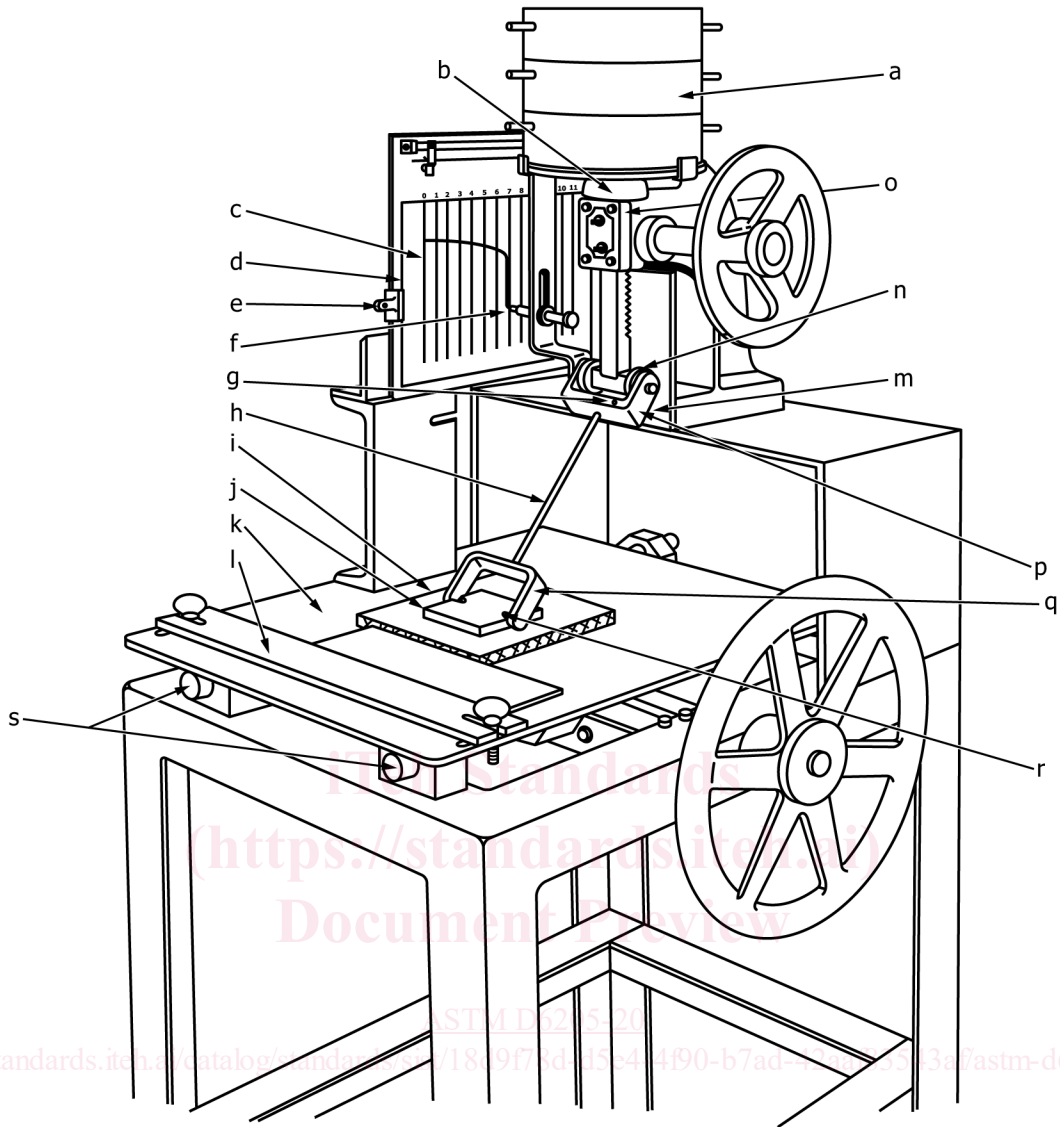

- a—Weights
- b—Cushion
- c—JSCOF Chart
- d—Chart Board
- e—Spring Clip
- f—Recording Pencil
- g—Set Screw
- h—Strut Arm
- i—Specimen
- j—Shoe Pad
- k—Test Table
- l—Retaining Bar
- m—Back Plate
- n—Upper Strut Pivot and Ball Bearing Rollers
- o—Gear Box (Rack and Pinion Gear, Strut Rack Gear)
- p—Upper Strut
- q—Lower Strut
- r—Lower Strut Pivot and Shoe Pad Pivot Cups
- s—Transport Guides

FIG. 1 James Machine