



Standard Specification for Detonation Flame Arresters¹

This standard is issued under the fixed designation F3386/F3386M; the number immediately following the designation indicates the year of original adoption or, in the case of revision, the year of last revision. A number in parentheses indicates the year of last reapproval. A superscript epsilon (ϵ) indicates an editorial change since the last revision or reapproval.

1. Scope-~~Scope~~*

1.1 This specification provides the minimum requirements for design, construction, performance, and testing of detonation flame arresters intended to protect against deflagrations, overdriven (unstable) detonations, stable detonations, and stabilized burning.

1.2 This specification is intended for detonation flame arresters installed in vapor control systems at Marine Facilities subject to the requirements in 33 CFR, Part 154, Subpart P — Marine Vapor Control Systems.

NOTE 1—In 1990, by permission from ASTM International, an earlier draft of this specification was incorporated and printed in 33 CFR, Part 154, Appendix A.

1.3 This specification is intended for detonation flame arresters protecting systems containing gases or vapors of liquids with flash points 140°F [60°C] (closed cup) or less. The tests in this specification are intended to qualify detonation flame arresters for all in-line applications, provided the operating pressure is equal to or less than the maximum operating pressure determined by testing and stated in the manufacturer's certification, and the diameter of the piping system in which the detonation flame arrester is to be installed is equal to or less than the piping diameter used in the testing.

1.4 This specification is limited to detonation flame arresters operating at temperatures no greater than 140°F [60°C], unless the detonation flame arresters are tested at the higher operating temperatures.

NOTE 2—Refer to UL 525 for additional requirements that may be applicable.

1.5 The values stated in either SI units or inch-pound units are to be regarded separately as standard. The values stated in each system ~~may~~ are not necessarily exact equivalents; therefore, to ensure conformance with the standard, each system shall be used independently of the other. ~~Combining other, and values from the two systems may result in non-conformance with the standard; shall not be combined.~~

1.6 *This standard does not purport to address all of the safety concerns, if any, associated with its use. It is the responsibility of the user of this standard to establish appropriate safety, health, and environmental practices and determine the applicability of regulatory limitations prior to use.*

1.7 *This international standard was developed in accordance with internationally recognized principles on standardization established in the Decision on Principles for the Development of International Standards, Guides and Recommendations issued by the World Trade Organization Technical Barriers to Trade (TBT) Committee.*

2. Referenced Documents

2.1 ASTM Standards:²

~~A395~~[A395/A395M](#) Specification for Ferritic Ductile Iron Pressure-Retaining Castings for Use at Elevated Temperatures

[F722](#) Specification for Welded Joints for Shipboard Piping Systems

[F1155](#) Practice for Selection and Application of Piping System Materials

2.2 ASME Standards:³

[ASME B16.5](#) Pipe Flanges and Flanged Fittings: NPS 1/2 through NPS 24 Metric/Inch Standard

¹ This specification is under the jurisdiction of ASTM Committee F25 on Ships and Marine Technology and is the direct responsibility of Subcommittee F25.11 on Machinery and Piping Systems.

Current edition approved Aug. 1, 2019/July 1, 2020. Published August 2019/July 2020. Originally approved in 2019. Last previous edition approved in 2019 as F3386/F3386M – 19. DOI: 10.1520/F3386_F3386M-19.10.1520/F3386_F3386M-20.

² For referenced ASTM standards, visit the ASTM website, www.astm.org, or contact ASTM Customer Service at service@astm.org. For *Annual Book of ASTM Standards* volume information, refer to the standard's Document Summary page on the ASTM website.

³ Available from American Society of Mechanical Engineers (ASME), ASME International Headquarters, Two Park Ave., New York, NY 10016-5990, http://www.asme.org.

*A Summary of Changes section appears at the end of this standard

ASME Boiler and Pressure Vessel Code Section VIII,
Division 1

ASME Boiler and Pressure Vessel Code Section IX

2.3 *Code of Federal Regulations (CFR)*:⁴

Title 33, Part 154 Facilities Transferring Oil or Hazardous Material in Bulk

2.4 *UL Standards*:⁵

UL 525 Standard for Flame Arresters

2.5 *Other Documents*:

International Electrotechnical Commission: 60079-20-1 Explosive Atmospheres – Part 20-1: Material Characteristics for Gas and Vapour Classification – Test Methods and Data⁶

3. Terminology

3.1 Definitions:

3.1.1 $\Delta P/P_o$, *n*—the dimensionless ratio, for any deflagration and detonation test in 9.3, of the maximum pressure increase (the maximum pressure minus the initial pressure), as measured in the piping system on the side of the detonation flame arrester where ignition begins by the device described in 9.3.3, to the initial absolute pressure in, P_o , the piping system.

3.1.1.1 Discussion—

The initial pressure should be greater than or equal to the maximum operating pressure specified in 11.1.6.

3.1.2 *deflagration*, *n*—a combustion wave that propagates subsonically (as measured at the pressure and temperature of the flame front) by the transfer of heat and active chemical species to the unburned gas ahead of the flame front.

3.1.3 *detonation*, *n*—a reaction in a combustion wave propagating at sonic or supersonic (as measured at the pressure and temperature of the flame front) velocity and characterized by a shock wave.

3.1.3.1 Discussion—

A detonation is stable when it has no significant variation of velocity and pressure or may be unstable during the transition of a combustion process from a deflagration into a stable detonation. The transition occurs in a limited spatial zone, where the velocity of the combustion wave is not constant and where the explosion pressure is significantly higher than in a stable detonation. When a deflagration transitions to a detonation, it must pass through the overdriven or unstable phase before becoming stable.

3.1.4 *detonation flame arrester*, *n*—a device which prevents the transmission of a detonation and a deflagration.

3.1.5 *flame passage*, *n*—the transmission of a flame through a device.

3.1.6 *flame speed*, *n*—the speed at which a flame propagates along a pipe or other system.

3.1.7 *gasoline vapors*, *n*—a non-leaded petroleum distillate consisting essentially of aliphatic hydrocarbon compounds with a boiling range approximating 149 to 167°F [65 to 75°C].

3.1.8 *marine facility*, *n*—a facility as defined in 33 CFR, Part 154.

3.1.9 *maximum experimental safe gap (MESG)*, *n*—the maximum clearance between two parallel metal surfaces that has been found, under specified test conditions, to prevent an explosion in a test chamber from being propagated to a secondary chamber containing the same gas or vapor at the same concentration.

4. Classification

4.1 The two types of detonation flame arresters covered in this specification are classified as follows:

4.1.1 *Type I*—Detonation flame arresters acceptable for applications where stationary flames may rest on the device.

4.1.2 *Type II*—Detonation flame arresters acceptable for applications where stationary flames are unlikely to rest on the device, and further methods are provided to prevent flame passage when a stationary flame occurs. One example of “further methods” is a temperature monitor which activates a fire safe automatic shutoff valve.

5. Ordering Information

5.1 Orders for detonation flame arresters under this specification shall include the following information as applicable:

5.1.1 Type (I or II),

5.1.2 Nominal pipe size,

⁴ Available from U.S. Government Printing Office, Superintendent of Documents, 732 N. Capitol St., NW, Washington, DC 20401-0001, <http://www.access.gpo.gov>.

⁵ Available from Underwriters Laboratories (UL), UL Headquarters, 333 Pfingsten Road, Northbrook, IL, 60062, <http://www.ul.com>.

⁶ Available from International Electrotechnical Commission (IEC), 3, rue de Varembe, 1st floor, P.O. Box 131, CH-1211, Geneva 20, Switzerland, <https://www.iec.ch>.

- 5.1.3 Each gas or vapor in the system and the corresponding MESH,
- 5.1.4 Inspection and tests other than specified by this standard,
- 5.1.5 Anticipated ambient air temperature range,
- 5.1.6 Purchaser's inspection requirements (see 10.1),
- 5.1.7 Description of installation,
- 5.1.8 Materials of construction (see Section 6),
- 5.1.9 Maximum flow rate and the maximum design pressure drop for that maximum flow rate, and
- 5.1.10 Maximum operating pressure.

6. Materials

6.1 The detonation flame arrester housing, and other parts or bolting used for pressure retention, shall be constructed of materials listed in Practice F1155, or Section VIII, Division 1, of the ASME Boiler and Pressure Vessel Code. Cast and malleable iron shall not be used; however, ductile cast iron in accordance with Specification A395A395/A395M may be used.

6.2 Detonation flame arresters, elements, gaskets, and seals must be made of materials resistant to attack by seawater and the liquids and vapors contained in the system being protected (see 5.1.3).

6.3 Nonmetallic materials, other than gaskets and seals, shall not be used in the construction of pressure-retaining components of the detonation flame arrester.

6.4 Nonmetallic gaskets and seals shall be non-combustible and suitable for the service intended.

6.5 Bolting materials, other than those in 6.1, shall be at least equal to those listed in Table 1 of ASME B16.5.

6.6 The possibility of galvanic corrosion shall be considered in the selection of materials.

6.7 All other parts shall be constructed of materials suitable for the service intended.

7. Other Requirements

7.1 Detonation flame arrester housings shall be gas-tight to prevent the escape of vapors.

7.2 Detonation flame arrester elements shall fit in the housing in a manner that will ensure tightness of metal-to-metal contacts in such a way that flame cannot pass between the element and the housing.

7.2.1 The net free area through detonation flame arrester elements shall be at least 1.5 times the cross-sectional area of the arrester inlet.

7.3 Housings, elements, and seal gasket materials shall be capable of withstanding the maximum and minimum pressures and temperatures to which the device may be exposed under both normal and the specified fire test conditions in Section 9 and shall be capable of withstanding the corrosion test in 8.2.2, the hydrostatic pressure test in 8.2.3, the pneumatic test in 8.2.10, and the production tests in 10.3.

7.4 Threaded or flanged pipe connections shall comply with the applicable ASME B16 standards in accordance with Practice F1155. Welded joints shall comply with Specification F722.

7.5 All flat joints of the housing shall be machined true and shall provide for a joint having adequate metal-to-metal contact.

7.6 Where welded construction is used for pressure-retaining components, welded joint design details, welding and non-destructive testing shall be in accordance with Section VIII, Division 1, of the ASME Code and Specification F722. Welders and weld procedures shall be qualified in accordance with Section IX of the ASME Code.

7.7 The design of detonation flame arresters shall allow for ease of inspection and removal of internal elements if necessary, for such operation as cleaning, repair or replacement.

7.8 Detonation flame arresters shall allow for efficient drainage of condensate without impairing their efficiency to prevent the passage of flame. The housing may be fitted with one or more drain plugs for this purpose. The design of a drain plug shall be such that by cursory visual inspection it is obvious whether the drain was left open.

7.9 All fastenings shall be protected against loosening.

7.10 Detonation flame arresters shall be designed and constructed to minimize the effect of fouling under normal operating conditions.

7.11 Detonation flame arresters shall be capable of operating over the full range of ambient air temperatures anticipated.

7.12 Detonation flame arresters shall be of first class workmanship and free from imperfections which may affect their intended purpose.

7.13 Detonation flame arresters shall be tested in accordance with the tests described in Section 8.

8. Prototype Tests

8.1 Tests shall be conducted by an independent laboratory capable of performing the tests. The manufacturer, in choosing a laboratory, accepts that it is a qualified independent laboratory by determining that it has (or has access to) the apparatus, facilities, personnel, and calibrated instruments that are necessary to test detonation flame arresters in accordance with this specification.

8.1.1 A test report shall be prepared by the laboratory which shall include:

8.1.1.1 Detailed drawings of the detonation flame arrester and its components (including a parts list identifying the materials of construction).

8.1.1.2 Types of tests conducted and results obtained. This shall include the maximum temperature reached and the length of testing time in 9.2 in the case of Type II detonation flame arresters.

8.1.1.3 Description of approved attachments (see 8.2.7).

8.1.1.4 Types of gases or vapors for which the detonation flame arrester is approved.

8.1.1.5 Drawings of the test rig.

8.1.1.6 Initial test pressure and test temperature.

8.1.1.7 Record of all markings found on the tested detonation flame arrester.

8.1.1.8 A report number.

8.2 One of each model Type I and Type II detonation flame arrester shall be tested. Where approval of more than one size of a detonation flame arrester design series is desired, only the largest, smallest, and one intermediate size of the design series need be tested provided it is demonstrated by calculation or other testing, or both, that the other intermediate size devices have equal or greater strength to withstand the force of a detonation and have equivalent detonation arresting characteristics. A change of design, material, or construction which may affect the corrosion resistance or ability to resist endurance burning, deflagrations or detonations shall be considered a change of model for the purpose of this paragraph.

8.2.1 The detonation flame arrester shall have the same dimensions, configuration, and most unfavorable clearances expected in production units. If a test device is modified during the test program, the testing shall be started over again.

8.2.2 A corrosion test shall be conducted. In this test, a complete detonation flame arrester, including a section of pipe similar to that to which it will be fitted, shall be exposed to a 20 % sodium chloride solution spray at a temperature of 77°F [25°C] for a period of 240 h and allowed to dry for 48 h. Following this exposure, all movable parts shall operate properly and there shall be no corrosion deposits which cannot be washed off.

8.2.3 The detonation flame arrester shall be subjected to a hydrostatic pressure test of at least 350 psig [2.4 MPa] for 10 min without rupturing, leaking, or showing permanent distortion.

8.2.4 Flow characteristics as declared by the manufacturer shall be demonstrated by appropriate tests.

8.2.5 Detonation flame arresters shall be subjected to tests for deflagration, detonation, and endurance burn, in accordance with the test procedures in Section 9. The same detonation flame arrester shall be used for all tests. Detonation flame arresters designed to operate at pressures other than atmospheric shall be tested at a pressure equal to or greater than the upper limit of the device's maximum operating pressure (see 11.1.6). Type I detonation flame arresters shall show no flame passage when subjected to all three tests. Type II detonation flame arresters shall show no evidence of flame passage during the detonation/deflagration tests in 9.3. Type II detonation flame arresters shall be tested for endurance burn in accordance with 9.2. From the endurance burn test of a Type II detonation flame arrester, the maximum temperature reached and the test duration shall be recorded and provided as part of the laboratory test report.

8.2.6 When tested in accordance with Section 9, detonation flame arresters shall prevent the transmission of flame and detonation flame arrester housings shall be able to withstand, without damage or permanent deformation, the internal pressure and temperatures resulting from both stable and overdriven (unstable) detonations and endurance burning.

8.2.7 Where a detonation flame arrester is provided with cowls, weather hoods and deflectors, etc., it shall be tested in each configuration in which it is provided.

8.2.8 Detonation flame arresters which are provided with a heating arrangement shall pass the required tests with the heating arrangement installed and operating at the maximum heated operating temperature.

8.2.9 Detonation flame arresters designed for operating at temperatures greater than 140°F [60°C], shall be tested at temperatures greater than or equal to the maximum operating temperature.

8.2.10 After completing all other required tests, each detonation arrester shall be pneumatically tested at 10 psig [70 kPa] for 10 min to ensure there is no leakage.

9. Test Procedures for Detonation Flame Arresters

9.1 Media/Air Mixtures:

9.1.1 For detonation flame arresters intended for use with vapors from flammable or combustible liquids with a MESG greater than or equal to 0.0354 in. [0.9 mm], technical grade hexane or gasoline vapors shall be used for the endurance burn test in 9.2, and technical grade propane shall be used for the deflagration/detonation tests in 9.3. For detonation flame arresters intended for use with vapors with a MESG less than 0.0354 in. [0.9 mm], the specific vapor (or alternatively, a media with a MESG less than or equal to the MESG of the vapor) shall be used as the test medium in all Section 9 tests.

9.1.2 Hexane, propane, gasoline, and other test media shall be mixed with air to form the most easily ignitable mixture.⁷

9.2 Endurance Burn Test Procedure:

9.2.1 An endurance burning test using the appropriate test media/air mixtures required in 9.1 and at a pressure equal to or greater than the upper limit of the device's maximum operating pressure (see 11.1.6) shall be carried out as follows:

9.2.1.1 The test shall be performed using the test arrangement shown in Fig. 1. The test arrangement shall consist of an apparatus producing an explosive mixture, a small tank with a bursting diaphragm, a prototype of the detonation flame arrester, an ignition source in close proximity to the test device, required sensors, piping and valves. The pipe diameter used shall be that which is intended for use with the flame arrester and as specified by the manufacturer. The pipe used shall have a pressure rating suitable for the test. The length of the pipe, L_U , on the unprotected side shall be five pipe diameters long. The test arrangement shall have a flame detector, flame sensor, plastic bursting diaphragm or a plastic bag, or a combination thereof, to detect the propagation of flame through the unit. The detonation flame arrester shall be installed in the position for which it is designed and which will cause the most severe heating of the device under the prescribed endurance burn conditions. In this position the mixture shall be ignited.

NOTE 3—The test apparatus shown in Fig. 1 shall be modified to allow the endurance burn test to be conducted at a test pressure equal to or greater than the upper limit of the detonation flame arrester maximum operating pressure (see 11.1.6).

9.2.1.2 Endurance burn test shall start by using the appropriate most easily ignitable test media/air mixture (see 9.1) with the aid of a continuously operated pilot flame or a continuously operated igniter at the outlet. The flammable mixture may be reignited as necessary in the course of the endurance burn. The temperature of the test gas shall be within the range of 59 to 104°F [15 to 40°C].

9.2.1.3 Temperature measurement shall be performed on the surface of the arrester element using two temperature sensors located at the lowest and highest points half way between the center and its edge on both the protected and unprotected side (see Fig. 1).

9.2.1.4 By varying the proportions of the flammable mixture and the flow rate, the detonation flame arrester shall be heated by a stable flame on the surface of the arrester element until the highest obtainable temperature is reached on the ignited side or until the temperature on the side which was not ignited (protected side) rises 180°F [100°C].

NOTE 4—If the test flow velocity is in excess of the burn-back velocity, a flame will establish itself at the end of the unprotected pipe. In this case, reduce the gas flow rate so that the flame enters the pipe and progresses back to the flame arrester element. Once the flame has travelled back to the flame arrester element, increase the velocity back to the test flow rate.

9.2.1.5 The flammable mixture proportions shall be varied again until the conditions which result in the highest temperature on the protected side is achieved. This temperature shall be maintained for a period of ten minutes, after which the flow shall be stopped and the condition of the detonation flame arrester shall be observed. The highest attainable temperature is considered to have been reached when any subsequent rise of temperature does not exceed 0.9°F [0.5°C] per minute over a 10-min period.

9.2.1.6 If difficulty arises in establishing the highest attainable temperature on the protected side, the following criteria shall apply. When the increase in temperature on the protected side occurs so slowly that its temperature does not rise 180°F [100°C], the test mixture and flow rate which produced the highest temperature on the ignited side of the flame arrester shall be maintained for two hours. For the situation in which the temperature on the protected side of the flame arrester continues to rise at a rate in excess of 0.9°F [0.5°C] per minute for a 10-min period, endurance burning shall be continued, using the test mixture and flow rate which caused the highest temperature rate rise, for a period of two-hours. In either of these cases, at the end of the two-hour period, the flow shall be stopped and the detonation flame arrester shall be visually examined for damage or permanent deformation, or both. The results of the examination shall be recorded in the test report. The two-hour interval shall be measured commencing with the setting of the test mixture and flow rate which produced the most severe temperature conditions.

9.2.1.7 For Type I detonation flame arresters, flame passage shall not occur during this test.

9.2.1.8 For Type II detonation flame arresters, the maximum temperature obtained, and the time elapsed from the time when the most severe conditions are set to when flame passage occurs, shall be recorded. However, for Type II detonation flame arresters the test may be terminated 15 min after setting the most severe conditions on the protected side.

9.3 Deflagration/Detonation Test Procedure:

9.3.1 A detonation flame arrester shall be installed at one end of a pipe of the same diameter as the inlet of the detonation flame arrester (see Fig. 2, Fig. 3, and Fig. 4). The length and configuration of the test pipe, L_U , shall develop a stable detonation⁸ at the device and shall be capable, by change in its length or configuration, of developing deflagrations and overdriven (unstable) detonations as measured on the side of the pipe where ignition occurs (unprotected side). In each of the arrangements (see Fig. 2, Fig. 3, and Fig. 4) the free end of the outlet side pipe (protected end) shall be closed with a pressure resistant flange. In addition, arrangements shall be made to ensure the required gas concentration is maintained throughout the test piping arrangement.

⁷ See IEC 60079-20-1.

⁸ Some data are available for the estimation of flame speeds in horizontal pipes without detonation flame arresters. Some data indicate that the presence of small obstacles, fittings or bends in the test pipe can accelerate the flame speeds appreciably.

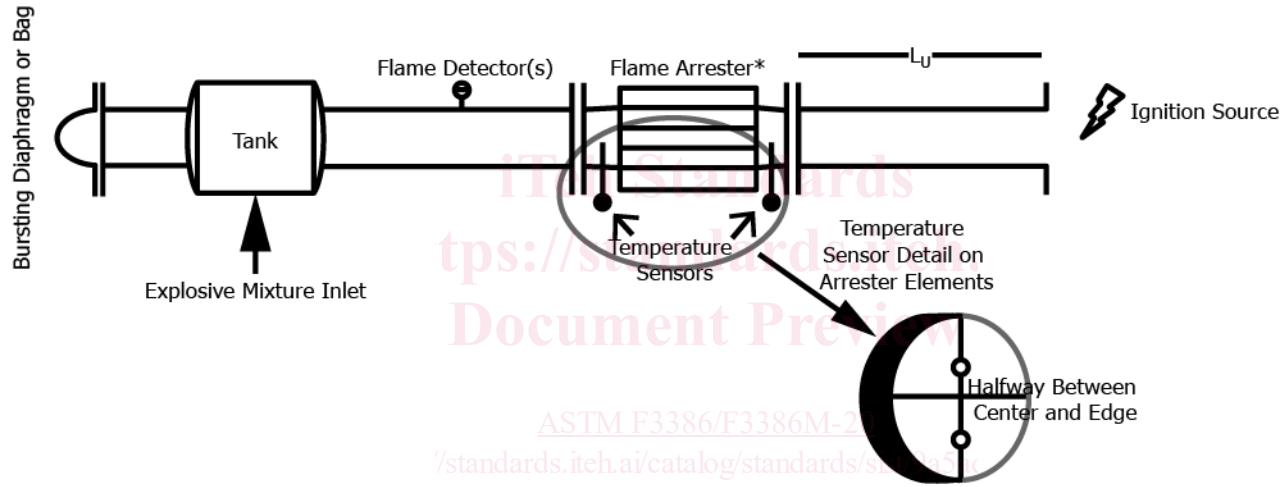

* Note, flame arrester shall be installed in the position for which it is designed and which causes the most severe heating of the device under the prescribed burning conditions which may be vertically.

FIG. 1 General Test Arrangement for Endurance Burn (Not to Scale)

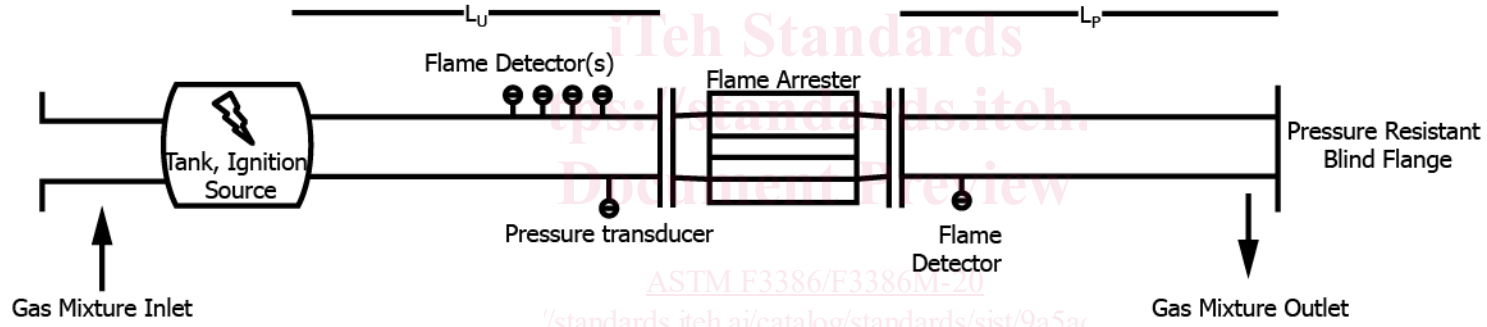

FIG. 2 General Test Arrangement for Detonation
(Not to Scale)