



Designation: E3037 – 20

# Standard Test Method for Measuring Relative Movement Capabilities of Through-Penetration Firestop Systems<sup>1</sup>

This standard is issued under the fixed designation E3037; the number immediately following the designation indicates the year of original adoption or, in the case of revision, the year of last revision. A number in parentheses indicates the year of last reappraisal. A superscript epsilon ( $\epsilon$ ) indicates an editorial change since the last revision or reappraisal.

## 1. Scope

1.1 This test method covers testing procedures for through-penetration firestop systems. This test method is intended for the following uses:

NOTE 1—Refer to Test Method E814 for definition of “through-penetration firestop system.”

1.1.1 To determine relative movement capability in two separate and distinct planes of movement for different types of through-penetration firestop systems,

1.1.2 To standardize a comparison of movement capability by establishing standardized test conditions, in order to allow the type of through-penetration firestop system’s movement capabilities to be examined,

1.1.3 To provide the user with information on amplitudes of relative movement between the penetrating items and the substrate (concrete-based or gypsum-based).

NOTE 2—Amplitude is the measure of change over a single cycle.

1.2 This test method is intended to be used only as part of a specification or acceptance criteria due to the limited movements tested, and limited number of variables examined.

1.3 This test method uses standardized configurations for the test specimen. Test results will not be representative of all possible through-penetration firestop systems.

1.4 The values stated in inch-pound units are to be regarded as standard. The values given in parentheses are mathematical conversions to SI units that are provided for information only and are not considered standard.

1.5 *The text of this standard references notes, comments, and footnotes which provide explanatory material. These notes, comments, and footnotes (excluding those in tables and figures) shall not be considered requirements of this standard.*

1.6 *This standard does not purport to address all of the safety concerns, if any, associated with its use. It is the*

*responsibility of the user of this standard to establish appropriate safety, health, and environmental practices and determine the applicability of regulatory limitations prior to use. Some specific hazards statements are given in Section 7 on Safety Hazards.*

*1.7 This international standard was developed in accordance with internationally recognized principles on standardization established in the Decision on Principles for the Development of International Standards, Guides and Recommendations issued by the World Trade Organization Technical Barriers to Trade (TBT) Committee.*

## 2. Referenced Documents

### 2.1 ASTM Standards:<sup>2</sup>

E119 Test Methods for Fire Tests of Building Construction and Materials

E176 Terminology of Fire Standards

E631 Terminology of Building Constructions

E814 Test Method for Fire Tests of Penetration Firestop Systems

E1399/E1399M Test Method for Cyclic Movement and Measuring the Minimum and Maximum Joint Widths of Architectural Joint Systems

### 2.2 ISO Standards:<sup>3</sup>

ISO 834 Fire-resistance tests -- Elements of building construction

ISO 10295-1 Fire tests for building elements and components -- Fire testing of service installations -- Part 1: Penetration seals

### 2.3 UL Standards:<sup>4</sup>

UL 263 Standard for Fire Tests of Building Construction and Materials

ANSI/UL 1479 Standard for Fire Tests of Penetration Firestops

<sup>2</sup> For referenced ASTM standards, visit the ASTM website, [www.astm.org](http://www.astm.org), or contact ASTM Customer Service at [service@astm.org](mailto:service@astm.org). For *Annual Book of ASTM Standards* volume information, refer to the standard’s Document Summary page on the ASTM website.

<sup>3</sup> Available from International Organization for Standardization (ISO), ISO Central Secretariat, BIBC II, Chemin de Blandonnet 8, CP 401, 1214 Vernier, Geneva, Switzerland, <http://www.iso.org>.

<sup>4</sup> Available from Underwriters Laboratories (UL), 2600 N.W. Lake Rd., Camas, WA 98607-8542, <http://www.ul.com>.

<sup>1</sup> This test method is under the jurisdiction of ASTM Committee E06 on Performance of Buildings and is the direct responsibility of Subcommittee E06.21 on Serviceability.

Current edition approved July 1, 2020. Published July 2020. Originally approved in 2016. Last previous edition approved in 2019 as E3037–19. DOI: 10.1520/E3037-20.

### 2.4 ULC Standards:<sup>5</sup>

**CAN/ULC-S101** Standard Methods of Fire Endurance Tests of Building Construction and Materials

**CAN/ULC-S115** Standard Method of Fire Tests of Firestop Systems

### 2.5 Other Standards:

**EN 1366** Fire resistance tests for service installations<sup>6</sup>

**FEMA 461** Interim Testing Protocols for Determining the Seismic Performance Characteristics of Structural and Nonstructural Components<sup>7</sup>

**IMO FTP Code** International Code for the Application of Fire Test Procedures<sup>8</sup>

## 3. Terminology

3.1 For definitions of terms used in this test method and associated with building issues, refer to the definitions contained in Terminology **E631**. For definitions of terms used in this test method and associated with fire issues, refer to the definitions contained in Terminology **E176**.

3.2 When there is a conflict between Terminology **E631** and Terminology **E176** definitions, Terminology **E176** definitions shall apply.

### 3.3 Definitions of Terms Specific to This Standard:

3.3.1 *allowable movement, n*—the cyclic displacement length measured and recorded from a given test series prior to the one for which failure of the through-penetration firestop system was observed.

3.3.2 *annular space, n*—the distance, measured in a straight line, between the outer most portion of the penetrating item and the inside periphery of the opening in the test assembly.

3.3.3 *cyclic movement, n*—the periodic change between the extremes of movement in one plane in an automatically mechanically controlled system.

3.3.4 *penetrating item, n*—the continuous item that traverses from one side of a wall or floor or roof to the opposite side through the opening in the assembly.

3.3.4.1 *Discussion*—Examples of penetrating items include cables, conduits, ducts, pipes.

3.3.5 *substrate, n*—the material of the wall assembly or roof assembly that the through-penetration passes through.

3.3.6 *test specimen, n*—the penetrating item or items, the test assembly through which the penetrating items are arranged to pass, and the materials or devices, or both, that seal the opening in the through-penetration firestop system being tested.

3.3.7 *type of through-penetration firestop system, n*—the unique combination of penetrating item type (for example, metal pipe, plastic pipe, cabling), substrate type (concrete-

based or gypsum-based), and firestop material or device, including their method of installation.

3.3.8 *y-direction, n*—the direction of movement parallel to the surface of the test assembly.

3.3.9 *z-direction, n*—the direction of movement perpendicular to the surface of the test assembly.

## 4. Summary of Test Method

4.1 A rectangular test assembly is made from concrete or gypsum board according to the targeted application. The penetrating item and firestop materials are chosen to represent the type of through-penetration firestop system for which movement data is desired.

NOTE 3—A simplified example of such a test assembly is shown schematically in **Fig. 1**.

4.2 Two independent tests are conducted for each combination of through-penetration firestop system type and test assembly. One of the tests cycles the penetrating item in the direction perpendicular to the plane of the test assembly. A second independent test is conducted to cycle the through-penetration firestop system in the direction parallel to the plane of the test assembly. The cycling tests continue to the magnitude requested by the test sponsor, as adjusted by ongoing observations during the test.

4.3 The cyclic movement tests are followed by a fire resistance test of each test assembly, as described in **9.11**, to establish the fire resistance rating of each such assembly.

## 5. Significance and Use

5.1 This test method is intended to standardize the cyclic movement of a through-penetration firestop system prior to a fire resistance test. If the amplitude of movement in a design application can be predicted, then the numerical values of allowable movement can be used as one data point in helping to establish suitability of the through-penetration firestop system for the given application.

NOTE 4—The fire resistance rating of a through-penetration firestop system is established in accordance with a relevant fire test, as acceptable to the Authority Having Jurisdiction. Examples of such tests include Test Method **E814**, **CAN/ULC-S115**, **UL 1479**, and **ISO 10295-1**.

5.2 This test method will assist users, producers, building officials, code authorities, and others in understanding relative movement capabilities of representative test specimens of through-penetration firestop systems under standardized test conditions.

5.3 This test method is not intended to predict the absolute movement capabilities of all likely permutations of through-penetration firestop systems under all likely types of real-life movement.

5.4 This test method does not provide information on:

5.4.1 Durability of the through-penetration firestop system under actual service conditions, including the effects of cycled temperature on the through-penetration firestop system;

5.4.2 Rotational shear capabilities of the test specimen;

<sup>5</sup> Available from ULC Canada, 7 Underwriters Road, Toronto, Ontario, Canada M1R 3A9, <http://canada.ul.com/ulcstandards>.

<sup>6</sup> Available from European Committee for Standardization (CEN), Avenue Marnix 17, B-1000, Brussels, Belgium, <http://www.cen.eu>.

<sup>7</sup> Available from Federal Emergency Management Agency (FEMA), 500 C St., SW, Washington, DC 20472, <http://www.fema.gov>.

<sup>8</sup> Available from International Maritime Organization (IMO), 4 Albert Embankment, London SE1 7SR, United Kingdom, <http://www.imo.org>.

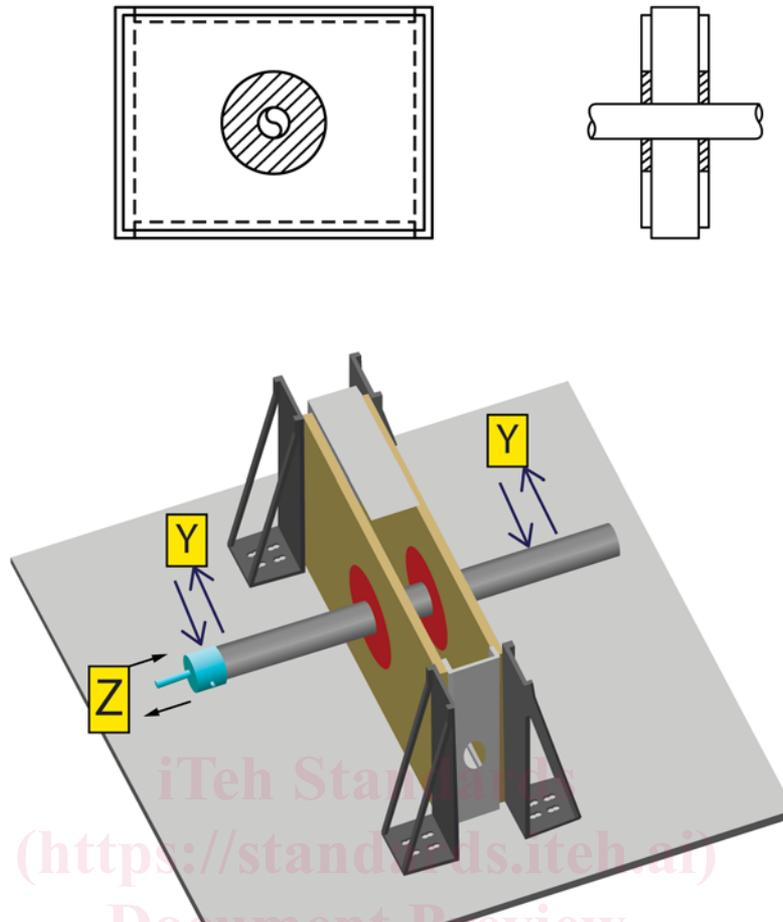

FIG. 1 Simplified Example of Test Assembly Used for Movement Testing, Y-direction and Z-direction of Cycle Movement Shown

5.4.3 Any other attributes of the test specimen, such as wear resistance, chemical resistance, air infiltration, water-tightness, and so forth; and

5.4.4 Compatibility of through-penetration firestop system components and the penetrating items.

5.5 This test method is only to be used as one element in the selection of a through-penetration firestop system for a particular application.

5.6 This is not a fire test standard. To determine the effect of cyclic movement on the fire resistance rating of a through-penetration firestop system, conduct a fire test in accordance with a fire resistance test method acceptable to the Authority Having Jurisdiction subsequent to this movement test.

## 6. Apparatus

6.1 *Testing Machine*, capable of a range of movement that includes the maximum z-direction and y-direction movement planned for the test. It shall be capable of continual repetitious movement between two specified dimensions, equipped with an automatic counter to record the relative movement between the penetrating item and the test assembly during the test.

6.2 *Measuring Device*, capable of an accuracy of 0.010 in.  $\pm$  0.005 in. (0.25 mm  $\pm$  0.013 mm).

NOTE 5—One example of a commonly used measuring device is the

Linear Variable Differential Transformer (LVDT).

NOTE 6—If a load cell is connected to the displacement device, it might be damaged if the resistance to movement exceeds the rated capacity of the load cell.

6.3 *Mounting Plates*, or other apparatus suitable to install the test specimen and undergo the test procedures.

## 7. Safety Hazards

7.1 **Warning**—Take proper precautions to protect the observers in the event of any failure. If extreme pressures develop during this test, considerable energy and hazard are involved. In cases of failure, the hazard to personnel is less if a protective shield is used and protective eye wear worn. Do not permit personnel between the shield and equipment during the test procedure.

## 8. Test Specimens

8.1 *Test Assembly*:

8.1.1 A concrete substrate shall be 4.5 in.  $\pm$  0.50 in. (114 mm  $\pm$  13 mm) thick. The concrete used shall have a nominal density of 150 pcf (2403 kg/m<sup>3</sup>) and a minimum compressive strength of 3000 psi (20.68 MPa).

NOTE 7—This dimension has been selected to provide a generic, representative test assembly that can provide meaningful data for a wide variety of conditions.

NOTE 8—The concrete types or dimensions as permitted by 8.1.5 will result in different test assemblies when needed.

8.1.2 Prior to the test, condition concrete test specimens in an ambient atmosphere of 50 % to 75 % relative humidity at  $73\text{ °F} \pm 5\text{ °F}$  ( $23\text{ °C} \pm 3\text{ °C}$ ) until an equilibrium moisture condition is achieved within the test specimen (Note 9).

8.1.3 With some concrete construction it is difficult or impossible to achieve such uniformity. Where this is the case, test specimens shall be permitted to be tested when the dampest portion of the test specimen has achieved a moisture content corresponding to conditioning to equilibrium with air in the range of 50 % to 75 % relative humidity at  $73\text{ °F} \pm 5\text{ °F}$  ( $23\text{ °C} \pm 3\text{ °C}$ ).

NOTE 9—A recommended method for determining the relative humidity within a hardened concrete test specimen with electric sensing elements is described in Appendix I of the paper by Menzel.<sup>9</sup> A similar procedure with electric sensing elements is permitted to be used to determine the relative humidity within test specimens made with other materials.

8.1.4 A gypsum wall assembly shall consist of 1 h fire resistance rated construction using  $\frac{5}{8}$  in. or 16 mm nominal thickness boards mounted on  $\frac{3}{8}$  in. (92 mm) nominal 24 gauge studs. Stud spacing shall be 16 in.  $\pm$  0.5 in. (381 mm  $\pm$  13 mm). The assembly shall consist only of gypsum boards, framing members, tracks, and screws. It shall be fastened as specified in the listing of the 1 h assembly used. The gypsum board shall not be of the abuse-resistant or impact-resistant types, unless that board type is reported, as mandated by 8.1.5. The testing machine's attachment to the test assembly shall not rest or otherwise support the free span of gypsum board between studs. In the direction parallel to the studs, the gypsum board span shall not have any rigid supports at either end, or if a support is necessary at one or both ends, the gypsum board shall have a minimum unsupported free span of 14 in. (356 mm) as measured parallel to the studs. The opening in the gypsum wall for the through-penetration shall be centered within the assembly. The opening is permitted to be framed or not framed, depending on the condition that is being investigated.

NOTE 10—This gypsum wall assembly has been chosen to provide a generic, representative test assembly that can provide meaningful data for a wide variety of conditions.

NOTE 11—The minimum free span of gypsum board is being specified due to the possibility that gypsum board flexure during movement testing in the z-direction will influence the results.

8.1.5 Other substrate types, thicknesses, and variations shall be permitted to be tested, as needed, to produce data that is representative of field conditions that are not well represented by the concrete or gypsum test assemblies specified in 8.1.1 through 8.1.4. When materials, dimensions, or characteristics different than those specified in 8.1.1 through 8.1.4 are used for the test assembly, indicate in the test report that a non-standard test assembly was used, as well as why that non-standard test assembly was selected.

8.1.6 The test assembly substrate shall be a new, never-before-used substrate.

8.1.7 When the through-penetration firestop system is composed of sealants, and the penetrating item or group of penetrating items is closer to circular than to rectangular in cross-section, the opening in the test assembly to accommodate the penetrating item shall be round, with the penetrating item placed at its geometric center.

8.1.8 When the through-penetration firestop system is composed of sealants, and the penetrating item or group of penetrating items is closer to rectangular than to circular in cross-section, the opening in the test assembly to accommodate the penetrating item shall be rectangular, with equal annular space on all four sides as specified in 8.1.10.

8.1.9 When the through-penetration firestop system is composed of pre-formed firestop devices, the hole may be of any shape and size as representative of the end use application.

8.1.10 When the through-penetration firestop system is composed of sealants, the opening in the test assembly that will accommodate the penetrating item shall be of such size that the annular space is 2.5 in.  $\pm$  0.125 in. (64 mm  $\pm$  3.2 mm) for a circular opening, and if the opening is square, the distance to the mid-point of all four sides shall be 2.5 in.  $\pm$  0.125 in. (64 mm  $\pm$  3.2 mm).

8.1.10.1 When a 2.5 in. (64 mm) annular space is known to be unable to pass a fire resistance test, even without movement cycling, the annular space shall be permitted to be the largest available for the specific combination of sealant, substrate, and penetrating item, as determined by previous fire testing.

8.1.11 When movement testing is to be performed with the objective of establishing that a non-zero amount of movement is allowable in the y-direction or in the z-direction for firestop systems composed of sealants and with the penetrating item having a point of contact with the substrate, a separate, additional movement test shall be conducted for that condition. The additional test shall have the penetrating item firestopped in contact with the substrate prior to movement testing. The annular space on the side of the penetrating item opposite to the point of contact shall be a minimum of 2.5 in., unless otherwise allowable by 8.1.10.1.

NOTE 12—Without testing specifically for the point of contact condition, the movement capability as calculated by the Extension of Data in Appendix X3 for a point of contact condition would always be calculated to be zero.

8.1.11.1 The y-direction movement cycle specified in 9.6 shall be permitted to be modified so that the penetrant has only one direction of movement, away from the zero position, as opposed to the back-and-forth movement otherwise required in 9.6. The penetrating item shall be moved away from the zero position in a direction away from the point of contact, for the distance indicated in Table 1, then returning to the zero position to complete one movement cycle.

NOTE 13—Movement in the direction towards the point of contact is not physically possible, since the point of contact precludes further movement of the penetrant towards the substrate.

## 8.2 Penetrating Items:

8.2.1 The penetrating item shall be centered in the opening.

NOTE 14—Although the standardized test condition is specified with the penetrating item centered in the opening, real life installations typically involve penetrating items not centered in the opening. The test method can

<sup>9</sup> Menzel, C. A., "A Method for Determining the Moisture Condition of Hardened Concrete in Terms of Relative Humidity," Proceedings, ASTM, Vol 55, 1955, p. 1085.

**TABLE 1 Displacement Sequence for Y-direction  
Movement Amplitude**

Repeats	Displacement (in.)
10	0.125
3	0.15
3	0.18
3	0.22
3	0.26
3	0.31
3	0.37
3	0.45
3	0.54
3	0.64
3	0.77
3	0.93
3	1.11
3	1.34
3	1.60
3	1.93
3	2.32
3	<sup>A</sup>

<sup>A</sup> Table may be extended indefinitely using Repeats = 3 and Displacement =  $D_s \times 1.2$  ( $D_s$  is displacement at last sequence). For annular spaces less than  $D_s$ , it is permissible for  $D_s$  = annular space.

nevertheless provide useful data for those off-center installations, such as by using the Extension of Data methods described in **Appendix X3** on the annular space values of an actual field installation.

8.2.2 When a plastic pipe is used for the penetrating item, a minimum schedule 40 pipe shall be used, or equivalent thickness where a different pipe thickness nomenclature is used.

8.2.3 Pipes or bundles of pipes, such as a line set, shall be installed in the center of the opening.

8.2.4 When testing a through-penetration firestop system that is tested and listed for cable bundles, the cable bundle shall be sufficiently stiffened by inserting rigid materials such as an angle iron inside the bundle. The inserted rigid material shall be located at the approximate center of the bundle.

8.2.5 In cases when a cable tray is tested, lay a single layer of cables with a diameter of  $\frac{1}{2}$  in.  $\pm$   $\frac{1}{8}$  in. (13 mm  $\pm$  3 mm) to cover the bottom of the cable tray. Affix the cables to the tray eliminating the relative movement between the cables and the cable tray when cyclic movement is conducted in the y-direction and z-direction.

8.2.6 When testing ducts, the following shall apply:

(a) The shape of the opening in the test assembly shall be determined by the test sponsor, so as to replicate the real-life relationship between opening shape and duct shape.

(b) a minimum 4 in.  $\pm$   $\frac{1}{2}$  in. (100 mm  $\pm$  13 mm) diameter round duct, or minimum 4 in. by 4 in.  $\pm$   $\frac{1}{2}$  in. (100 mm by 100 mm  $\pm$  13 mm) square duct shall be used as a representative duct.

8.2.7 When an insulated pipe is to be tested, the insulation and pipe shall be bonded together so as to ensure that they move together, without any differential movement in the z-direction.

### 8.3 Penetrating Item Support:

8.3.1 The penetrating item shall be secured on each side of the test assembly, but independent of the test assembly so as to allow the cyclic movement. Unless specifically requested

otherwise by the test sponsor, the penetrating item shall be oriented approximately perpendicular to the test assembly at an angle of  $90^\circ \pm 5^\circ$ .

8.3.2 The penetrating item shall be permitted to be supported by attachment to the test assembly during the period when the test specimen is being built, cured if necessary and transported to the testing machine.

NOTE 15—For penetrating items that are relatively heavy, consideration should be given to the means of transferring the test sample from the location where the through-penetration firestop system is installed and cured, if necessary, to the location of the testing machine, without damaging the through-penetration firestop system due to the dead weight of the penetrating item. Similar consideration should be given to the means of transferring the test sample from the location where the movement testing is performed to the location of the fire test furnace.

### 8.4 Through-penetration Firestop System Installation:

8.4.1 Components of a through-penetration firestop system shall be installed in a manner that is representative of how those components are specified for installation in the fire resistance rated design listings for which the movement test is intended to be referenced, and in accordance with the manufacturer's published installation instructions.

NOTE 16—Examples of listed through-penetration firestop system details that must be conformed to include mechanical fastening and attachment methods for solid components, sealant depth, tooling for sealants, and compression for backing materials.

NOTE 17—Although the generalized and standardized nature of this test procedure is intended to produce results that can be applied to more than a single listed through-penetration firestop system, compliance with installation instructions that are part of a through-penetration firestop system listing can impact the results of this test, either in helping or hindering the test specimen's ability to withstand movement prior to damage. The test results from this test would normally be considered to apply only to listed through-penetration firestop systems with installation instructions similar to the installation instructions used to construct the test specimen. If one or more significant variations from the through-penetration firestop system listing instructions are used to construct the test specimen, the test results would not normally be considered to apply to the through-penetration firestop system that does not incorporate that particular installation technique. An example of a modification that would make the movement test non-applicable to the intended through-penetration firestop system listing would be the application of a releasing agent at the interface between a penetrating item and the adjacent firestop product, or between a penetrating item and the adjacent assembly, where the application of such a releasing agent is not part of the through-penetration firestop system listing or the manufacturer's installation instructions. A movement test that uses an ingredient that is not allowed by a listed through-penetration firestop system, or which omits an ingredient that is required by the referenced listed through-penetration firestop system, is not to be considered valid for ascertaining the movement capabilities of that listed through-penetration firestop system.

8.4.2 Through-penetration firestop systems that involve liquid-applied sealants shall allow the sealant(s) to cure in one of the following ways:

(a) for a period of 90 days in air having 40 % to 60 % relative humidity at  $73^\circ\text{F} \pm 5^\circ\text{F}$  ( $23^\circ\text{C} \pm 3^\circ\text{C}$ ), or

(b) for a period of four weeks in a heated chamber maintained at a temperature of  $100^\circ\text{F} \pm 5^\circ\text{F}$  ( $38^\circ\text{C} \pm 3^\circ\text{C}$ ), in air having 15 % to 35 % relative humidity.

NOTE 18—When desired by the test sponsor, curing shall be permitted via storage in a heated chamber. The curing of sealants is a particular concern for this test method, since under-cured materials will possibly allow for more movement without damage than they would after more

complete curing, thus over-representing the lifetime movement capabilities of the specific through-penetration firestop system.

**9. Test Procedure**

9.1 Maintain the laboratory at a temperature of 73 °F ± 7 °F (23 °C ± 4 °C).

9.2 Place the test specimen in the testing machine. Attach the penetrating item using hardware that:

- (a) allows the cyclic movement to occur without any slippage of the penetrating item from its attachment, and
- (b) maintains parallelism, and
- (c) has sufficient rigidity so that connection elements that are approximately perpendicular to each other shall remain at an angle of 90° ± 5° to each other before, during, and after cyclic testing.

9.3 Conduct two independent cycling tests. One shall be for movement sequence in the z-direction, and one for movement sequence in the y-direction.

9.4 After the cycling sequence in the z-direction is completed, test a new test specimen for cycling in the y-direction.

9.4.1 As an alternative procedure, when there is no damage observed on the z-direction test specimen and when agreed upon by the testing laboratory and the test sponsor, conduct the y-direction test on the test specimen initially tested in the z-direction.

9.5 *Movement Sequence in Direction Perpendicular to Face of Test Assembly (“z-direction”)*—Mount the test assembly in the test apparatus to allow the penetrating item to be moved in a direction perpendicular to the face of the test assembly with a defined load cycle sequence as shown in Table 2. It is permissible for the movement to be controlled either via programmable operation or via manual operation. One movement cycle includes moving the penetrant away from the zero position for the distance indicated in Table 2, returning to the zero position, moving the penetrant in the opposite direction for the distance indicated in Table 2, and then returning to the zero-position.

NOTE 19—This load cycle sequence is based on the load protocol

**TABLE 2 Displacement Sequence for Z-direction Movement Amplitude**

Repeats	Displacement (in.)
10	0.25
3	0.30
3	0.36
3	0.43
3	0.51
3	0.62
3	0.75
3	0.90
3	1.08
3	1.29
3	1.55
3	1.86
3	2.23
3	2.67
3	A

<sup>A</sup> Table may be extended indefinitely using Repeats = 3 and Displacement =  $D_s \times 1.2$  ( $D_s$  is displacement at last sequence).

specified in FEMA 461 for items susceptible to low-cycle fatigue failures.

9.6 *Movement Sequence in Direction Parallel to Face of Test Assembly (“y-direction”)*—Mount the test assembly in the test apparatus to allow the penetrating item to be moved in a direction parallel to the face of the test assembly with a defined load cycle sequence as shown in Table 1 in the y-direction. The movement in the y-direction shall be limited to no more than the length of the annular space. The movement shall be permitted to be controlled either via programmable operation or via manual operation. One movement cycle includes moving the penetrant away from the zero position for the distance indicated in Table 1, returning to the zero position, moving the penetrant in the opposite direction for the distance indicated in Table 1, and then returning to the zero-position.

NOTE 20—A y-direction movement exceeding the size of the annular space causes the penetrating item to impact the substrate, potentially damaging the penetrating item, or the substrate, or any combination of these components.

NOTE 21—This load cycle sequence is based on the load protocol specified in FEMA 461 for items susceptible to low-cycle fatigue failures.

9.7 Establish the cycling movement speed between 15 and 25 in./min. (381 mm/min. to 635 mm/min.), inclusive.

NOTE 22—The recommended cyclic movement speed target is 20 in./min (508 mm/min). The time taken for one complete cycle at the largest cycling distance in Table 2, 3.21 in. (82 mm), would therefore be approximately 30 s: From 0-position 7 s to the maximum displacement in one direction, hold for 1 s, 14 s to the maximum displacement in the opposite direction, hold for 1 s and 7 s back to 0-position. This allows the motion to be observed whether in person or via video recording, while being slow enough to allow manual cycling operation if programmable operation is not available.

9.8 It is permissible to pause the cycling movement sequence for up to 5 min after completing the repeats specified in Table 2 for any given displacement distance if the pause is required in order to properly evaluate and record damage in accordance with Section 10.

9.9 Terminate the movement test in each of the y-direction and z-direction at the maximum length of cyclic movement requested by the test sponsor. It is permissible for the maximum length of cyclic movement to be modified during the course of a test, to be either increased or decreased, as requested by the test sponsor.

9.10 Document the test observations in accordance with Section 10 after completing the required cyclic movement for each displacement distance.

9.11 After documenting the test observations in accordance with 9.10, conduct a fire resistance test agreed upon by the test sponsor and testing laboratory to determine each test specimen’s fire resistance rating.

NOTE 23—The selected fire test procedure will generally be a published test procedure acceptable to the Authority Having Jurisdiction where the tested through-penetration firestop systems are intended for installation. Examples of fire test procedures that are used for determining the fire resistance rating include, but are not limited to, EN 1366, ISO 834, Test Method E814, CAN/ULC-S115, UL 1479, IMO FTP Code, Test Methods E119, UL 263, and CAN/ULC-S101.

**10. Observations**

10.1 Upon completion of each length of cyclic movement when the penetrating item is returned to its original starting

position (the zero-position), visually inspect and document any changes to the firestop system, for example, cracks, separation from substrate, separation from penetrating item, and deformations. Describe the level of damage as follows:

- (a) No damage;
- (b) Gap or crack less than or equal to 0.08 in. (2 mm) in the smallest dimension, in which case the width of the cracks shall be measured with a feeler gauge, and the length shall be measured;
- (c) Opening greater than 0.08 in. (2 mm) in the smallest dimension, in which case the width and length of the opening shall be measured;
- (d) Deformation of the through-penetration firestop system, in which case the deformation will be described as completely as possible in the report; and
- (e) Total damage to the through-penetration firestop system, which would be any sort of catastrophic failure that would make it obvious that the firestopping function would be compromised to the point of being ineffective.

NOTE 24—Examples of “total damage” to the through-penetration firestop system would include an intumescent collar or wrap strip detaching from the test assembly; a block, plug or pillow falling out of the opening; a solid firestop device breaking open or breaking apart into multiple pieces; and sealant or putty falling completely out of the annular space.

10.2 Photograph each test specimen before and after each test. This allows “no damage” to be verified and the degree of damage to be documented. Additionally, photograph each specimen whenever any of the damage levels beyond “no damage” are recorded. Include a scale in these photographs so that dimensions can be established from the photos.

NOTE 25—Video footage is encouraged, as it can allow a post-test analysis of failure modes and other information.

10.3 Describe test specimens reaching a failure condition in detail, using photographs, if necessary, to clarify the descriptions.

## 11. Supplementary Tests

11.1 When requested by the test sponsor, conduct optional supplementary tests prior to the movement cycling test.

NOTE 26—An example of such a test is accelerated aging.

11.2 When requested by the test sponsor, conduct optional supplementary tests subsequent to the movement cycling test.

NOTE 27—Examples of such tests include an L-rating test in accordance with UL 1479, a W-rating test in accordance with UL 1479, or other tests as agreed upon by the testing laboratory and test sponsor.

11.3 When an optional test is conducted either prior to or after the movement test, clearly identify on the cover page of the test report that the overall test included more than the movement cycling specified by this standard prior to fire resistance testing.

NOTE 28—An example of a possible report title meeting this requirement would be “Movement cycling test of through-penetration firestop system in accordance with Test Method E3037, followed by testing in accordance with W-rating test procedure in accordance with UL 1479.”

11.4 Where an optional test is conducted either prior to or after the movement test, include in the test report a description

of the optional test conducted, either by reference to a published test procedure or test standard, or by including a complete description of the optional test.

## 12. Report

12.1 Report the following information:

12.1.1 Test date and report number,

12.1.2 Testing agency, address, and phone number, and

12.1.3 Length of time allowed for curing between product installation and the test date, as well as the manufacturer’s instructions’ curing time for comparison.

12.1.4 *Test Assembly Identification:*

12.1.4.1 All materials used to create the test assembly, and their configuration.

NOTE 29—When applicable to a product, include material, material source (manufacturer’s name and address), product name or designation, length, width, height, gauge, density, reinforcement and weight, etc. When a test assembly has a recognized Listing state the Listing designation and source.

12.1.5 *Firestop Material Identification:*

12.1.5.1 Material or device types and product names,

12.1.5.2 Batch number of all firestop products used,

12.1.5.3 Firestop material manufacturer’s name and address,

12.1.5.4 Material listings from third party organizations, the listing designations (for example, number), and listing source or sources, and

NOTE 30—“Listings” have different designations at different organizations, for example, certification, classification, technical evaluation, and approval.

12.1.5.5 Description of the quantity of material used, using appropriate units for each material (for example, thickness of sealant installed, number of layers of intumescent wrap strips).

12.1.6 *Penetrating Item Identification:*

12.1.6.1 Details to allow an independent party to specify items having the same relevant properties, and to configure those items in a test specimen in the same way.

12.1.7 Other pertinent data.

12.1.8 *Detailed Cross Sectional Test Specimen Drawings and Photographs of:*

12.1.8.1 Test assembly (8.1),

12.1.8.2 Penetrating items (8.2),

12.1.8.3 Penetrating item support (8.3), and

12.1.8.4 Through-penetration firestop system (8.4).

12.1.9 Detailed plan view, including component identification and material composition.

12.1.10 Manufacturer’s instructions in 8.4.1 and 12.1.3.

12.1.11 If modifications are made to the through-penetration firestop system, which deviate from a tested and listed through-penetration firestop system that is to be used as a fire test reference, the modifications to the system shall be reported.

NOTE 31—The types of modifications anticipated would be modifications that would minimally affect the fire rating, but which might significantly impact the movement capability of the through-penetration firestop system.

12.1.12 Method of determining the gap, crack, and opening dimensions specified in 10.1.