



Designation: F2977 – 20

# Standard Test Method for Small Punch Testing of Polymeric Biomaterials Used in Surgical Implants<sup>1</sup>

This standard is issued under the fixed designation F2977; the number immediately following the designation indicates the year of original adoption or, in the case of revision, the year of last revision. A number in parentheses indicates the year of last reapproval. A superscript epsilon ( $\epsilon$ ) indicates an editorial change since the last revision or reapproval.

## 1. Scope

1.1 This test method covers the determination of mechanical behavior of polymeric biomaterials by small punch testing of miniature disk specimens (0.5 mm in thickness and 6.4 mm in diameter). The test method has been established for characterizing surgical materials after ram extrusion or compression molding (**1-3**)<sup>2</sup>; for evaluating as-manufactured implants and sterilization method effects (**4, 5**); as well as for testing of implants that have been retrieved (explanted) from the human body (**6, 7**).

1.2 The results of the small punch test, namely the peak load, ultimate displacement, ultimate load, and work to failure, provide metrics of the yielding, ultimate strength, ductility, and toughness under multiaxial loading conditions. Because the mechanical behavior can be different when loaded under uniaxial and multiaxial loading conditions (**8**), the small punch test provides a complementary mechanical testing technique to the uniaxial tensile test. However, it should be noted that the small punch test results may not correlate with uniaxial tensile test results.

1.3 In addition to its use as a research tool in implant retrieval analysis, the small punch test can be used as a laboratory screening test to evaluate new materials with minimal material waste (**1**).

1.4 The small punch test has been applied to other polymers, including polymethyl methacrylate (PMMA) bone cement, polyacetal, and high density polyethylene (HDPE), ultra high molecular weight polyethylene (UHMWPE), and polyetheretherketone (PEEK) (**2, 3, 5, 9, 10**). This standard outlines general guidelines for the small punch testing of implantable polymers.

1.5 *This standard does not purport to address all of the safety concerns, if any, associated with its use. It is the*

*responsibility of the user of this standard to establish appropriate safety, health, and environmental practices and determine the applicability of regulatory limitations prior to use.*

1.6 *This international standard was developed in accordance with internationally recognized principles on standardization established in the Decision on Principles for the Development of International Standards, Guides and Recommendations issued by the World Trade Organization Technical Barriers to Trade (TBT) Committee.*

## 2. Referenced Documents

2.1 *ASTM Standards*:<sup>3</sup>

D695 Test Method for Compressive Properties of Rigid Plastics

D883 Terminology Relating to Plastics

E4 Practices for Force Verification of Testing Machines

E83 Practice for Verification and Classification of Extensometer Systems

E177 Practice for Use of the Terms Precision and Bias in ASTM Test Methods

E691 Practice for Conducting an Interlaboratory Study to Determine the Precision of a Test Method

F1714 Guide for Gravimetric Wear Assessment of Prosthetic Hip Designs in Simulator Devices

F1715 Guide for Wear Assessment of Prosthetic Knee Designs in Simulator Devices (Withdrawn 2006)<sup>4</sup>

F2003 Practice for Accelerated Aging of Ultra-High Molecular Weight Polyethylene after Gamma Irradiation in Air

F2102 Guide for Evaluating the Extent of Oxidation in Polyethylene Fabricated Forms Intended for Surgical Implants

## 3. Terminology

3.1 *Definitions*:

<sup>1</sup> This test method is under the jurisdiction of ASTM Committee F04 on Medical and Surgical Materials and Devices and is the direct responsibility of Subcommittee F04.15 on Material Test Methods.

Current edition approved April 1, 2020. Published June 2020. Originally approved in 2013. Last previous edition approved in 2013 as F2977–13<sup>ε1</sup>. DOI: 10.1520/F2977-20.

<sup>2</sup> The boldface numbers in parentheses refer to the list of references at the end of this standard.

<sup>3</sup> For referenced ASTM standards, visit the ASTM website, www.astm.org, or contact ASTM Customer Service at service@astm.org. For *Annual Book of ASTM Standards* volume information, refer to the standard's Document Summary page on the ASTM website.

<sup>4</sup> The last approved version of this historical standard is referenced on www.astm.org.

3.1.1 *small punch test, n*—a test wherein the specimen is of miniature size relative to conventional mechanical test specimens, is disk-shaped, and is loaded axisymmetrically in bending by a hemispherical-head punch.

NOTE 1—The features of a typical small punch test load versus displacement curve for PEEK, UHMWPE, and PMMA bone cement are illustrated in Fig. 1(a-c) and Fig. 2.

3.2 *Definitions of Terms Specific to This Standard:*

3.2.1 *peak load, n*—an initial local maximum in the load versus displacement curve (Fig. 2). In certain polymer formulations such as radiation crosslinked UHMWPE materials, the load versus displacement curve increases monotonically and a shoulder, rather than an initial peak load, may be observed. For brittle materials, the load versus displacement behavior may be completely linear, in which case no peak load would be observed.

3.2.2 *ultimate load, n*—the load at rupture (failure) of the specimen that is calculated at the first point before the breaking point in the curve where the root of the first derivative is equal to zero (Fig. 2).

3.2.3 *ultimate displacement, n*—the displacement at rupture (failure) of the specimen (Fig. 2).

3.2.4 *work to failure, n*—the area under the load versus displacement curve (Fig. 2).

4. Significance and Use

4.1 Miniature specimen testing techniques are used to characterize the mechanical behavior of polymer stock materials and surgical implants after manufacture, sterilization, shelf aging, radiation crosslinking, thermal treatment, filler

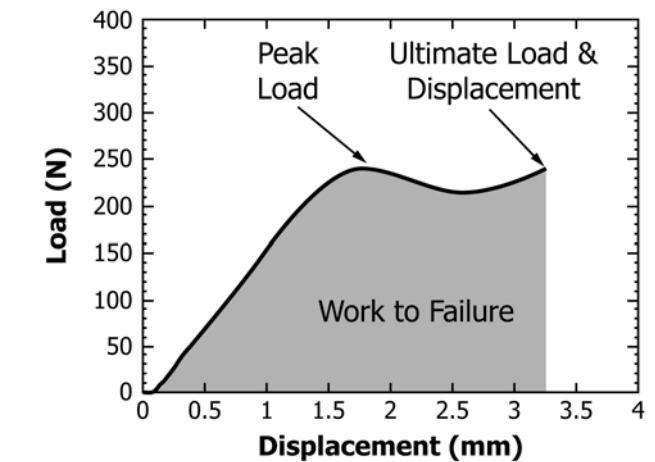

FIG. 2 Features of the small punch test load versus displacement curve for PEEK, including the peak load, ultimate load & displacement, and work to failure

incorporation, and implantation (1-3). Furthermore, experimental materials can be evaluated after accelerated aging, fatigue testing, and hip, knee, or spine wear simulation. Consequently, the small punch test makes it possible to examine relationships between wear performance and mechanical behavior. This test method can also be used to rank the mechanical behavior relative to a reference control material.

4.2 Small punch testing results may vary with specimen preparation and with the speed and environment of testing. Consequently, where precise comparative results are desired, these factors must be carefully controlled.

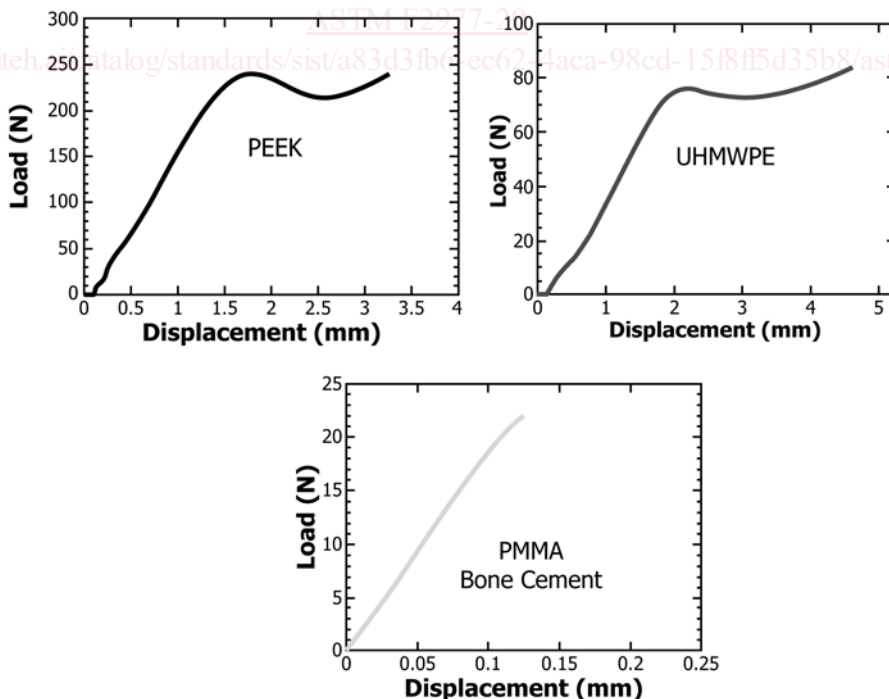

FIG. 1 Representative load versus displacement curves for (a) PEEK, (b) UHMWPE, and (c) PMMA bone cement. Note that the vertical axis is different for each of these materials

5. Apparatus

5.1 *Small Punch Test Apparatus*—A system consisting of a hemispherical head punch, a die, and a guide for the punch, as shown in Fig. 3. The parts shall be fabricated from a hardened steel.

5.1.1 *Guide*—The function of the guide is to align the punch relative to the specimen, which rests in a disk-shaped recess. The inner diameter of the guide bore shall be  $0.1010 + 0.0002/-0.0000$  in. ( $2.565 + 0.005/0.000$  mm), and the *specimen recess* shall be  $0.0200 + 0.0004/-0.0000$  in. ( $0.508 + 0.010/-0.000$  mm) in depth and  $0.2520 \pm 0.0005$  in. ( $6.401 \pm 0.013$  mm) in diameter.

5.1.2 *Die*—The function of the die is to constrain the sample during testing. The inner diameter of the die bore shall be  $0.1500 \pm 0.0005$  in. ( $3.810 \pm 0.013$  mm).

5.1.3 *Punch*—The hemispherical head punch shall have a diameter of 0.1000 in. (2.540 mm), with a tolerance of  $+0.0000/-0.0002$  in. ( $+0.000/-0.005$  mm).

5.2 *Testing Machine*—Any suitable testing machine as described in Method D695, consisting of a drive mechanism and a load indicator. A load cell should be used in which the peak load and ultimate load fall within the 10-90% capacity of the equipment. The accuracy of the machine shall be verified at least once per year, as specified by Method D695 and Practice E4.

5.3 *Compressometer*—This instrument, described in section 5.2 from Method D695, can be used to determine the distance between the die and the punch during the test. If the actuator displacement of the testing machine can be shown to determine punch displacement within 1% of the value measured by a suitably calibrated compressometer (as defined in Practice E83), actuator displacement shall be used as reference.

5.4 *Compression Platen*—The punch shall rest on a compression platen or tool for applying the load to the punch.

5.5 *Micrometers*—Suitable micrometers, reading to 0.0001 in. (0.0025 mm), shall be used to record the diameter and thickness of the specimens.

5.6 *Thermometer*—Suitable thermometer or thermocouple, reading to 0.1°C, shall be used to record the test temperature within the range 20° to 24°C.

6. Test Specimens

6.1 As the test results are known to be sensitive to preparation technique, the specimens described in 6.2 and 6.3 shall be used. The specimens may be prepared by machining operations from materials in sheet, rod, plate, or implant form. All machining operations shall be done carefully so that smooth surfaces result. Great care shall be taken in machining the faces so that smooth, parallel surfaces result.

NOTE 2—Although specimen fabrication methods other than machining (e.g., microtoming) may be used, the use of alternate specimen preparation methods have not yet been shown to provide equivalent test results to machined specimens.

6.2 If specimens are prepared from stock materials, the orientation of the test specimen with respect to the manufacturing direction (e.g., perpendicular to the extrusion or compression molding axis) shall be recorded, along with the distance from the surface of the stock material. If the specimens are machined directly from actual implants, the orientation and depth from the articulating surface shall be recorded.

6.3 The standard test specimen shall have a thickness of  $0.0200 + 0.0002/-0.0003$  in. ( $0.508 + 0.005/-0.008$  mm) and a diameter of  $0.250 + 0.000/-0.005$  in. ( $6.350 + 0.000/-0.127$  mm). For comparisons made at a single institution, alternate sample geometry may be specified. However, the results from that institution will likely not be comparable to the results from other institutions.

6.4 Specimens falling outside the dimensional tolerances specified in 6.3 shall be discarded.

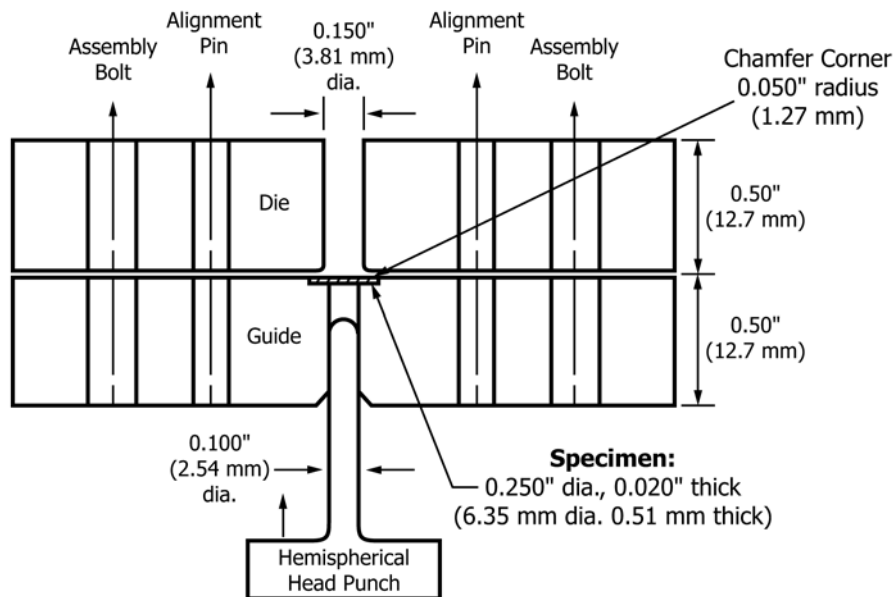

FIG. 3 Schematic of the small punch test apparatus, including the die, guide, hemispherical head punch, and miniature disk shaped specimen