



Designation: **C143/C143M – 15a** C143/C143M – 20

## Standard Test Method for Slump of Hydraulic-Cement Concrete<sup>1</sup>

This standard is issued under the fixed designation C143/C143M; the number immediately following the designation indicates the year of original adoption or, in the case of revision, the year of last revision. A number in parentheses indicates the year of last reapproval. A superscript epsilon ( $\epsilon$ ) indicates an editorial change since the last revision or reapproval.

*This standard has been approved for use by agencies of the U.S. Department of Defense.*

### 1. Scope\*

1.1 This test method covers determination of slump of hydraulic-cement concrete, both in the laboratory and in the field.

1.2 The values stated in either SI units or inch-pound units are to be regarded separately as standard. Within the text, the SI units are shown in brackets. The values stated in each system ~~may~~ are not necessarily exact equivalents; therefore, to ensure conformance with the standard, each system shall be used independently of the other. ~~Combining~~ other, and values from the two systems ~~may result in non-conformance with the standard.~~ shall not be combined.

1.3 The text of this standard ~~references~~ refers to notes and footnotes ~~which~~ that provide explanatory material. These notes and footnotes (excluding those in tables and figures) shall not be considered as requirements of ~~the~~ this standard.

1.4 *This standard does not purport to address all of the safety concerns, if any, associated with its use. It is the responsibility of the user of this standard to establish appropriate safety, health, and ~~health~~ environmental practices and determine the applicability of regulatory limitations prior to use. (Warning—Fresh hydraulic cementitious mixtures are caustic and may cause chemical burns to skin and tissue upon prolonged exposure.)*

1.5 *This international standard was developed in accordance with internationally recognized principles on standardization established in the Decision on Principles for the Development of International Standards, Guides and Recommendations issued by the World Trade Organization Technical Barriers to Trade (TBT) Committee.*

### 2. Referenced Documents

2.1 *ASTM Standards:*<sup>3</sup>

C31/C31M Practice for Making and Curing Concrete Test Specimens in the Field

C138/C138M Test Method for Density (Unit Weight), Yield, and Air Content (Gravimetric) of Concrete

~~C172/C172M~~ Practice for Sampling Freshly Mixed Concrete ~~C143M-20~~

C173/C173M Test Method for Air Content of Freshly Mixed Concrete by the Volumetric Method /astm-c143-c143m-20

~~C231/C231M~~ Test Method for Air Content of Freshly Mixed Concrete by the Pressure Method

C670 Practice for Preparing Precision and Bias Statements for Test Methods for Construction Materials

D638 Test Method for Tensile Properties of Plastics

### 3. Summary of Test Method

3.1 A sample of freshly mixed concrete is placed and compacted by rodding in a mold shaped as the frustum of a cone. The mold is raised, and the concrete allowed to subside. The vertical distance between the original and displaced position of the center of the top surface of the concrete is measured and reported as the slump of the concrete.

### 4. Significance and Use

4.1 This test method is intended to provide the user with a procedure to determine slump of plastic hydraulic-cement concretes.

NOTE 1—This test method was originally developed to provide a technique to monitor the consistency of unhardened concrete. Under laboratory

<sup>1</sup> This test method is under the jurisdiction of ASTM Committee C09 on Concrete and Concrete Aggregates and is the direct responsibility of Subcommittee C09.60 on Testing Fresh Concrete.

Current edition approved Dec. 15, 2015; June 1, 2020. Published February 2016; July 2020. Originally approved in 1922. Last previous edition approved in 2015 as C143/C143M – 15; C143/C143M – 15a. DOI: 10.1520/C0143-C0143M-15A10.1520/C0143-C0143M-20.

<sup>2</sup> Section on Safety Precautions, Manual of Aggregate and Concrete Testing, *Annual Book of ASTM Standards*, Vol. 04.02, Section on Safety Precautions, Manual of Aggregate and Concrete Testing, *Annual Book of ASTM Standards*, Vol 04.02.

<sup>3</sup> For referenced ASTM standards, visit the ASTM website, www.astm.org, or contact ASTM Customer Service at service@astm.org. For *Annual Book of ASTM Standards* volume information, refer to the ~~standard's~~ standard's Document Summary page on the ASTM website.

\*A Summary of Changes section appears at the end of this standard

conditions, with strict control of all concrete materials, the slump is generally found to increase proportionally with the water content of a given concrete mixture, and thus to be inversely related to concrete strength. Under field conditions, however, such a strength relationship is not clearly and consistently shown. Care should therefore be taken in relating slump results obtained under field conditions to strength.

4.2 This test method is considered applicable to plastic concrete having coarse aggregate up to 1½ in. [37.5 mm] in size. If the coarse aggregate is larger than 1½ in. [37.5 mm] in size, the test method is applicable when it is performed on the fraction of concrete passing a 1½-in. [37.5-mm] sieve, with the larger aggregate being removed in accordance with the section titled “Additional Procedure for Large Maximum Size Aggregate Concrete” in Practice C172/C172M.

4.3 This test method is not considered applicable to non-plastic and non-cohesive concrete.

NOTE 2—Concretes having slumps less than ½ in. [15 mm] may not be adequately plastic and concretes having slumps greater than about 9 in. [230 mm] may not be adequately cohesive for this test to have significance. Caution should be exercised in interpreting such results.

5. Apparatus

5.1 *Mold*—The test specimen shall be formed in a mold made of metal or plastic not readily attacked by the cement paste. The mold shall be sufficiently rigid to maintain the specified dimensions and tolerances during use, resistant to impact forces, and shall be non-absorbent. Metal molds shall have an average thickness of not less than 0.060 in. [1.5 mm] with no individual thickness measurement less than 0.045 in. [1.15 mm]. Plastic molds shall be ABS plastic or equivalent (Note 3) with a minimum average wall thickness of 0.125 in. [3 mm], with no individual thickness measurement less than 0.100 in. [2.5 mm]. The manufacturer or supplier shall certify the materials used in mold construction are in compliance with the requirements of this test method. The mold shall be in the form of the lateral surface of the frustum of a cone with the base 8 in. [200 mm] in diameter, the top 4 in. [100 mm] in diameter, and the height 12 in. [300 mm]. Individual diameters and heights shall be within ± ⅛ in. [3 mm] of the prescribed dimensions. The base and the top shall be open and parallel to each other and at right angles to the axis of the cone. The mold shall be provided with foot pieces and handles similar to those shown in Fig. 1. The mold shall be constructed without a seam. The interior of the mold shall be relatively smooth and free from projections. The mold shall be free from dents, deformation, or adhered mortar. A mold which clamps to a nonabsorbent base plate is acceptable instead of the one illustrated, provided the clamping arrangement is such that it can be fully released without movement of the mold and the base is large enough to contain all of the slumped concrete in an acceptable test.

NOTE 3—ABS (Acrylonitrile Butadiene Styrene) plastic exhibits the following minimum mechanical properties:

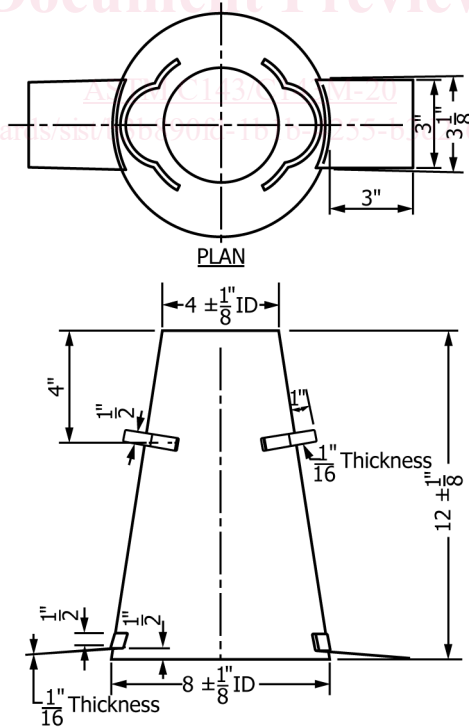

		Dimensional Units								
in.	1/16	1/8	1/2	1	3	3 1/2	4	8	12	
mm	[2]	[3]	[15]	[25]	[75]	[80]	[100]	[200]	[300]	

FIG. 1 Mold for Slump Test



Tensile modulus of elasticity, at 73 °F [23 °C]	320 000 psi	[2206 MPa]
Tensile strength (Test Method <b>D638</b> )	5670 psi	[39 MPa]
Percent Elongation at Break, at 73 °F [23 °C]	40%	
Percent Elongation at Break, at 73 °F [23 °C]	40 %	

5.1.1 Check and record conformance to the mold's specified dimensions when it is purchased or first placed in service and at least annually thereafter. To measure the top diameter, bottom diameter, and height, perform two measurements for each, approximately 90° apart, and record the results of each measurement. To verify mold thickness, perform two measurements approximately 180° apart at 1 ± ½ in. [25 ± 10 mm] from the top of the mold, two measurements approximately 180° apart at 1 ± ½ in. [25 ± 10 mm] from the bottom of the mold, and calculate the average of the four measurements.

5.2 *Tamping Rod*—A round, smooth, straight steel rod, with a 5/8 in. [16 mm] ± 1/16 in. [2 mm] diameter. The length of the tamping rod shall be at least 4 in. [100 mm] greater than the depth of the mold in which rodding is being performed, but not greater than 24 in. [600 mm] in overall length (Note 4). The rod shall have the tamping end or both ends rounded to a hemispherical tip of the same diameter as the rod.

NOTE 4—A rod length of 16 in. [400 mm] to 24 in. [600 mm] meets the requirements of the following: Practice **C31/C31M**, Test Method **C138/C138M**, Test Method **C143/C143M**, Test Method **C173/C173M**, and Test Method **E23/C231/C231M**.

5.3 *Measuring Device*—A ruler, metal roll-up measuring tape, or similar rigid or semi-rigid length measuring instrument marked in increments of ¼ in. [5 mm] or smaller. The instrument length shall be at least 12 in. [300 mm].

5.4 *Scoop*—of a size large enough so each amount of concrete obtained from the sampling receptacle is representative and small enough so it is not spilled during placement in the mold.

## 6. Sample

6.1 The sample of concrete from which test specimens are made shall be representative of the entire batch. It shall be obtained in accordance with Practice **E172/C172/C172M**.

## 7. Procedure

7.1 Dampen the mold and place it on a rigid, flat, level, moist, nonabsorbent surface, free of vibration, and that is large enough to contain all of the slumped concrete. It shall be held firmly in place during filling and perimeter cleaning by the operator standing on the two foot pieces or by a clamping arrangement to a base plate as described in 5.1. From the sample of concrete obtained in accordance with Section 6, immediately fill the mold in three layers, each approximately one third the volume of the mold (See Note 5). Place the concrete in the mold using the scoop described in 5.4. Move the scoop around the perimeter of the mold opening to ensure an even distribution of the concrete with minimal segregation.

NOTE 5—One third of the volume of the slump mold fills it to a depth of 2 5/8 in. [70 mm]; two thirds of the volume fills it to a depth of 6 1/8 in. [160 mm].

7.2 Rod each layer 25 times uniformly over the cross section with the rounded end of the rod. For the bottom layer, this will necessitate inclining the rod slightly and making approximately half of the strokes near the perimeter, and then progressing with vertical strokes spirally toward the center. Rod the bottom layer throughout its depth. For each upper layer, allow the rod to penetrate through the layer being rodded and into the layer below approximately 1 in. [25 mm].

7.3 In filling and rodding the top layer, heap the concrete above the mold before rodding is started. If the rodding operation results in subsidence of the concrete below the top edge of the mold, add additional concrete to keep an excess of concrete above the top of the mold at all times. After the top layer has been rodded, strike off the surface of the concrete by means of a screeding and rolling motion of the tamping rod. Continue to hold the mold down firmly and remove concrete from the area surrounding the base of the mold to preclude interference with the movement of slumping concrete. Remove the mold immediately from the concrete by raising it carefully in a vertical direction. Raise the mold a distance of 12 in. [300 mm] in 5 ± 2 s by a steady upward lift with no lateral or torsional motion. Complete the entire test from the start of the filling through removal of the mold without interruption and complete it within an elapsed time of 2 ½ min.

7.4 Immediately measure the slump by determining the vertical difference between the top of the mold and the displaced original center of the top surface of the specimen. If a decided falling away or shearing off of concrete from one side or portion of the mass occurs (Note 6), disregard the test and make a new test on another portion of the sample.

NOTE 6—If two consecutive tests on a sample of concrete show a falling away or shearing off of a portion of the concrete from the mass of the specimen, the concrete probably lacks necessary plasticity and cohesiveness for the slump test to be applicable.

## 8. Report

8.1 Report the slump in terms of inches [millimetres] to the nearest ¼ in. [5 mm] of subsidence of the specimen during the test.