



Designation: ~~D4310~~—~~20~~ **D4310 – 20a**

Standard Test Method for Determination of Sludging and Corrosion Tendencies of Inhibited Mineral Oils¹

This standard is issued under the fixed designation D4310; the number immediately following the designation indicates the year of original adoption or, in the case of revision, the year of last revision. A number in parentheses indicates the year of last reapproval. A superscript epsilon (ϵ) indicates an editorial change since the last revision or reapproval.

1. Scope*

1.1 This test method covers and is used to evaluate the tendency of inhibited mineral oil based steam turbine lubricants and mineral oil based anti-wear hydraulic oils to corrode copper catalyst metal and to form sludge during oxidation in the presence of oxygen, water, and copper and iron metals at an elevated temperature. The test method is also used for testing circulating oils having a specific gravity less than that of water and containing rust and oxidation inhibitors.

NOTE 1—During round robin testing copper and iron in the oil, water and sludge phases were measured. However, the values for the total iron were found to be so low (that is, below 0.8 mg), that statistical analysis was inappropriate. The results of the cooperative test program are available (see Section 16).

1.2 This test method is a modification of Test Method D943 where the oxidation stability of the same kinds of oils is determined by following the acid number of oil. The number of test hours required for the oil to reach an acid number of 2.0 mg KOH/g is the *oxidation lifetime*.

1.3 Procedure A of this test method requires the determination and report of the weight of the sludge and the total amount of copper in the oil, water, and sludge phases. Procedure B requires the sludge determination only. The acid number determination is optional for both procedures.

1.4 The values stated in SI units are to be regarded as standard. No other units of measurement are included in this standard.

1.5 **WARNING**—Mercury has been designated by many regulatory agencies as a hazardous substance that can cause serious medical issues. Mercury, or its vapor, has been demonstrated to be hazardous to health and corrosive to materials. Use Caution when handling mercury and mercury-containing products. See the applicable product Safety Data Sheet (SDS) for additional information. The potential exists that selling mercury or mercury-containing products, or both, is prohibited by local or national law. Users must determine legality of sales in their location.

1.6 *This standard does not purport to address all of the safety concerns, if any, associated with its use. It is the responsibility of the user of this standard to establish appropriate safety, health, and environmental practices and determine the applicability of regulatory limitations prior to use.* For specific warning statements, see Section 7 and X1.1.5.

1.7 *This international standard was developed in accordance with internationally recognized principles on standardization established in the Decision on Principles for the Development of International Standards, Guides and Recommendations issued by the World Trade Organization Technical Barriers to Trade (TBT) Committee.*

2. Referenced Documents

2.1 ASTM Standards:²

A510 Specification for General Requirements for Wire Rods and Coarse Round Wire, Carbon Steel (Metric) A0510_A0510M

B1 Specification for Hard-Drawn Copper Wire

D664 Test Method for Acid Number of Petroleum Products by Potentiometric Titration

D874 Test Method for Sulfated Ash from Lubricating Oils and Additives

D943 Test Method for Oxidation Characteristics of Inhibited Mineral Oils

D1193 Specification for Reagent Water

¹ This test method is under the jurisdiction of ASTM Committee D02 on Petroleum Products, Liquid Fuels, and Lubricants and is the direct responsibility of Subcommittee D02.09.0C on Oxidation of Turbine Oils.

Current edition approved Jan. 1, 2020. Published February 2020. Originally approved in 1983. Last previous edition approved in 2015 as D4310 – 10 (2015); D4310 – 20. DOI: 10.1520/D4310-20.10.1520/D4310-20A.

² For referenced ASTM standards, visit the ASTM website, www.astm.org, or contact ASTM Customer Service at service@astm.org. For *Annual Book of ASTM Standards* volume information, refer to the standard's Document Summary page on the ASTM website.

*A Summary of Changes section appears at the end of this standard

[D3339 Test Method for Acid Number of Petroleum Products by Semi-Micro Color Indicator Titration](#)

[D4057 Practice for Manual Sampling of Petroleum and Petroleum Products](#)

[E1 Specification for ASTM Liquid-in-Glass Thermometers](#)

2.2 *Energy Institute Standard*.³

[Specification for IP Standard Thermometers](#)

2.3 *British Standard*.⁴

[BS 1829 Reference Tables for Iron v. Constantan Thermocouples](#)

3. Terminology

3.1 Definitions:

3.1.1 *sludge, n*—a precipitate or sediment from oxidized mineral oil and water.

4. Summary of Test Method

4.1 An oil sample is contacted with oxygen in the presence of water and an iron-copper catalyst at 95 °C for 1000 h. The weight of insoluble material is determined by vacuum filtration of the oxidation tube contents through 5 µm pore size filter disks. The total amount of copper in the oil, water, and sludge phases is also determined for Procedure A. Procedure B requires the sludge determination. The copper determination is not required. The acid number determination is optional for both procedures.

NOTE 2—Optionally, some operators may choose to: (1) assess the change in weight of the catalyst coil, or (2) determine the acid number at 1000 h, or both. The acid number may serve as a criterion to determine if measurement of insoluble material is warranted. Normally, further testing is not recommended on a highly oxidized oil (that is an oil which has attained an acid number >2.0 mg KOH/g). Instructions for these optional tests are not included in this test method.

5. Significance and Use

5.1 Insoluble material may form in oils that are subjected to oxidizing conditions.

5.2 Significant formation of oil insolubles or metal corrosion products, or both, during this test may indicate that the oil will form insolubles or corrode metals, or both, during field service. However, no correlation with field service has been established.

6. Apparatus

6.1 *Oxidation Cell*, of borosilicate glass, as shown in Fig. 1, consisting of a test tube, condenser, and oxygen delivery tube. The test tube has a calibration line at 300 mL (maximum error 1 mL), ± 1 mL. This calibration applies to the test tube without inserts alone using water at 20 °C.

6.2 *Heating Bath: Liquid Bath or Metal Block*, thermostatically controlled, capable of maintaining the oil sample in the oxidation cell at a temperature of 95 °C ± 0.2 °C, fitted with a suitable stirring device to provide a uniform temperature throughout the bath, and large enough to hold the desired number of oxidation cells immersed in the heating bath to a depth of 390 mm ± 10 mm and in the heating liquid itself to a depth of 355 mm ± 10 mm.

6.2.1 Studies have suggested that direct sunlight or artificial light may adversely influence the results of this test.⁵ To minimize effects of light exposure on the lubricant being tested, light shall be excluded from the lubricant by one or more of the following ways:

6.2.1.1 Use of heated liquid baths that are designed and constructed of metal, or combinations of metals and other suitable opaque materials, that prevent light from entering the test cell from the sides is preferred. If a *viewing window* is included in the design, this *viewing window* shall be fitted with a suitable opaque cover and be kept closed when no observation is being made.

6.2.1.2 If glass heating baths are used, the bath shall be wrapped with aluminum foil or other opaque material.

6.2.1.3 Bright light entering the test cell from directly overhead can be eliminated by use of an opaque shield.

6.3 *Flowmeter*, with a flow capacity of at least 3 L of oxygen/hour, and an accuracy of ±0.1 L/h.

6.4 *Heating Bath Thermometer*—ASTM Solvents Distillation Thermometer having a range from 72 °C to 126 °C and conforming to the requirements for Thermometer 40C as prescribed in Specification E1, or for Thermometer 70C as prescribed in Specifications for IP Standard Thermometers. Alternatively, temperature-measuring devices of equal or better accuracy may be used.

6.5 *Oxidation Cell Thermometer*, having a range from 80 °C to 100 °C, graduated in 0.1 °C, total length—250 mm, stem diameter—6.0 mm to 7.0 mm, calibrated for 76 mm immersion. Temperature measuring devices such as liquid-in-glass thermometers, thermocouples, or platinum resistance thermometers that provide equivalent or better accuracy and precision that cover the temperature range, may be used.

³ Available from Energy Institute, 61 New Cavendish St., London, W1G 7AR, U.K., <http://www.energyinst.org>.

⁴ Available from British Standards Institution (BSI), 389 Chiswick High Rd., London W4 4AL, U.K., <http://www.bsigroup.com>.

⁵ Supporting data (summary of the results of these studies) have been filed at ASTM International Headquarters and may be obtained by requesting Research Report RR:D02-1365.

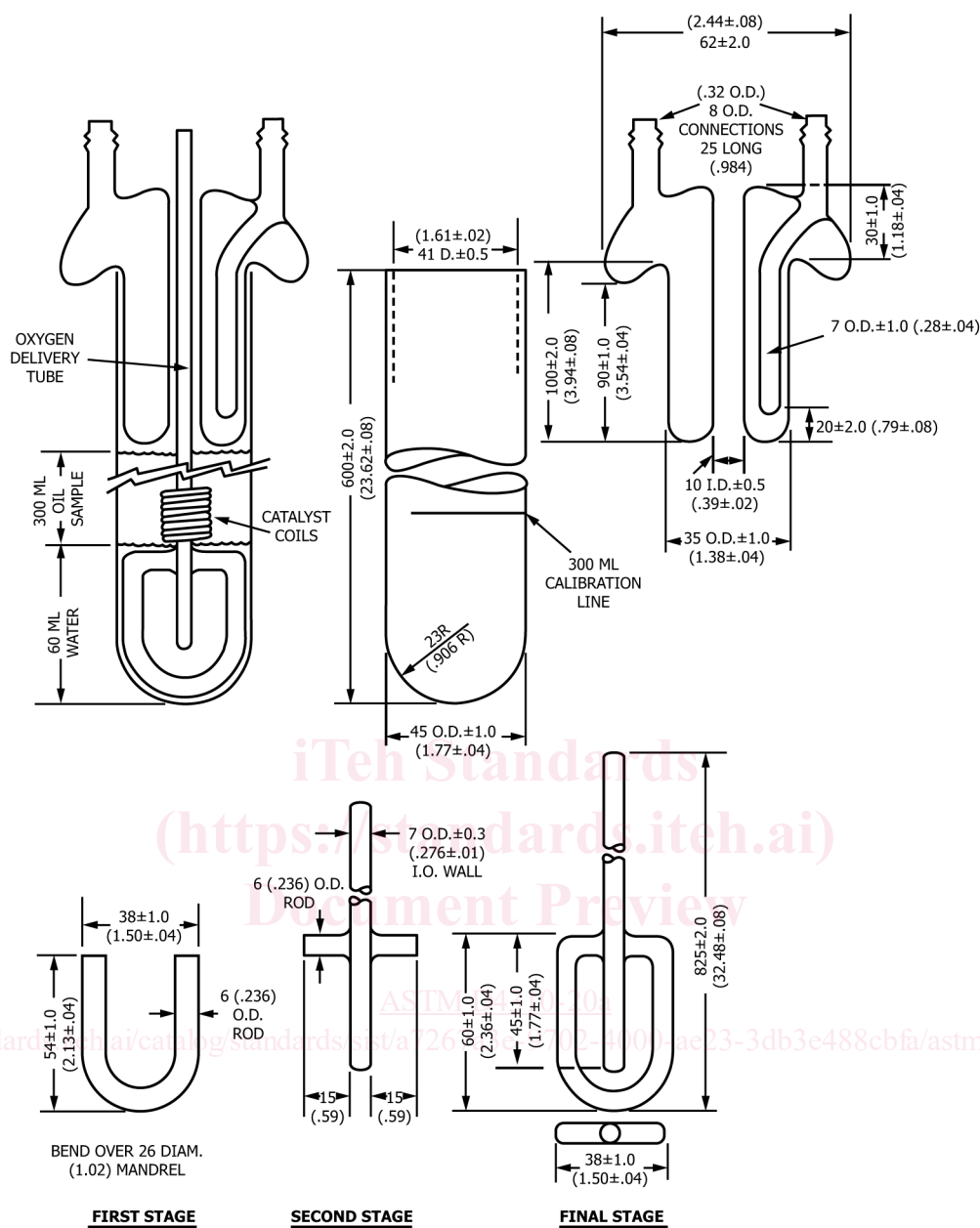

All dimensions are in millimetres (inches)

NOTE 1—The oxidation test tube has a calibration line at 300 mL. This calibration applies to the test tube alone at 20 °C.

NOTE 1—Open tube ends to be ground and fire-polished.

FIG. 1 Oxidation Cell

6.6 *Wire Coiling Mandrel*, as shown in Fig. 2.

6.7 *Thermometer Bracket—Optional*, for holding the oxidation cell thermometer, of 18-8 stainless steel, having the dimensions shown in Fig. 3. The thermometer is held in the bracket by two fluoro-elastomer O-rings of approximately 5 mm inside diameter. Alternatively, thin stainless steel wire may be used.

6.8 *Abrasive Cloth*, silicon carbide, 100-grit with cloth backing.

6.9 *Flexible Tubing*, poly vinyl chloride or fluoroelastomer copolymer⁶ approximately 6.4 mm (¼ in.) inside diameter with a 2.4 mm (¾ in.) wall for delivery of oxygen to the oxidation cell.

⁶ Fluoroelastomer copolymer is manufactured as Viton, a trademark owned by E. I. duPont de Nemours.

ASTM D4310 - 20a

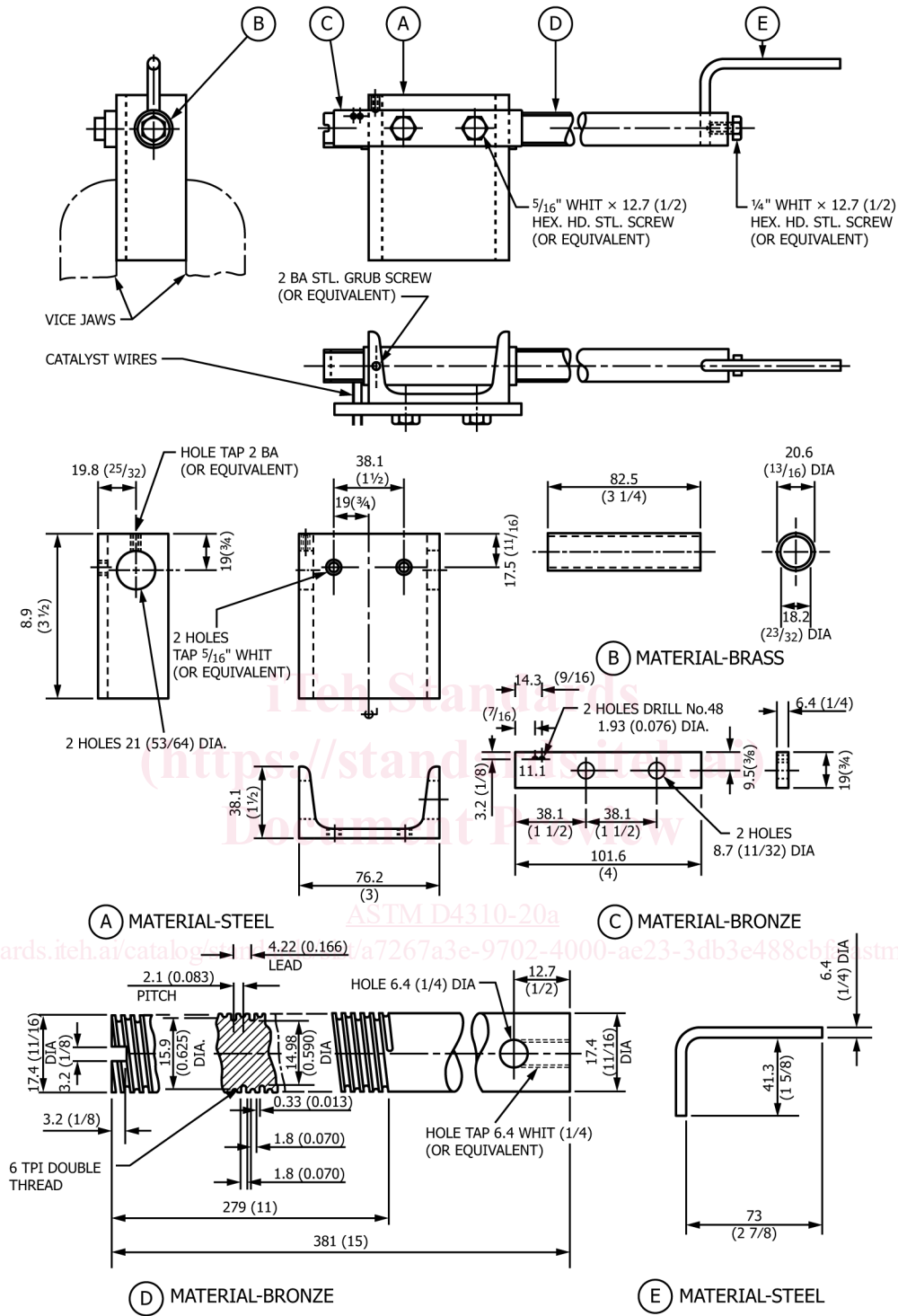

Dimensions are in millimetres (inches).

FIG. 2 Mandrel for Winding Catalyst Coils

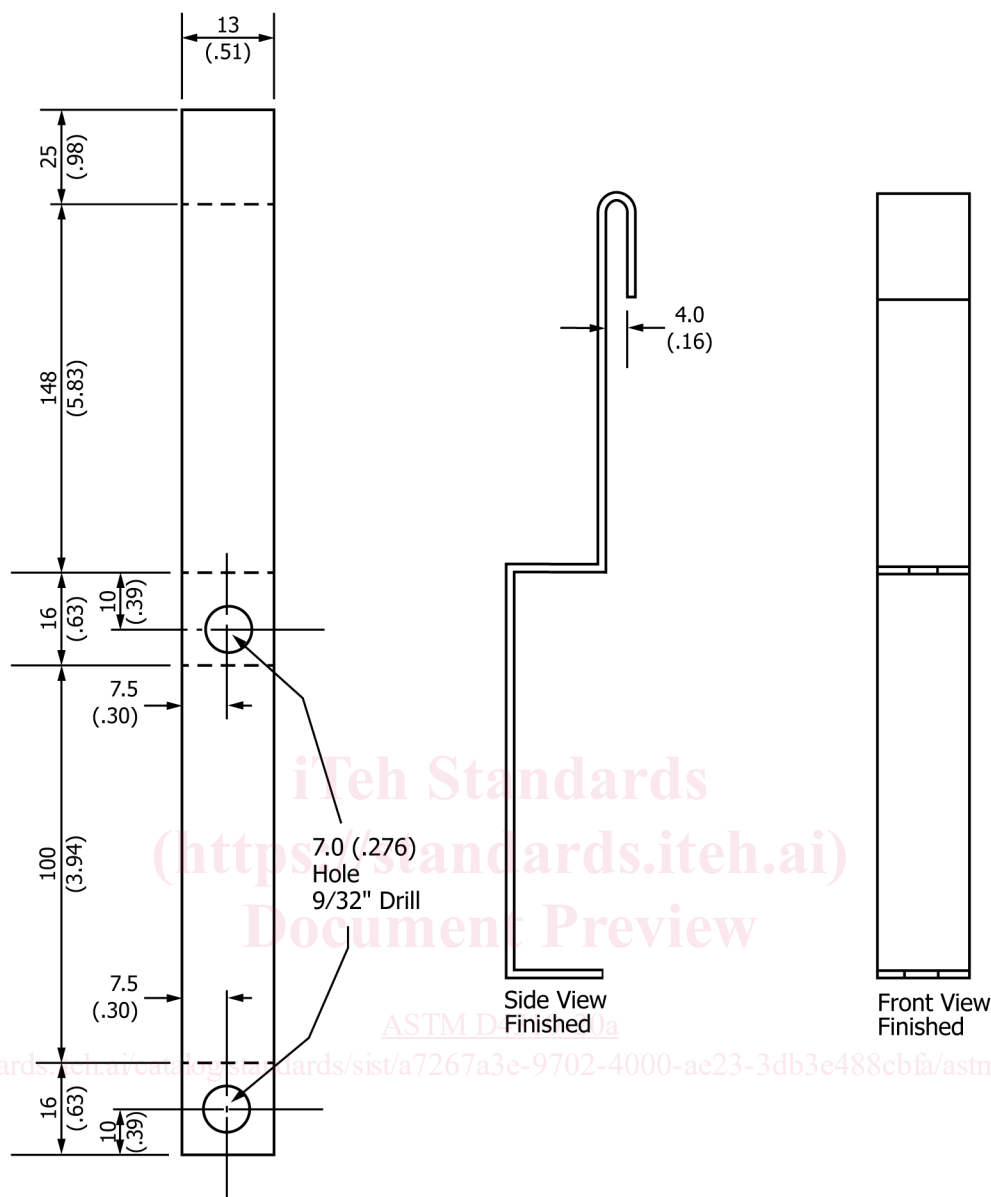

All dimensions are in millimetres (inches).
Material: 18-8 Stainless Steel. 22 Gauge (0.792 mm).

FIG. 3 Thermometer Bracket

6.10 *Membrane Filters*, ^{7,8} white, plain, 47 mm or 90 mm in diameter, pore size 5 μm .

6.11 *Filter Holder*, ^{7,9} 47 mm or 90 mm, consisting of a borosilicate glass funnel and a funnel base with a coarse grade (40 μm to 60 μm) fritted-glass filter support or stainless steel screen support such that the filter can be clamped between the ground-glass sealing surfaces of the funnel and its base by means of a metal clamp.

6.12 *Weighing Bottle*, ^{7,10} cylindrical body with ground-glass stopper; approximate inside diameter 45 mm, height of body 65 mm, capacity 60 mL.

6.13 *Vacuum Source*, to provide pressure reduction to 13.3 kPa \pm 0.7 kPa (100 mm \pm 5 mm Hg) absolute pressure.

⁷ If you are aware of alternative suppliers, please provide this information to ASTM International Headquarters. Your comments will receive careful consideration at a meeting of the responsible technical committee,¹ which you may attend.

⁸ The sole source of supply of the Millipore SM membrane filters (MF-type, cellulose esters) known to the committee at this time is Millipore Filter Corp., Bedford, MA.

⁹ The sole source of supply of the Millipore Pyrex XX-10-047-00 or XX-10-047-30 filter holder known to the committee at this time is Millipore Filter Corp., Bedford, MA.

¹⁰ The sole source of supply of the Fisher 3-415 weighing bottle, size G, known to the committee at this time is Fisher Scientific Co., Pittsburgh, PA.

6.14 *Cooling Vessel*—A desiccator or other type of tightly covered vessel for cooling the weighing vessels before weighing. The use of a drying agent is not recommended.

6.15 *Drying Oven*, capable of maintaining a temperature of $105\text{ }^{\circ}\text{C} \pm 2\text{ }^{\circ}\text{C}$.

6.16 *Forceps*, having unserrated tips.

~~6.17 *Syringe*, 50 mL Luer-Lok with 12 in. needle.~~

6.17 *Separatory Funnels*, with a capacity of 1000 mL.

6.18 *Rubber Policeman*.

~~6.20 *Pipette Bulb*.~~

6.19 ~~*Syringe*~~, *Syringes*, glass or plastic, with Luer-Lok locking connector, ~~10 mL capacity for sampling connectors~~, 10 mL and 60 mL capacities for sampling, and water additions, respectively.

6.20 *Syringe Sampling Tube*, Grade 304 stainless steel tubing, 2.11 mm (0.083 in.) outside diameter, 1.60 mm (0.063 in.) inside diameter, $559\text{ mm} \pm 2\text{ mm}$ (~~24.0 in.~~ 22.0 in. $\pm 0.08\text{ in.}$) long, with one end finished at 90° and the other end fitted with a Luer-Lok female connector.

6.21 *Filter Flasks*, with a capacity of 1000 mL.

6.22 *Syringe Water Addition Tube*—Optional, $304.8\text{ mm} \pm 2\text{ mm}$ (12 in. $\pm 0.08\text{ in.}$) long, with one end fitted with a Luer-Lok female connector.

iTeh Standards (<https://standards.iteh.ai>) Document Preview

[ASTM D4310-20a](#)

<https://standards.iteh.ai/catalog/standards/sist/a7267a3e-9702-4000-ae23-3db3e488cbfa/astm-d4310-20a>

7. Reagents and Materials

7.1 *Purity of Reagents*—Reagent grade chemicals shall be used in all tests. Unless otherwise indicated, it is intended that all reagents conform to the specifications of the Committee on Analytical Reagents of the American Chemical Society where such specifications are available.¹¹ Other grades may be used, provided it is first ascertained that the reagent is of sufficiently high purity to permit its use without lessening the accuracy of the determination.

7.2 *Purity of Water*—Unless otherwise indicated, references to water shall be understood to mean reagent water as defined by Type II of Specification **D1193**.

7.3 *Acetone*—Reagent grade. (**Warning**—Health hazard, flammable.)

7.4 *Cleaning Reagent*, cleaning by a 24 h soak at room temperature in either Nochromix^{7,12} (**Warning**—Corrosive, health hazard) or in Micro^{7,13} solution.

7.5 *n-Heptane*—Reagent grade. (**Warning**—Flammable. Harmful if inhaled.)

7.6 *Hydrochloric Acid* (**Warning**—Toxic and corrosive.), concentrated [(36 % by mass (relative density 1.19)].

7.7 *Isopropyl Alcohol*—Reagent grade. (**Warning**—Flammable.)

7.8 *Catalyst Wires*:

7.8.1 *Low-Metalloid Steel Wire*, 1.59 mm (0.0625 in.) in diameter (No. 16 Washburn and Moen Gauge).

NOTE 3—Carbon steel wire, soft bright annealed and free from rust of Grade 1008 as described in Specification **A510** is satisfactory. Similar wire conforming to BS 1829, is also satisfactory. If these steels are not available, other equivalent steels may be used, provided they are found to be satisfactory in comparative tests using this Test Method D4310.

7.8.2 *Electrolytic Copper Wire*, 1.63 mm (0.064 in.) in diameter (No. 16 Imperial Standard Wire Gauge or No. 14 American Wire Gauge), 99.9 % purity, conforming to Specification **B1**. Soft copper wire of an equivalent grade may also be used.

NOTE 4—Alternatively, suitably prepared catalyst coils may be purchased from a supplier.

7.9 *Detergent*, water-soluble.^{7,14}

7.10 *Oxygen*—(**Warning**—Oxygen vigorously accelerates combustion) 99.5 % minimum purity, with pressure regulation adequate to maintain a constant flow of gas through the apparatus. The use of a two-stage pressure regulator on tank oxygen is recommended.

8. Sampling

8.1 Samples for this test can come from tanks, drums, small containers, or even operating equipment. Therefore, use the applicable apparatus and techniques described in Practice **D4057**.

8.2 For one single determination the minimum required sample size is 300 mL.

9. Preparation of Apparatus

9.1 *Cleaning Catalyst*—Immediately prior to winding a catalyst coil, clean a 3.00 m \pm 0.01 m length of iron wire and an equal length of copper wire with wads of absorbent cotton wet with *n*-heptane and follow by abrasion with abrasive cloth until a fresh metal surface is exposed. Then wipe with dry absorbent cotton until all loose particles of metal and abrasive have been removed. In subsequent operations handle the catalyst wires with clean gloves (cotton, rubber, or plastic) to prevent contact with the skin.

9.2 *Preparation of Catalyst Coil*—Twist the iron and copper wires tightly together at one end for three turns and then wind them simultaneously alongside each other on a threaded mandrel (see **Fig. 2**), inserting the iron wire in the deeper thread. Remove the coil from the mandrel, twist the free ends of the iron and copper wires together for three turns, and bend the twisted ends to conform to the shape of the spiral coil. The overall length of the finished coil should be 225 mm \pm 5 mm (8.9 in. \pm 0.2 in.). If necessary, the coil may be stretched to give the required length (**Note 4** and **Note 5**).

NOTE 5—The finished catalyst coil is a double spiral of copper and iron wire, 225 mm \pm 5 mm (8.9 in. \pm 0.2 in.) overall length and 15.9 mm to 16.5 mm (0.625 in. to 0.650 in.) inside diameter. The turns of wire are evenly spaced, and two consecutive turns of the same wire are 3.96 mm to 4.22 mm (0.156 in. to 0.166 in.) apart, center to center. The mandrel shown in **Fig. 2** is designed to produce such a coil. Using this mandrel, the iron wire is wound on a thread of 14.98 mm (0.590 in.) diameter, while the copper wire is wound on a thread of 15.9 mm (0.625 in.) diameter. The smaller diameter is to allow for “springback” of the steel wire after winding, so as to give 15.9 mm consistent inside diameter. Use of a very soft annealed steel wire may allow use of identical thread diameters for the two wires. Any arrangement that leads to the coil configuration described above is satisfactory.

¹¹ ACS Reagent Chemicals, Specifications and Procedures for Reagents and Standard-Grade Reference Materials, American Chemical Society, Washington, DC. For suggestions on the testing of reagents not listed by the American Chemical Society, see *Anal. Standards for Laboratory Chemicals*, BDH Ltd., Poole, Dorset, U.K., and the *United States Pharmacopeia and National Formulary*, U.S. Pharmacopeial Convention, Inc. (USPC), Rockville, MD.

¹² The sole source of supply of Nochromix known to the committee at this time is Godax Laboratories, Inc., 720-B Erie Avenue, Takoma Park, MD 20912.

¹³ The sole source of supply of Micro known to the committee at this time is International Products Corp., P.O. Box 70, Burlington, NJ 08016.

¹⁴ Alconox has been found satisfactory for this purpose.