



Designation: D3769 – 20

Standard Test Method for Microcellular Urethanes—High-Temperature Sag¹

This standard is issued under the fixed designation D3769; the number immediately following the designation indicates the year of original adoption or, in the case of revision, the year of last revision. A number in parentheses indicates the year of last reapproval. A superscript epsilon (ϵ) indicates an editorial change since the last revision or reapproval.

1. Scope*

1.1 This test method covers the procedure and apparatus for measuring high-temperature sag of microcellular urethane materials.

1.2 The values stated in SI units are to be regarded as standard.

1.3 *This standard does not purport to address all of the safety concerns, if any, associated with its use. It is the responsibility of the user of this standard to establish appropriate safety, health, and environmental practices and determine the applicability of regulatory limitations prior to use.*

NOTE 1—There is no known ISO equivalent to this standard.

1.4 *This international standard was developed in accordance with internationally recognized principles on standardization established in the Decision on Principles for the Development of International Standards, Guides and Recommendations issued by the World Trade Organization Technical Barriers to Trade (TBT) Committee.*

2. Referenced Documents

2.1 *ASTM Standards:*²

D883 Terminology Relating to Plastics

D3040 Practice for Preparing Precision Statements for Standards Related to Rubber and Rubber Testing (Withdrawn 1987)³

E145 Specification for Gravity-Convection and Forced-Ventilation Ovens

E456 Terminology Relating to Quality and Statistics

E691 Practice for Conducting an Interlaboratory Study to Determine the Precision of a Test Method

¹ This test method is under the jurisdiction of ASTM Committee D20 on Plastics and is the direct responsibility of Subcommittee D20.22 on Cellular Materials - Plastics and Elastomers.

Current edition approved July 1, 2020. Published July 2020. Originally approved in 1979. Last previous edition approved in 2015 as D3769 - 15. DOI: 10.1520/D3769-20.

² For referenced ASTM standards, visit the ASTM website, www.astm.org, or contact ASTM Customer Service at service@astm.org. For *Annual Book of ASTM Standards* volume information, refer to the standard's Document Summary page on the ASTM website.

³ The last approved version of this historical standard is referenced on www.astm.org.

E2935 Practice for Conducting Equivalence Testing in Laboratory Applications

3. Terminology

3.1 Terms used in this standard are defined in accordance with Terminology D883, unless otherwise specified. For terms relating to precision and bias and associated issues, the terms used in this standard are defined in accordance with Terminology E456.

4. Significance and Use

4.1 This test method is used to indicate the potential tendency of microcellular materials to deform during paint application in an assembly plant operation. Since a standard specimen is used, do not assume heat sag measurements to be exactly those which will occur on a part during or after the paint application and baking operation of an assembly process.

4.2 Before proceeding with this test method, reference shall be made to the specification of the material being tested. Any test specimen preparation, conditioning, or dimensions, or combination thereof, and testing parameters covered in the materials specification shall take precedence over those mentioned in these test methods. If there are no material specifications, then the default conditions apply.

NOTE 2—This test method is applicable to solid urethanes.

5. Apparatus

5.1 *Test Fixture*, capable of holding the specimens in a fixed cantilever position for the duration of the entire test procedure. The test fixture shall be constructed from a material such as aluminum or steel that exhibits a low coefficient of linear thermal expansion and therefore allows the test fixture's height to be considered constant through the test. See Fig. 1.

5.2 *Oven*, conforming to the specifications for a Type IA laboratory oven in accordance with Specification E145.

5.3 *Scaled Rule*, accurate to 1 mm.

5.4 *Thickness Indicator*, accurate to 0.03 mm.

5.5 *Base*, a flat, smooth surface free of any surface irregularities that would affect the height measurements. The base must be heat-resistant to the maximum temperature that the test fixtures will be exposed.

*A Summary of Changes section appears at the end of this standard

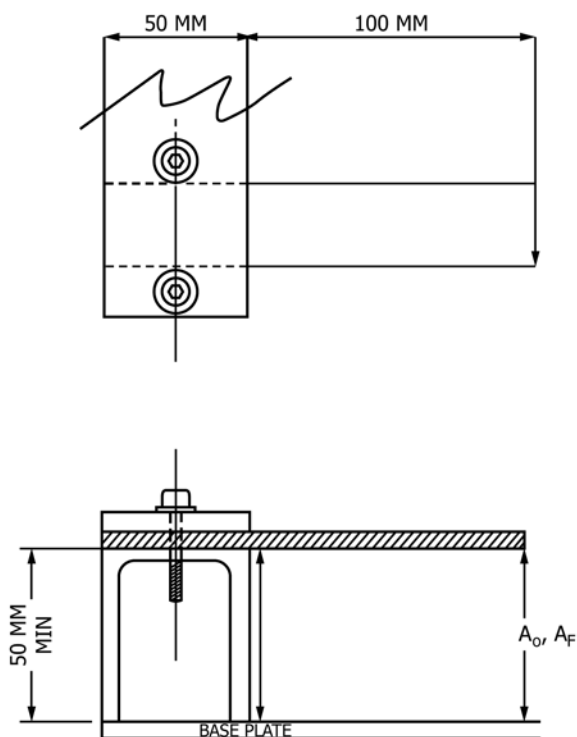

NOTE 1—Not to scale.

FIG. 1 Fixture for High-Temperature Sag

6. Test Specimens

6.1 The test specimen shall have a minimum length of 125 mm, and be 25 ± 1 mm in width by the nominal thickness of the plaque or part. The recommended standard test specimen is 4 mm in thickness. The minimum specimen thickness shall be 3 mm.

6.2 Three specimens to each material shall be tested.

NOTE 3—If test specimens are cut from parts, the specimens must be cut from areas that are of constant thickness; that is, no ribs, bosses, holes, or other section changes are allowed.

7. Conditioning

7.1 Unless otherwise specified, condition the specimens and fixture a minimum of 1 h at $23 \pm 2^\circ\text{C}$ and $50 \pm 10\%$ relative humidity before testing.

8. Procedure

8.1 Measure the thickness in the clamping area of the test specimen to the nearest 0.03 mm.

8.2 Clamp the specimen in the fixture with a 100 ± 1 mm unsupported overhang. Primed or painted surfaces are to be mounted facing up.

8.3 After 5 min, measure the distance between the base and the unsupported end of the specimen as shown in Fig. 1 and call this A_o .

8.4 Place the clamped specimen in an air-circulating oven at the test temperature of $120 \pm 1^\circ\text{C}$ for 60 ± 1 min.

8.5 After oven aging, remove the fixture with the specimen from the oven.

8.6 After 5 min, repeat the measurement as in 8.3 for A_o and call this distance A_f .

NOTE 4—Other combinations of test temperatures, test times, and overhang lengths are permitted subject to prior agreement between the test requestor and the testing facility. These conditions are to be included in the test report.

9. Calculation

$$9.1 \text{ Sag} = A_o - A_f$$

10. Report

10.1 The report shall include the following:

- 10.1.1 Direction of cutting,
- 10.1.2 Conditioning procedures before testing,
- 10.1.3 Time and temperature of the test,
- 10.1.4 Initial value at 23°C , average of three,
- 10.1.5 Final sag value at test temperature, average of three, and
- 10.1.6 Specimen thickness.

11. Precision and Bias

11.1 Table 1 is based on a round robin conducted in 1980 in accordance with Practice D3040, involving three materials tested by four laboratories. For each material, all the samples were prepared at one source and the individual specimens were also prepared at one source. Each test result consisted of one individual determination. Each laboratory obtained four test results for each material. (Warning—The data in Table 1 shall not be rigorously applied to acceptance or rejection of material, as those data are specific to the interlaboratory study and are not necessarily representative of other lots, conditions, materials, or laboratories. Users of this test method shall apply the principles outlined in Practice E691 to generate data specific to their laboratory and materials, or between specific laboratories.)

11.2 There are no recognized standards by which to estimate bias of this test method.

NOTE 5—When this round robin was performed, this method fell under the jurisdiction of ASTM Committee D11 on Rubber and Rubber-like Materials. The research report for the round robin was subsequently filed with Committee D20 and has the File No. D20-1191.⁴

12. Keywords

12.1 deformation; heat sag; high-temperature; microcellular; sag; urethane

⁴ Supporting data have been filed at ASTM International Headquarters and may be obtained by requesting Research Report RR:D20-1191. Contact ASTM Customer Service at service@astm.org.