



Designation: C1006/C1006M – 20a

Standard Test Method for Splitting Tensile Strength of Masonry Units¹

This standard is issued under the fixed designation C1006/C1006M; the number immediately following the designation indicates the year of original adoption or, in the case of revision, the year of last revision. A number in parentheses indicates the year of last reapproval. A superscript epsilon (ϵ) indicates an editorial change since the last revision or reapproval.

1. Scope*

1.1 This test method covers the determination of the splitting tensile strength of masonry units.

1.2 *Units*—The values stated in either SI units or inch-pound units are to be regarded separately as standard. The values stated in each system may not be exact equivalents; therefore, each system shall be used independently of the other. Combining values from the two systems may result in non-conformance with the standard.

1.3 The text of this standard references notes and footnotes that provide explanatory material. These notes and footnotes (excluding those in tables and figures) shall not be considered as requirements of the standard.

1.4 *This standard does not purport to address all of the safety concerns, if any, associated with its use. It is the responsibility of the user of this standard to establish appropriate safety, health, and environmental practices and determine the applicability of regulatory limitations prior to use.*

1.5 *This international standard was developed in accordance with internationally recognized principles on standardization established in the Decision on Principles for the Development of International Standards, Guides and Recommendations issued by the World Trade Organization Technical Barriers to Trade (TBT) Committee.*

2. Referenced Documents

2.1 *ASTM Standards*:²

C39/C39M Test Method for Compressive Strength of Cylindrical Concrete Specimens

C1232 Terminology for Masonry

C1552 Practice for Capping Concrete Masonry Units, Related Units and Masonry Prisms for Compression Testing

C1716/C1716M Specification for Compression Testing Ma-

chine Requirements for Concrete Masonry Units, Related Units, and Prisms

3. Terminology

3.1 *Definitions*:

3.1.1 For definitions of terms used in this test method, refer to Terminology C1232.

3.2 *Definitions of Terms Specific to This Standard*:

3.2.1 *bearing rod, n*—steel cylinder to concentrate the applied load along a single line.

3.2.1.1 *Discussion*—The diameter of the bearing rod is determined by the height of the specimen.

3.2.2 *compressible brace, n*—tube or rod made of a non-rigid material.

3.2.2.1 *Discussion*—Compressible braces are used to support the test assembly during the initial loading to prevent the rocking of the test assembly. The compressible braces are required to be the same diameter or slightly smaller in diameter than the bearing rods to prevent interference with the test results.

3.2.3 *gross split length, n*—distance along the fracture from one face of the specimen to the opposite face of the specimen.

3.2.4 *net split length, n*—gross split length minus the length of any voids along the failure plane of the bearing rods.

3.2.5 *test assembly, n*—the combination of the specimen with a bearing rod adhered to the top and a bearing rod adhered to the bottom of the specimen.

4. Summary of Test Method

4.1 A test assembly is made by adhering steel bearing rods to the top and bottom faces of the specimen using capping compound. After the capping compound has cured, the test assembly is placed in the test machine while supported by compressible braces to prevent the test assembly from rocking. A load is applied to the test assembly. The compressible braces are removed once the test machine holds the test assembly firmly. The load is continued to be applied until specimen failure.

5. Significance and Use

5.1 Masonry units alone and within assemblages commonly fail in a tensile mode when loaded in compression to failure.

¹ This test method is under the jurisdiction of ASTM Committee C15 on Manufactured Masonry Units and is the direct responsibility of Subcommittee C15.04 on Research.

Current edition approved July 1, 2020. Published July 2020. Originally approved in 1984. Last previous edition approved in 2020 as C1006 – 20. DOI: 10.1520/C1006_C1006M-20A.

² For referenced ASTM standards, visit the ASTM website, www.astm.org, or contact ASTM Customer Service at service@astm.org. For *Annual Book of ASTM Standards* volume information, refer to the standard's Document Summary page on the ASTM website.

*A Summary of Changes section appears at the end of this standard

These tensile stresses result from differences in modulus of elasticity and Poisson's ratio between the masonry unit and mortar. Additionally, the dissimilarity in behavior of the grout within cores of masonry units under load leads to tensile stresses in the units and results in a splitting failure.

5.2 This test method produces a line load along the bed surface of the masonry unit. The compressive load applied to the unit, imposed by means of bearing rods, results in a tensile stress distributed over the height of the unit for the split length of the unit. This test method can be conducted with the rod oriented either in the longitudinal direction or in the transverse direction of the bed face. The splitting tensile strength is calculated by the equation given in 10.1.

5.3 The test value provides an indicator of masonry-unit splitting tensile strength. Additionally, the presence of defects such as visible voids or impurities in masonry units may be revealed.

5.4 The moisture content of the specimen will affect test results.

5.5 The height of the specimen will affect test results.

6. Apparatus

6.1 *Bearing Rods*—Solid steel bearing rods with diameters 8.0 % to 12.0 % of the specimen height, of a length greater than the gross split length, and of straightness within 0.5 % of the gross split length shall be provided for each unit. The upper and lower bearing rods shall have the same diameters. Bearing rods that meet the straightness requirement can be reused.

6.2 *Compressible Braces*—Non-rigid rods or tubes with a diameter that is 0.0 to 2 mm [0 to 3/32 in.] smaller than the diameter of the bearing rods.

6.3 *Alignment Jig (for specimens less than 100 mm [4.0 in.] high)*—An alignment jig similar to that shown in Figure 1.

NOTE 1—The alignment jig is used while adhering the rods to the specimen to maintain the two bearing rods in the same vertical plane.

6.4 *Supplemental Bearing Bar or Plate*—If the diameter or largest dimension of the upper bearing face or lower bearing block is less than the length of the specimen to be tested, a supplementary bearing bar or plate shall be used. The contact surfaces of the bar or plate shall be machined to within 0.05 % of planeness as measured on any line of contact of the bearing area. The bearing bar or plate shall have a width of at least 50 mm [2.0 in.], and a thickness not less than the distance from the edge of the spherical or rectangular bearing block to the end of the specimen. The bar or plate shall be used in such a manner that the load will be uniformly applied over the entire gross split length.

6.5 *Testing Machine:*

6.5.1 The testing machine shall conform to the requirements of Test Method C39/C39M or Specification C1716/C1716M. The testing machine may be of any type of sufficient capacity that will provide the rate of loading prescribed in 9.3.

6.5.2 The diameter of the bearing surface shall be at least 125 mm [5.0 in.].

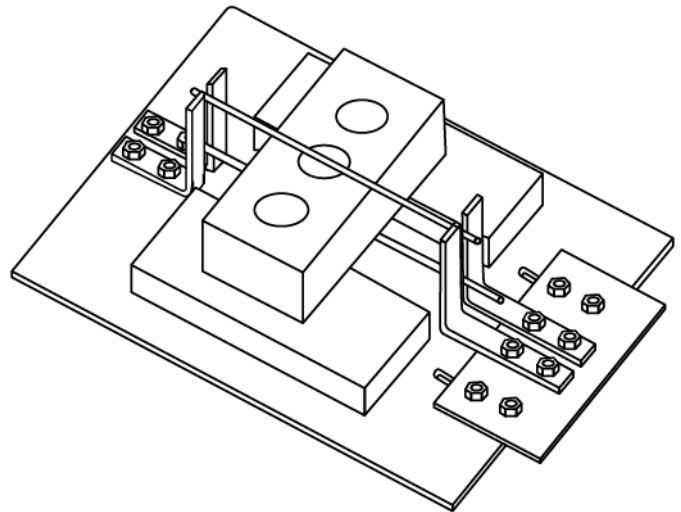

FIG. 1 Example of Alignment Jig for Maintaining Parallel Bearing Rods

7. Materials

7.1 *Capping Material:*

7.1.1 *Gypsum Cement Capping Material*—High-strength gypsum cement capping material meeting the requirements of Practice C1552.

NOTE 2—Suitable high-strength gypsum materials that have been successfully used include Hydro-Stone (trademarked) Gypsum Cement, available from USG (United States Gypsum Company), and Denscal (trademarked) ST Plaster, available from Georgia-Pacific. Other suitable materials may also be available.

8. Sampling

8.1 A test sample shall consist of at least five full-size masonry units. The specimens shall be representative of the whole lot of units from which they are selected. The specimens shall represent the complete range of sizes in the lot.

9. Procedure

9.1 *Positioning Bearing Rods:*

9.1.1 For units less than 100 mm [4.0 in.] high, mark the intended location of the split surface on both faces, stretcher or normally exposed faces for transverse splitting, and end faces for longitudinal splitting. Spread capping compound along the bed surface between these two marks. Place the bearing rod into the fresh compound and press until contact is made with the unit. After the compound has set, place the second bearing rod parallel to the first on the opposite bed surface using the alignment jig (see Fig. 1).

9.1.2 For units with heights of 100 mm [4.0 in.] or greater, use a carpenter's square to draw a line perpendicular to the bed surface on opposite exterior faces. Spread capping compound on the upper bed surfaces between the two lines. Align the bearing rods with the lines on the faces, and press one rod into the fresh compound until in contact with the unit. After the compound has set, invert the unit and repeat this procedure on the opposite bed surface.

9.1.3 The bearing rods shall be positioned no closer to a free edge than one half the specimen height.

9.1.4 The two rods must be within 6 mm in 200 mm [$\frac{1}{4}$ in. in 8 in.] of being parallel.

9.1.5 Cure the capping compound for at least 2 h at $24 \pm 8^\circ\text{C}$ [$75 \pm 15^\circ\text{F}$] prior to testing.

NOTE 3—Alternative methods of applying the line load to the specimen have been used. Wood strips, metal bars of square cross section, and half rounds have been utilized. Such devices, meeting the dimensional requirements of 6.1, are permitted on specimens greater than 100 mm [4.0 in.] in height. The user of any modification should provide comparative data, testing both ways, to validate the alternative method.

9.2 *Test Alignment*—Align the rods with the centerline of the plates, and center the rods in the transverse direction. Support the specimen on compressible braces. Remove the compressible braces when the specimen is held in vertical orientation by the testing-machine platens.

9.3 *Rate of Loading*—Apply the load without impact and load continuously at a rate less than 9000 N/min [2000 lbf/min].

10. Calculations

10.1 Calculate the splitting tensile strength of the specimens as follows:

$$f_t = \frac{2P}{\pi AB_n} \quad (1)$$

where:

- f_t = splitting tensile strength, kPa [psi],
- P = maximum applied load indicated by the testing machine, kN [lb],
- A = split height, mm [in.], and
- B_n = net split length, mm [in.].

11. Report

11.1 The report shall include the following for each masonry unit.

11.1.1 Type and dimensions of specimen,

11.1.2 Identification number,

11.1.3 Gross split length, net split length, and split height mm [in.],

11.1.4 Maximum load in kN [lbf],

11.1.5 Splitting tensile strength calculated to the nearest 50 kPa [5 psi] separately for each specimen and as the average for the set of specimens tested,

11.1.6 Visible voids and impurities in specimen, and

11.1.7 Description of fracture.

12. Precision and Bias

12.1 The laboratory coefficient of variation of test results available is high because of the variability of the material property tested. Coefficients of variation for groups of five specimens ranged from 3 to 40 %, averaging 20 %.

12.1.1 It is expected that the multilaboratory coefficients of variation will be higher than the single operator or single laboratory coefficient of variation.

12.1.2 Tests conducted with rods oriented longitudinally on bed faces normally have higher coefficients of variation than tests conducted with rods oriented transversely.

13. Keywords

13.1 brick; concrete masonry units; masonry; splitting strength; tensile strength

ASTM C1006/C1006M-20a

SUMMARY OF CHANGES

Committee C15 has identified the location of selected changes to this standard since the last issue (C1006/C1006M–20) that may impact the use of this standard. (July 1, 2020)

(1) Changed Section 8.

Committee C15 has identified the location of selected changes to this standard since the last issue (C1006/C1006M–19) that may impact the use of this standard. (January 1, 2020)

(1) Added Test Method C39/C39M and Specification C1716/C1716M to Reference Documents.

(2) Removed Practice E4 from Referenced Documents.

(3) Changed 3.2.2.1, 6.1, 6.2, 6.5.1, 6.5.2, 7.1.1, and 9.1.2.

Committee C15 has identified the location of selected changes to this standard since the last issue (C1006–07(2013)) that may impact the use of this standard. (June 15, 2019)

(1) Added 1.3.

(2) Changed 1.2, 5.2, 6.1 through 6.7, 9.1.1 through 9.3, Figure 1, Equation 1, 11.1 through 11.3.

(3) Added reference to Terminology C1232 and Practice C1552.

(4) Added Note 2, Section 3, Section 4, 5.4, 5.5, 6.2, 6.3, Section 7 and 9.1.4.

(5) Deleted Note 1 and Note 3.